

**ERSATZTEILLISTE  
PARTS LIST  
LISTA DE RECAMBIOS  
LISTE DE PIECE DE  
RECHANGE**



**Art.Nr.:5056136005**

**Weidemann GmbH & Co. KG**

**Weidemann 1360**



**WEIDEMANN**



## Inhaltsverzeichnis

<b>Ersatzteilliste 1360 P33/34/43/45</b> .....	<b>1</b>
<b>Inhaltsverzeichnis 1360</b> .....	<b>10</b>
<b>Filtersatz P33</b> <b>Filter kit P33</b> <b>Trousse de filtres P33</b> <b>Kit de filtro P33</b> .....	<b>12</b>
<b>Filtersatz P34</b> <b>Filter kit P34</b> <b>Trousse de filtres P34</b> <b>Kit de filtro P34</b> .....	<b>14</b>
<b>Filtersatz P43/48</b> <b>Filter kit P43/48</b> <b>Trousse de filtres P43/48</b> <b>Kit de filtro P43/48</b> .....	<b>16</b>
<b>Filtersatz P45</b> <b>Filter kit P45</b> <b>Trousse de filtres P45</b> <b>Kit de filtro P45</b> .....	<b>18</b>
<b>Vorder und Hinterwagen bis 10.2002</b> <b>Car front and rear up to 10-2002</b> <b>Avant et arrière de l'automobile jusqu'à 10-2002</b> <b>Auto, delante y trasera hasta 10-2002</b> .....	<b>20</b>
<b>Vorder und Hinterwagen ab 10.2002</b> <b>Car front and rear from 10-2002 onwards</b> <b>Avant et arrière de l'automobile de 10-2002 et au-delà</b> <b>Auto, delante y trasera desde 10-2002</b> .....	<b>26</b>
<b>Mittelgelenk</b> <b>Central link</b> <b>Lien central</b> <b>Enlace central</b> .....	<b>32</b>
<b>Trittplatte bis 10.2002</b> <b>Step board up to 10-2002</b> <b>Marchepied jusqu'à 10-2002</b> <b>Estribo hasta 10-2002</b> .....	<b>34</b>
<b>Trittplatte ab 10.2002</b> <b>Step board from 10-2002 onwards</b> <b>Marchepied de 10-2002 et au-delà</b> <b>Estribo desde 10-2002</b> .....	<b>38</b>

Sitz MSG 83/S721 Seat MSG 83/S721 Siège MSG 83/S721 Asientos MSG 83/S721 .....	42
<b>Motorhaube</b> Bonnet Bonnet Capó .....	44
Dämmatten Silencing foam Mousse insonorisante Espuma silenciadora .....	48
Ladeschwinge MV (915) Loading rocker MV (915) Culbuteur de chargement MV (915) Brazo de carga MV (915) .....	50
Ladeschwinge HV (920) Loading rocker HV (920) Culbuteur de chargement HV (920) Brazo de carga HV (920) .....	54
Ladeschwinge MV HH (918) Loading rocker MV HH (918) Culbuteur de chargement MV HH (918) Brazo de carga MV HH (918) .....	58
Ladeschwinge HV HH (921) Loading rocker HV HH (921) Culbuteur de chargement HV HH (921) Brazo de carga HV HH (921) .....	62
Motor P33/34 Engine P33/34 Moteur P33/34 Motor P33/34 .....	66
Motor P43 Engine P43 Moteur P43 Motor P43 .....	70
Motor P45 Engine P45 Moteur P45 Motor P45 .....	74

## Inhaltsverzeichnis

Auspuff und Luftfilter P33/34/43/45 bis 10.2002 Exhaust and air filter P33/34/43/45 up to 10.2002 Echappement et filtre à air P33/34/43/45 jusqu'à 01-2001 Escape y filtro de aire P33/34/43/45 hasta 10-2002 .....	78
Auspuff und Luftfilter P33/P34 ab 10.2002 Exhaust and air filter P33/P34 from 10-2002 onwards Echappement et filtre à air P33/P34 de 10-2002 et au-delà Escape y filtro aire P33/P34 desde 10-2002 .....	82
Gasbetätigung und Drehzahlverstellung bis 10.2002 Gas control and RPM setting up to 10-2002 Contrôle de carburant et paramètres tours/min. jusqu'à 10-2002 Ctrol de gas y ajuste RPM hasta 10-2002 .....	86
Gasbetätigung und Drehzahlverstellung ab 10.2002 Gas control and RPM setting from 10-2002 onwards Contrôle de carburant et paramètres tours/min. de 10-2002 et au-delà Ctrol de gas y ajuste RPM desde 10-2002 .....	88
Inchbetätigung Inching operation Operation pas-à-pas Operación de marcha lenta .....	90
Kraftstoffanlage bis 12.2001 Fuel system up to 12-2001 Système de carburant jusqu'à 12-2001 Sistema de combustible hasta 12-2001 .....	92
Kraftstoffanlage ab 12.2001 Fuel system from 12-2001 onwards Système de carburant de 12-2001 et au-delà Sistema de combustible desde 12-2001 .....	96
Elektrische Anlage ohne Beleuchtung I Electrical system without lighting I Système électrique sans éclairage I Sistema eléctrico sin iluminación I .....	100
Elektrische Anlage mit Beleuchtung I Electrical system with lighting I Système électrique avec éclairage I Sistema eléctrico con iluminación I .....	104
Elektrische Anlage mit Beleuchtung II Electrical system with lighting II Système électrique avec éclairage II Sistema eléctrico con iluminación II .....	108



Elektrische Anlage mit Beleuchtung III Electrical system with lighting III Système électrique avec éclairage III Sistema eléctrico con iluminación III.....	112
<b>Armaturenlenksäule starr WDM002 Steering column with instrument panel WDM002 Colonne de direction avec panneau d'instruments WDM002 Columna dirección c/ panel de instrum. WDM002 .....</b>	<b>116</b>
Stromlaufplan starre Lenksäule Wiring diagram right steering column Diagramme de filage colonne de direction droite Diagrama de cableado colum.direcc.derecha .....	122
<b>Armaturenlenksäule verstellbar WDM001 Steering column with instrument panel WDM001 Colonne de direction avec panneau d'instruments WDM001 Columna dirección c/ panel de instrum. WDM001 .....</b>	<b>124</b>
Stromlaufplan verstellbare Lenksäule Wiring diagram adjustable steering column Diagramme de filage colonne de direction ajustable Diagrama de cableado colum.direcc.regul. ....	130
<b>Stromlaufplan Beleuchtung Wiring diagram illumination Diagramme de filage de éclairage Diagrama de cableado iluminación .....</b>	<b>132</b>
Hydraulikschaltplan Hydraulic circuit diagram Diagramme de circuit hydraulique Diagrama de circuito hidráulico.....	134
<b>Ölpumpe Oil pump Pompe à huile Bomba de aceite .....</b>	<b>136</b>
<b>Ölpumpe Oil pump Pompe à huile Bomba de aceite .....</b>	<b>138</b>
<b>Verstellpumpe Displacement pump Pompe de translation Bomba graduable .....</b>	<b>140</b>

Fahrhydraulik P33 bis 10.2002 Drive hydraulics P33 up to 10-2002 Entraînement hydraulique P33 jusqu'à 10-2002 Hidráulica de accionamiento P33 hasta 10-2002.....	142
Fahrhydraulik P33/34 ab 10.2002 Drive hydraulics P33/34 from 10-2002 onwards Entraînement hydraulique P33/34 de 10-2002 et au-delà Hidráulica de accionamiento P33/34 desde 10-2002.....	148
Fahrhydraulik P43 bis 10.2002 Drive hydraulics P43 up to 10-2002 Entraînement hydraulique P43 jusqu'à 10-2002 Hidráulica de accionamiento P43 hasta 10-2002.....	152
Fahrhydraulik P43/45 ab 10.2002 Drive hydraulics P43/45 from 10-2002 onwards Entraînement hydraulique P43/45 de 10-2002 et au-delà Hidráulica de accionamiento P43/45 desde 10-2002.....	156
Lenkhydraulik P33/34 Steering hydraulics P33/34 Système hydraulique de direction P33/34 Hidráulica de dirección P33/34.....	160
Lenkhydraulik P43/45 Steering hydraulics P43/45 Système hydraulique de direction P43/45 Hidráulica de dirección P43/45.....	164
Hydraulikanlage MV Hydraulic system MV Système hydraulique MV Sistema hidráulico MV .....	168
Hydraulikanlage MV HH Hydraulic system MV HH Système hydraulique MV HH Sistema hidráulico MV HH .....	172
Hydraulikanlage HV Hydraulic system HV Système hydraulique HV Sistema hidráulico HV.....	176
Hydraulikanlage HV HH Hydraulic system HV HH Système hydraulique HV HH Sistema hidráulico HV HH .....	180

Kreuzsteuerventil HV 07 Cross control valve HV 07 Valve de croisement de commande HV 07 Válvula de control superior HV 07 .....	184
Kreuzsteuerventil SDS 100 Cross control valve SDS 100 Valve de croisement de commande SDS 100 Válvula de control superior SDS 100 .....	186
Bremsanlage K Achse bis 10.2002 Brake system K Axle up to 10-2002 Système de freinage essieu K jusqu'à 10-2002 Sistema de frenos Eje K hasta 10-2002 .....	188
Bremsanlage K Achse ab 10.2002 Brake system K Axle from 10-2002 onwards Système de freinage essieu K et 10-2002 et au-delà Sistema de frenos Eje K desde 10-2002 .....	192
Bremsanlage S Achse Brake system S Axle Système de freinage essieu S Sistema de frenos Eje S .....	196
Vorderachse K90 bis 09.01 Fg.Nr.:10917446 Front axle K90 up to 09-01 Veh.Nr.10917446 Essieu avant K90 jusqu'à 09-01 Veh.Nr.10917446 Eje frontal K90 hasta 09-01 Veh.Nr.10917446 .....	200
Vorderachse K90 ab 09.01 Fg.Nr.:10917513 Front axle K90 from 09-01 Veh.Nr.10917513 Essieu avant K90 de 09-01 Veh.Nr.10917513 Eje frontal K90 desde 09-01 Veh.Nr.10917513 .....	204
Vorderachse S90 Front axle S90 Essieu avant S90 Eje frontal S90 .....	208
Hinterachse K90 bis 09.01 Fg.Nr.:10917446 Rear axle K90 up to 09-01 Veh.Nr.10917446 Essieu arrière K90 jusqu'à 09-01 Veh.Nr.10917446 Eje trasero K90 hasta 09-01 Veh.Nr.10917446 .....	212
Hinterachse K90 ab 09.01 Fg.Nr.:10917513 Rear axle K90 from 09-01 Veh.Nr.10917513 Essieu arrière K90 de 09-01 Veh.Nr.10917513 Eje trasero K90 desde 09-01 Veh.Nr.10917513 .....	216



Hinterachse S90 Rear axle S90 Essieu arrière S90 Eje trasero S90.....	220
Palettengabel Pallet fork Fourche à palette Horquilla para paletas .....	224
Erdschaufel Earth shovel Pelle à terre Pala de tractor.....	226
Krokodilgebiss Crocodile teeth Dents crocodile Pinzas de cocodrilo.....	228

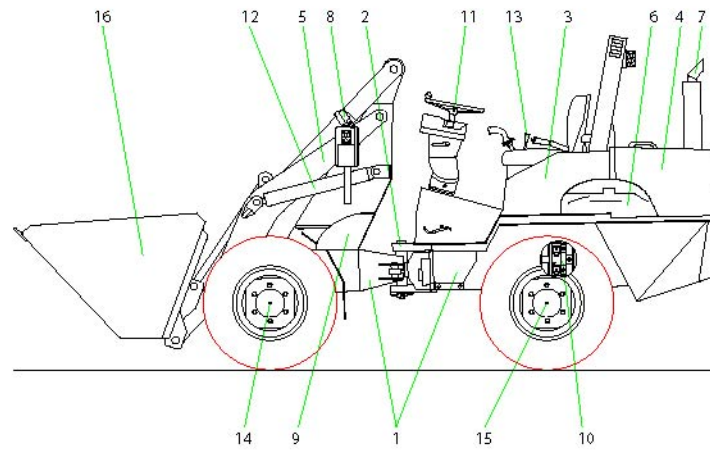

## Inhaltsverzeichnis 1360

Pos.	Bezeichnung
1	Vorder- und Hinterwagen
2	Mittelgelenk
3	Trittplatte
4	Motorhaube
	Dämmatten
5	Schwinge MV 915
	Schwinge HV 920
	Schwinge MV 918 Hohe Hubhöhe
	Schwinge HV 921 Hohe Hubhöhe
6	Motor P33
	Motor P43
7	Auspuff und Luftfilter
	Inchbetätigung
	Drehzahlverstellung und Gasbetätigung
8	Elektrische Anlage I
	Elektrische Anlage II
	Armaturenlenksäule I
	Armaturenlenksäule II

Pos.	Bezeichnung
	Stromlaufplan
9	Kraftstoffanlage
	Verstellpumpe
10	Fahrhydraulik
11	Lenkanlage
12	Hydraulikanlage MV Standard Hubhöhe
	Hydraulikanlage MV
	Hydraulikanlage HV Standard Hubhöhe
	Hydraulikanlage HV
13	Kreuzsteuerventil
14	Vorderachse K90 bis 08.01
	Vorderachse K90 ab 08.01
15	Hinterachse K90 bis 08.01
	Hinterachse K90 ab 08.01
	Bremsanlage
16	Erdschaufel
	Krokodilgebiß
	Palettengabel



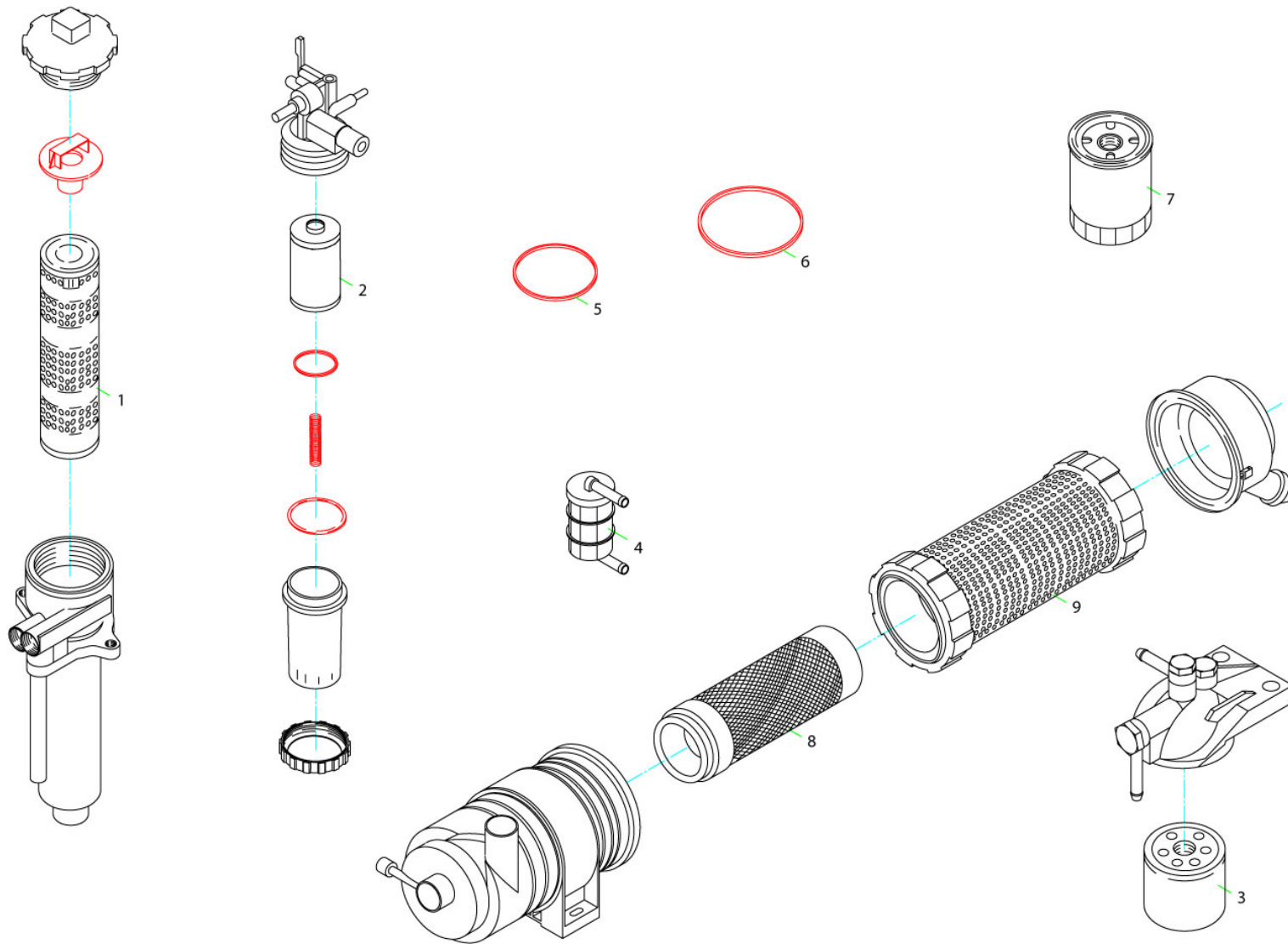

**Filtersatz P33 Filter kit P33 Trousse de filtres P33 Kit de filtro P33**

Pos.	Artikelnr.	Bezeichnung	Description	Pièce de rechange	Parte de repuesto	Menge
	1000231500	Servicesatz	Service kit	Trousse de service	Kit de servicio	1
1	1000231365	Filter	Filter	Filtre	Filtro	1
2	1000159924	Filter	Filter	Filtre	Filtro	1
3	1000199319	Filter	Filter	Filtre	Filtro	1
4	1000199580	Filter	Filter	Filtre	Filtro	1
5	1000199478	Dichtung	Gasket	Garniture	Junta de estanqueidad	1
6	1000199479	Dichtung	Gasket	Garniture	Junta de estanqueidad	1
7	1000231366	Filter	Filter	Filtre	Filtro	1
8	1000231364	Filter	Filter	Filtre	Filtro	1
9	1000231396	Filter	Filter	Filtre	Filtro	1

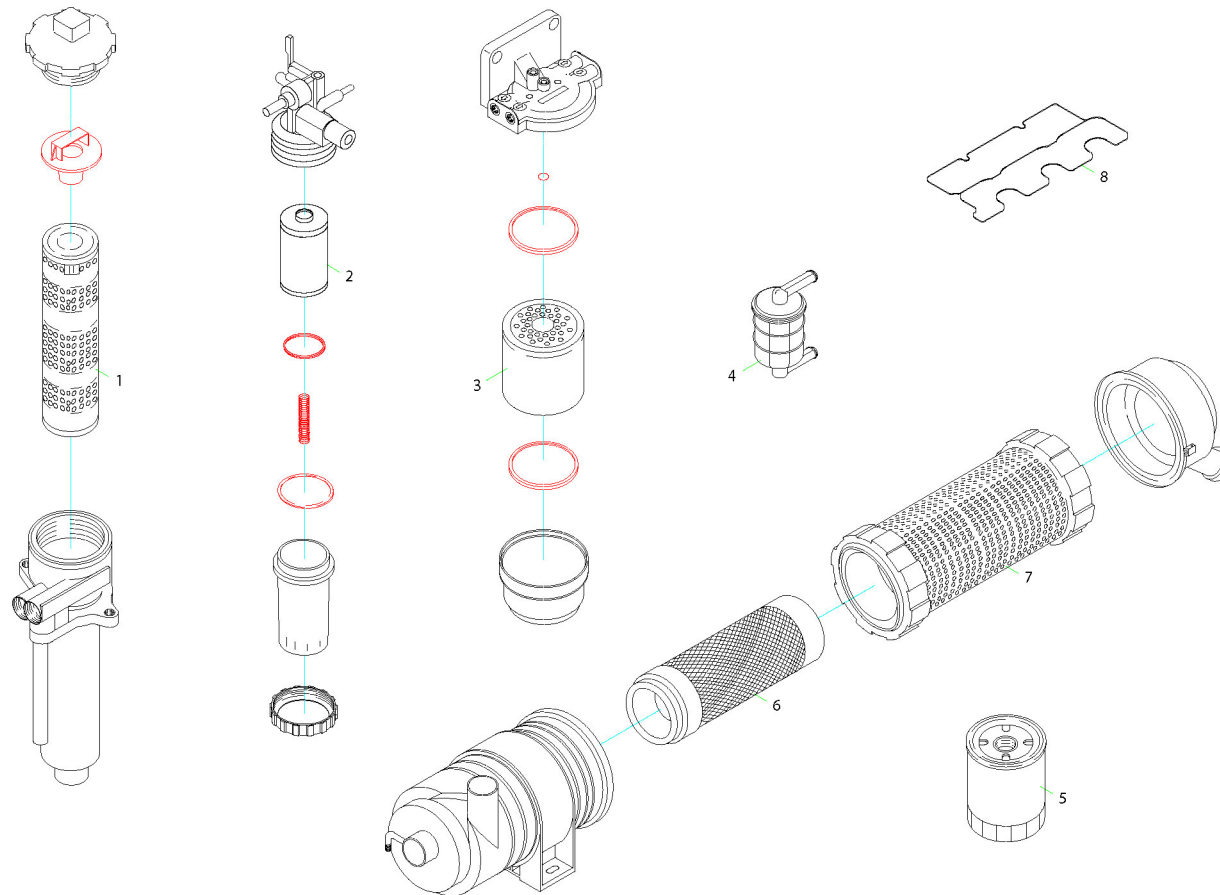

**Filtersatz P34 Filter kit P34 Trousse de filtres P34 Kit de filtro P34**

Pos.	Artikelnr.	Bezeichnung	Description	Pièce de rechange	Parte de repuesto	Menge
	1000231450	Servicesatz	Service kit	Trousse de service	Kit de servicio	1,00
1	1000231365	Filter	Filter	Filtre	Filtro	1,00
2	1000159924	Filter	Filter	Filtre	Filtro	1,00
3	1000197229	Filter	Filter	Filtre	Filtro	1,00
4	1000199580	Filter	Filter	Filtre	Filtro	1,00
5	1000231366	Filter	Filter	Filtre	Filtro	1,00
6	1000231364	Filter	Filter	Filtre	Filtro	1,00
7	1000231396	Filter	Filter	Filtre	Filtro	1,00
8	1000206003	Dichtung	Gasket	Garniture	Junta de estanqueidad	1,00

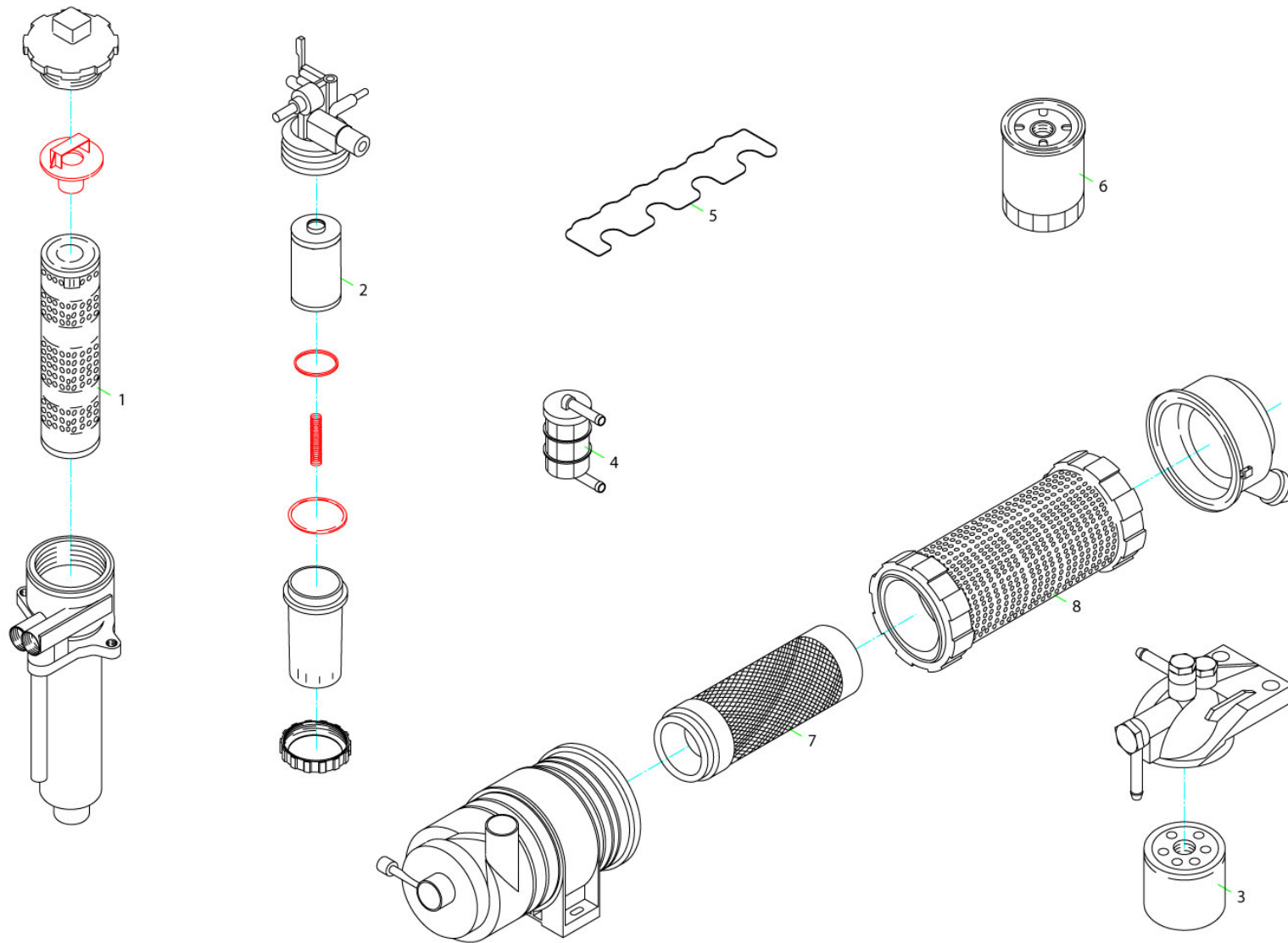



**Filtersatz P43/48 Filter kit P43/48 Trousse de filtres P43/48 Kit de filtro P43/48**

Pos.	Artikelnr.	Bezeichnung	Description	Pièce de rechange	Parte de repuesto	Menge
	1000231451	Servicesatz	Service kit	Trousse de service	Kit de servicio	1
1	1000231365	Filter	Filter	Filtre	Filtro	1
2	1000159924	Filter	Filter	Filtre	Filtro	1
3	1000199319	Filter	Filter	Filtre	Filtro	1
4	1000199580	Filter	Filter	Filtre	Filtro	1
5	1000199481	Dichtung	Gasket	Garniture	Junta de estanqueidad	1
6	1000231366	Filter	Filter	Filtre	Filtro	1
7	1000231364	Filter	Filter	Filtre	Filtro	1
8	1000231396	Filter	Filter	Filtre	Filtro	1

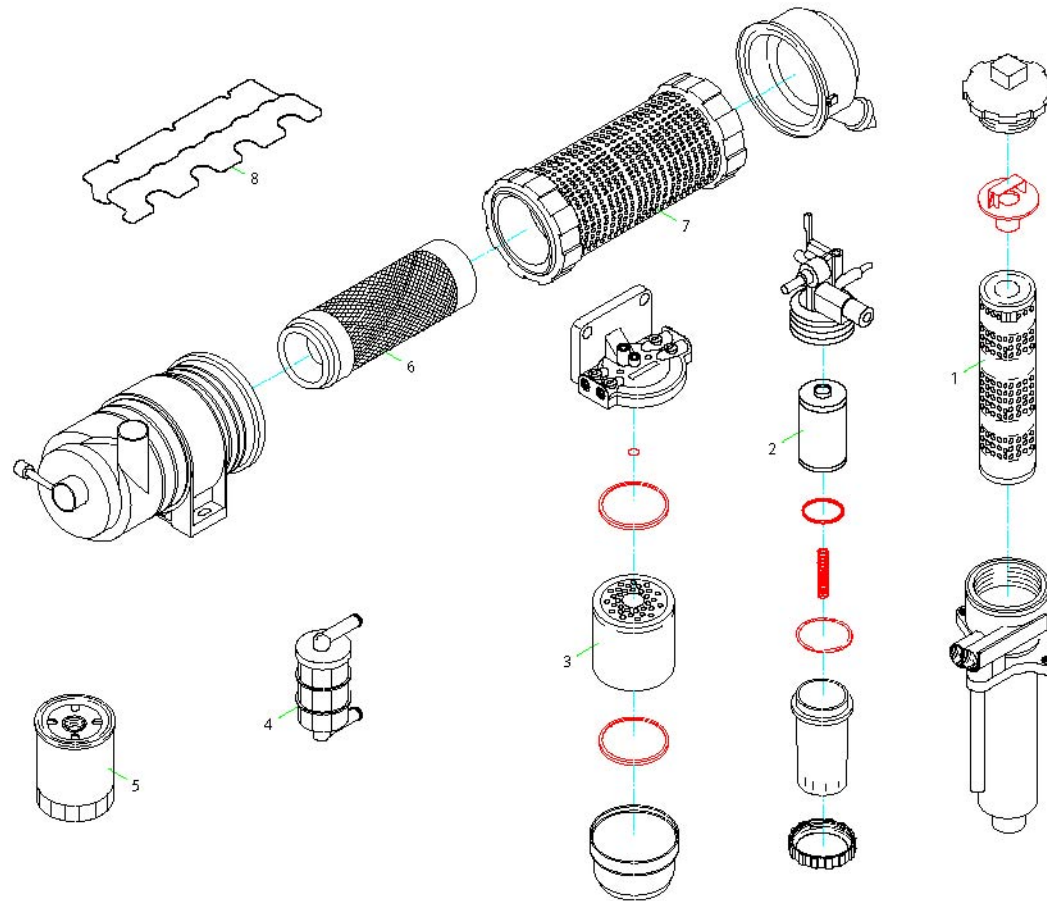

**Filtersatz P45 Filter kit P45 Trousse de filtres P45 Kit de filtro P45**

Pos.	Artikelnr.	Bezeichnung	Description	Pièce de rechange	Parte de repuesto	Menge
	1000231435	Servicesatz	Service kit	Trousse de service	Kit de servicio	1,00
1	1000231365	Filter	Filter	Filtre	Filtro	1,00
2	1000159924	Filter	Filter	Filtre	Filtro	1,00
3	1000197229	Filter	Filter	Filtre	Filtro	1,00
4	1000199580	Filter	Filter	Filtre	Filtro	1,00
5	1000231366	Filter	Filter	Filtre	Filtro	1,00
6	1000231364	Filter	Filter	Filtre	Filtro	1,00
7	1000231396	Filter	Filter	Filtre	Filtro	1,00
8	1000203390	Dichtung	Gasket	Garniture	Junta de estanqueidad	1,00

Vorder und Hinterwagen bis 10.2002 Car front and rear up to 10-2002 Avant et arrière de l'automobile jusqu'à 10-2002 Auto, devant. y trasera hasta 10-2002

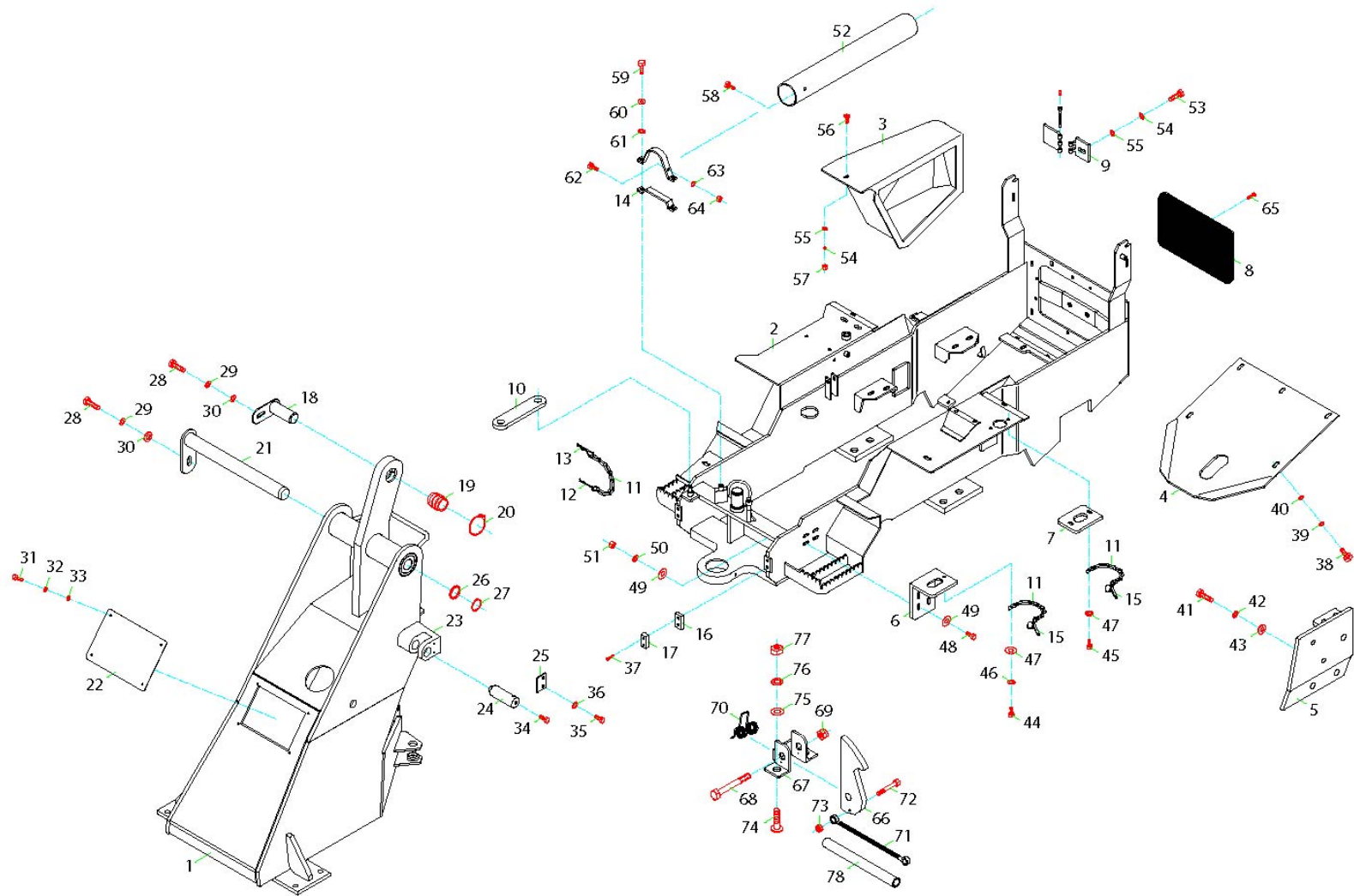

**Vorder und Hinterwagen bis 10.2002 Car front and rear up to 10-2002 Avant et arrière de l'automobile jusqu'à 10-2002 Auto, delante. y trasera hasta 10-2002**

Pos.	Artikelnr.	Bezeichnung	Description	Pièce de rechange	Parte de repuesto	Menge
1	1000202285	Vorderwagen	Front carriage	Chariot de tête	Carro delantero	1
2	1000201990	Hinterwagen	Rear carriage	Chariot arrière	Carro trasero	1
3	1000202205	Abdeckung	Cover	Couvercle	Cubierta	1
4	1000202180	Bodenblech	Bottom liner	Garniture inférieure	Recubrimiento de fondo	1
5	1000202216	Halterung	Bracket	Équerre	Soporte	1
6	1000202232	Arretierung	Locking device	Dispositif de verrouillage	Dispositivo de bloqueo	1
7	1000202670	Halterung	Bracket	Équerre	Soporte	1
8	1000202181	Gitter	Grid	Grille	Rejilla	1
9	1000222579	Scharnier	Hinge	Charnière	Bisagra	1
10	1000201903	Transportsicherung	Transport securing strip	Bande de fixation pour transport	Banda de sujeción transporte	1
11	1000082730	Sicherung	Retainer	Dispositif de retenue	Retén	1
12	1000015456	Splint	Cotter pin	Goupille fendue	Pasador de chaveta	1
13	1000002967	Federstecker	Hairpin spring	Ressort à arc	Resorte en V	1
14	1000201888	Halterung	Bracket	Équerre	Soporte	1
15	1000222562	Sicherung	Retainer	Dispositif de retenue	Retén	1
16	1000200408	Distanzstück	Spacer	Ecarteur	Espaciador	1
17	1000228616	Gummipuffer	Silent block	Silentbloc	Bloque silente	1
18	1000224743	Bolzen	Bolt	Boulon	Perno	1
19	1000224830	Lager	Bearing	Palier	Cojinete	1
20	1000015465	Ring	Ring	Anneau	Anillo	1
21	1000224758	Bolzen	Bolt	Boulon	Perno	1
22	1000200397	Abdeckblech	Cover plate	Panneau de couvercle	Placa de cubierta	1
23	1000228760	Klaue	Claw	Griffe	Garra	1
24	1000224248	Bolzen	Bolt	Boulon	Perno	1

Vorder und Hinterwagen bis 10.2002 Car front and rear up to 10-2002 Avant et arrière de l'automobile jusqu'à 10-2002 Auto, delante y trasera hasta 10-2002

Pos.	Artikelnr.	Bezeichnung	Description	Pièce de rechange	Parte de repuesto	Menge
25	1000194577	Platte	Plate	Plaque	Placa	1
26	1000094768	Scheibe	Washer	Rondelle	Disco	1
27	1000095360	Ring	Ring	Anneau	Anillo	1
28	1000085411	Schraube	Bolt	Boulon	Perno	1
29	1000022016	Federring	Spring washer	Rondelle de ressort	Arandela de resorte	1
30	1000015432	Scheibe	Washer	Rondelle	Disco	1
31	1000018400	Schraube	Bolt	Boulon	Perno	1
32	1000015444	Federring	Spring washer	Rondelle de ressort	Arandela de resorte	1
33	1000015430	Scheibe	Washer	Rondelle	Disco	1
34	1000015345	Schraube	Bolt	Boulon	Perno	1
35	1000015343	Schraube	Bolt	Boulon	Perno	1
36	1000222819	Scheibe	Washer	Rondelle	Disco	1
37	1000128080	Schraube	Bolt	Boulon	Perno	1
38	1000015345	Schraube	Bolt	Boulon	Perno	1
39	1000022016	Federring	Spring washer	Rondelle de ressort	Arandela de resorte	1
40	1000222577	Scheibe	Washer	Rondelle	Disco	1
41	1000019136	Schraube	Bolt	Boulon	Perno	1
42	1000082617	Federring	Spring washer	Rondelle de ressort	Arandela de resorte	1
43	1000222552	Scheibe	Washer	Rondelle	Disco	1
44	1000018400	Schraube	Bolt	Boulon	Perno	1
45	1000085384	Schraube	Bolt	Boulon	Perno	1
46	1000015444	Federring	Spring washer	Rondelle de ressort	Arandela de resorte	1
47	1000222992	Scheibe	Washer	Rondelle	Disco	1
48	1000223203	Schraube	Bolt	Boulon	Perno	1
49	1000222577	Scheibe	Washer	Rondelle	Disco	1

Vorder und Hinterwagen bis 10.2002 Car front and rear up to 10-2002 Avant et arrière de l'automobile jusqu'à 10-2002 Auto, delante y trasera hasta 10-2002

Pos.	Artikelnr.	Bezeichnung	Description	Pièce de rechange	Parte de repuesto	Menge
50	1000022016	Federring	Spring washer	Rondelle de ressort	Arandela de resorte	1
51	1000015407	Mutter	Nut	Écrou	Tuerca	1
52	1000216866	Schlauch	Hose	Boyau	Manguera	1
53	1000015346	Schraube	Bolt	Boulon	Perno	1
54	1000022016	Federring	Spring washer	Rondelle de ressort	Arandela de resorte	1
55	1000222577	Scheibe	Washer	Rondelle	Disco	1
56	1000048576	Schraube	Bolt	Boulon	Perno	1
57	1000015407	Mutter	Nut	Écrou	Tuerca	1
58	1000048572	Schraube	Bolt	Boulon	Perno	1
59	1000079385	Schraube	Bolt	Boulon	Perno	1
60	1000082617	Federring	Spring washer	Rondelle de ressort	Arandela de resorte	1
61	1000222819	Scheibe	Washer	Rondelle	Disco	1
62	1000015343	Schraube	Bolt	Boulon	Perno	1
63	1000222819	Scheibe	Washer	Rondelle	Disco	1
64	1000015406	Mutter	Nut	Écrou	Tuerca	1
65	1000223979	Schraube	Bolt	Boulon	Perno	1
66	1000202663	Arretierung	Locking device	Dispositif de verrouillage	Dispositivo de bloqueo	1
67	1000202664	Halterung	Bracket	Équerre	Soporte	1
68	1000082517	Schraube	Bolt	Boulon	Perno	1
69	1000020788	Mutter	Nut	Écrou	Tuerca	1
70	1000223656	Feder	Spring	Ressort	Resorte	1
71	1000222700	Seil	Rope	Corde	Soga	1
72	1000015339	Schraube	Bolt	Boulon	Perno	1
73	1000085588	Mutter	Nut	Écrou	Tuerca	1
74	1000222474	Schraube	Bolt	Boulon	Perno	1

Vorder und Hinterwagen bis 10.2002 Car front and rear up to 10-2002 Avant et arrière de l'automobile jusqu'à 10-2002 Auto, delante y trasera hasta 10-2002

Pos.	Artikelnr.	Bezeichnung	Description	Pièce de rechange	Parte de repuesto	Menge
75	1000223005	Scheibe	Washer	Rondelle	Disco	1
76	1000022017	Federring	Spring washer	Rondelle de ressort	Arandela de resorte	1
77	1000049000	Mutter	Nut	Écrou	Tuerca	1
78	1000221616	Schlauch	Hose	Boyau	Manguera	1





**WEIDEMANN**

**Weidemann 1360**

Vorder und Hinterwagen ab 10.2002 Car front and rear from 10-2002 onwards Avant et arrière de l'automobile de 10-2002 et au-delà Auto, devant. y trasera desde 10-2002

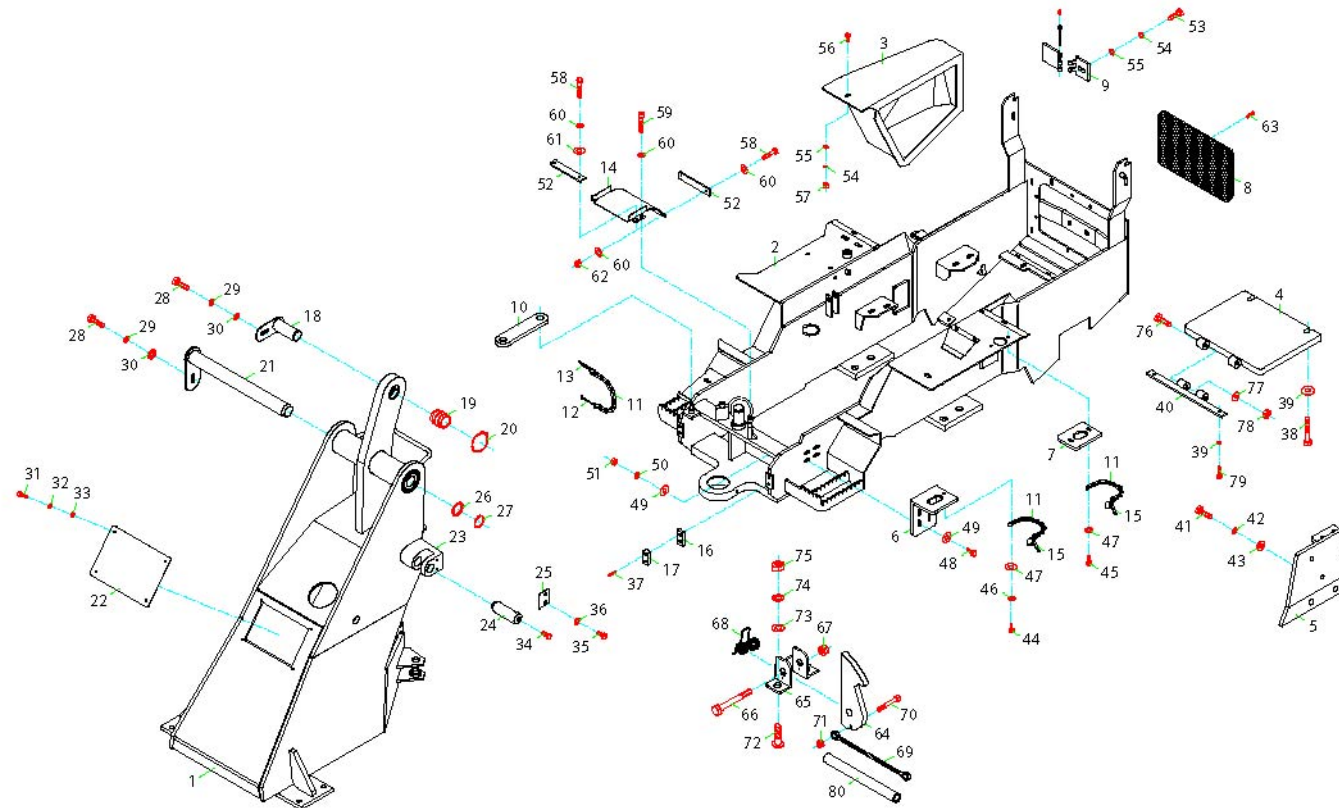

**Vorder und Hinterwagen ab 10.2002 Car front and rear from 10-2002 onwards Avant et arrière de l'automobile de 10-2002 et au-delà Auto, delante. y trasera desde 10-2002**

Pos.	Artikelnr.	Bezeichnung	Description	Pièce de rechange	Parte de repuesto	Menge
1	1000203950	Vorderwagen	Front carriage	Chariot de tête	Carro delantero	1,00
2	1000205706	Hinterwagen	Rear carriage	Chariot arrière	Carro trasero	1,00
3	1000202205	Abdeckung	Cover	Couvercle	Cubierta	1,00
4	1000202180	Bodenblech	Bottom liner	Garniture inférieure	Recubrimiento de fondo	1,00
5	1000204609	Halterung	Bracket	Équerre	Soporte	1,00
6	1000204573	Arretierung	Cover	Cover	Cover	1,00
7	1000202670	Halterung	Locking device	Couvercle	Cubierta	1,00
8	1000202181	Gitter	Grid	Grille	Rejilla	1,00
9	1000222579	Scharnier	Hinge	Charnière	Bisagra	1,00
10	1000201903	Transportsicherung	Transport securing strip	Bande de fixation pour transport	Banda de sujeción transporte	1,00
11	1000082730	Sicherung	Retainer	Dispositif de retenue	Retén	1,00
12	1000015456	Splint	Cotter pin	Goupille fendue	Pasador de chaveta	1,00
13	1000082627	Federstecker	Hairpin spring	Ressort à arc	Resorte en V	1,00
14	1000205119	Halterung	Bracket	Équerre	Soporte	1,00
15	1000050587	Klappstecker	Locking pin	Goupille de verrouillage	Clavija de bloqueo	1,00
16	1000200408	Distanzstück	Spacer	Ecarteur	Espaciador	1,00
17	1000228616	Gummipuffer	Silent block	Silentbloc	Bloque silente	2,00
18	1000224743	Bolzen	Bolt	Boulon	Perno	1,00
19	1000224830	Lager	Bearing	Palier	Cojinete	1,00
20	1000015465	Ring	Ring	Anneau	Anillo	1,00
21	1000224758	Bolzen	Bolt	Boulon	Perno	1,00
22	1000200397	Abdeckblech	Cover plate	Panneau de couvercle	Placa de cubierta	1,00
23	1000228760	Klaue	Claw	Griffe	Garra	2,00
24	1000224248	Bolzen	Bolt	Boulon	Perno	2,00

Vorder und Hinterwagen ab 10.2002 Car front and rear from 10-2002 onwards Avant et arrière de l'automobile de 10-2002 et au-delà Auto, devant. y trasera desde 10-2002

Pos.	Artikelnr.	Bezeichnung	Description	Pièce de rechange	Parte de repuesto	Menge
25	1000194577	Platte	Plate	Plaque	Placa	1,00
26	1000094768	Scheibe	Washer	Rondelle	Disco	1,00
27	1000095360	Ring	Ring	Anneau	Anillo	1,00
28	1000223198	Schraube	Bolt	Boulon	Perno	1,00
29	1000022016	Federring	Spring washer	Rondelle de ressort	Arandela de resorte	1,00
30	1000222577	Scheibe	Washer	Rondelle	Disco	1,00
31	1000018400	Schraube	Bolt	Boulon	Perno	4,00
32	1000015444	Federring	Spring washer	Rondelle de ressort	Arandela de resorte	4,00
33	1000015430	Scheibe	Washer	Rondelle	Disco	4,00
34	1000015345	Schraube	Bolt	Boulon	Perno	1,00
35	1000015342	Schraube	Bolt	Boulon	Perno	1,00
36	1000082617	Federring	Spring washer	Rondelle de ressort	Arandela de resorte	1,00
37	1000128080	Schraube	Bolt	Boulon	Perno	2,00
38	1000047391	Schraube	Bolt	Boulon	Perno	2,00
39	1000015433	Scheibe	Washer	Rondelle	Disco	2,00
40	1000206246	Halterung	Bracket	Équerre	Soporte	1,00
41	1000019136	Schraube	Bolt	Boulon	Perno	2,00
42	1000082617	Federring	Spring washer	Rondelle de ressort	Arandela de resorte	2,00
43	1000222552	Scheibe	Washer	Rondelle	Disco	2,00
44	1000018400	Schraube	Bolt	Boulon	Perno	1,00
45	1000085384	Schraube	Bolt	Boulon	Perno	1,00
46	1000015444	Federring	Spring washer	Rondelle de ressort	Arandela de resorte	1,00
47	1000222992	Scheibe	Washer	Rondelle	Disco	1,00
48	1000223203	Schraube	Bolt	Boulon	Perno	1,00
49	1000222577	Scheibe	Washer	Rondelle	Disco	1,00

Vorder und Hinterwagen ab 10.2002 Car front and rear from 10-2002 onwards Avant et arrière de l'automobile de 10-2002 et au-delà Auto, devant. y trasera desde 10-2002

Pos.	Artikelnr.	Bezeichnung	Description	Pièce de rechange	Parte de repuesto	Menge
50	1000022016	Federring	Spring washer	Rondelle de ressort	Arandela de resorte	1,00
51	1000015407	Mutter	Nut	Écrou	Tuerca	1,00
52	1000205119	Halterung	Bracket	Équerre	Soporte	2,00
53	1000015346	Schraube	Bolt	Boulon	Perno	1,00
54	1000022016	Federring	Spring washer	Rondelle de ressort	Arandela de resorte	1,00
55	1000222577	Scheibe	Washer	Rondelle	Disco	1,00
56	1000048576	Schraube	Bolt	Boulon	Perno	1,00
57	1000015407	Mutter	Nut	Écrou	Tuerca	1,00
58	1000085318	Schraube	Bolt	Boulon	Perno	2,00
59	1000015370	Schraube	Bolt	Boulon	Perno	2,00
60	1000082617	Federring	Spring washer	Rondelle de ressort	Arandela de resorte	2,00
61	1000222819	Scheibe	Washer	Rondelle	Disco	4,00
62	1000015412	Mutter	Nut	Écrou	Tuerca	2,00
63	1000223979	Schraube	Bolt	Boulon	Perno	4,00
64	1000202663	Haken	Hook	Crochet	Gancho	1,00
65	1000202664	Rahmen	Frame	Châssis	Bastidor	1,00
66	1000223594	Schraube	Bolt	Boulon	Perno	1,00
67	1000020788	Mutter	Nut	Écrou	Tuerca	1,00
68	1000223656	Feder	Spring	Ressort	Resorte	1,00
69	1000222700	Seil	Rope	Corde	Soga	1,00
70	1000015339	Schraube	Bolt	Boulon	Perno	1,00
71	1000085588	Mutter	Nut	Écrou	Tuerca	1,00
72	1000222474	Schraube	Bolt	Boulon	Perno	2,00
73	1000223005	Scheibe	Washer	Rondelle	Disco	2,00
74	1000022017	Federring	Spring washer	Rondelle de ressort	Arandela de resorte	2,00

Vorder und Hinterwagen ab 10.2002 Car front and rear from 10-2002 onwards Avant et arrière de l'automobile de 10-2002 et au-delà Auto, delante. y trasera desde 10-2002

Pos.	Artikelnr.	Bezeichnung	Description	Pièce de rechange	Parte de repuesto	Menge
75	1000049000	Mutter	Nut	Écrou	Tuerca	2,00
76	1000048216	Schraube	Bolt	Boulon	Perno	2,00
77	1000085605	Scheibe	Washer	Rondelle	Disco	2,00
78	1000020788	Mutter	Nut	Écrou	Tuerca	2,00
79	1000085418	Schraube	Bolt	Boulon	Perno	2,00
80	1000221616	Schlauch	Hose	Boyau	Manguera	1,00



**WEIDEMANN**

**Weidemann 1360**

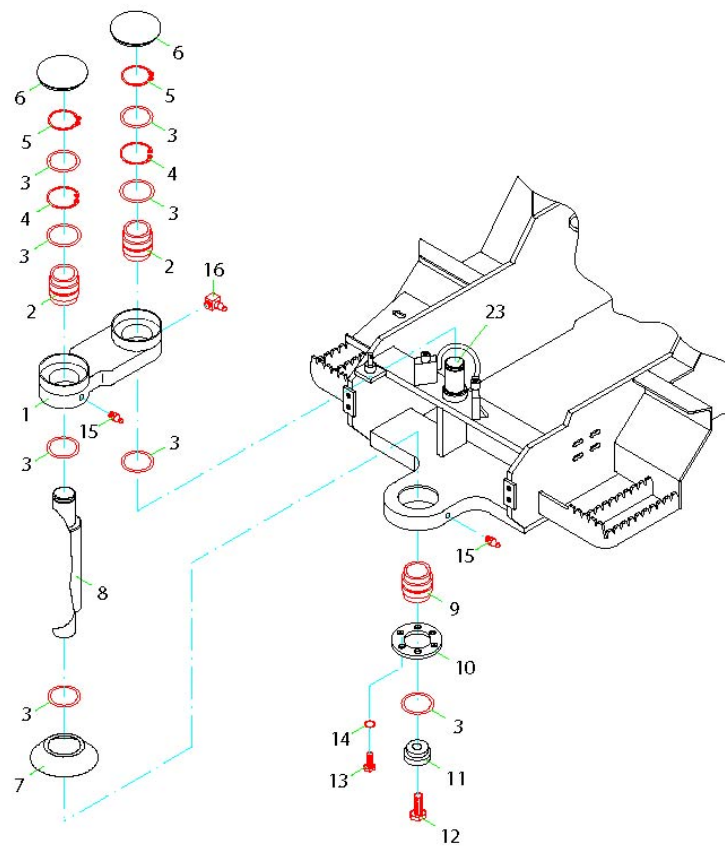



Mittelgelenk Central link Lien central Enlace central

Pos.	Artikelnr.	Bezeichnung	Description	Pièce de rechange	Parte de repuesto	Menge
1	1000208952	Gehäuse	Housing	Enveloppe	Carcasa	1
2	1000224250	Lager	Bearing	Palier	Cojinete	1
3	1000095347	Scheibe	Washer	Rondelle	Disco	1
	1000192755	Ausgleichscheibensatz	Set of washers	Jeu de rondelles	Juego de arandelas	1
4	1000013035	Ring	Ring	Anneau	Anillo	1
5	1000082755	Ring	Ring	Anneau	Anillo	1
6	1000192905	Stopfen	Plug	Prise	Enchufe	1
7	1000228755	Scheibe	Washer	Rondelle	Disco	1
8	1000200404	Welle	Shaft	Arbre	Árbol	1
9	1000224321	Lager	Bearing	Palier	Cojinete	1
10	1000195212	Scheibe	Washer	Rondelle	Disco	1
11	1000196292	Scheibe	Washer	Rondelle	Disco	1
12	1000222885	Schraube	Bolt	Boulon	Perno	1
13	1000015345	Schraube	Bolt	Boulon	Perno	1
14	1000022016	Federring	Spring washer	Rondelle de ressort	Arandela de resorte	1
15	1000222726	Schmiernippel	Grease nipple	Raccord graisseur	Boquilla de engrasar	1
16	1000223032	Schmiernippel	Grease nipple	Raccord graisseur	Boquilla de engrasar	1
23	1000225020	Bolzen	Bolt	Boulon	Perno	1

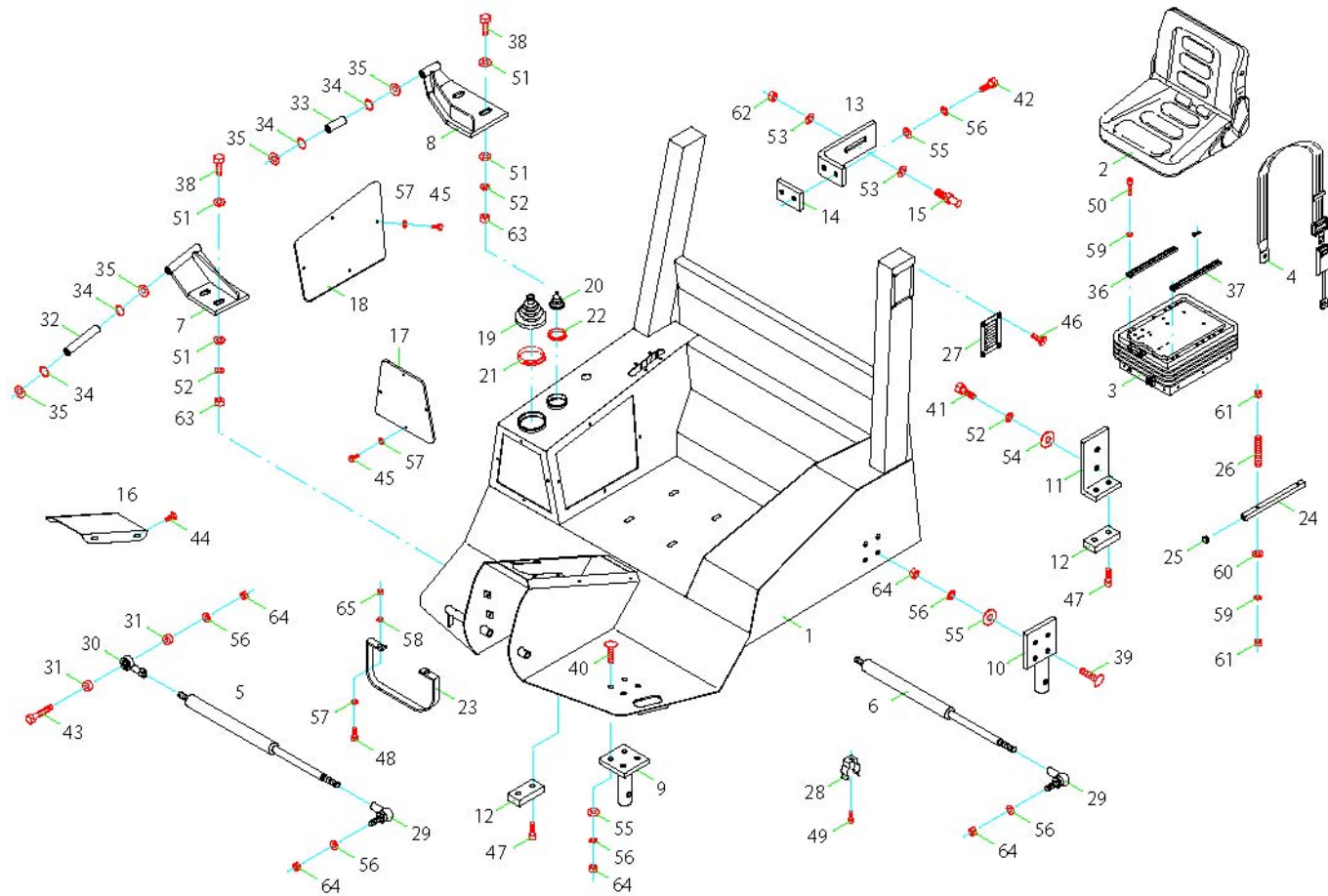

Trittplatte bis 10.2002 Step board up to 10-2002 Marchepied jusqu'à 10-2002 Estribo hasta 10-2002

Pos.	Artikelnr.	Bezeichnung	Description	Pièce de rechange	Parte de repuesto	Menge	Ausführung:
1	1000202220	Trittplatte	Step board	Marchepied	Estribo	1	bis 10.2001
	1000204270	Trittplatte	Step board	Marchepied	Estribo	1	ab 11.2001
2	1000197248	Sitz	Seat	Siège	Asiento	1	
3	1000197246	Federung	Suspension	Suspension	Suspensión	1	
4	1000128034	Sicherheitsgurt	Safety belt	Ceinture de sécurité	Cinturón de seguridad	1	
5	1000224190	Feder	Spring	Ressort	Resorte	1	
6	1000200710	Stange	Rod	Tige	Varilla	1	
7	1000202667	Kippvorrichtung	Tipping device	Dispositif de bascule	Dispositivo de inclinación	1	
8	1000225671	Kippvorrichtung	Tipping device	Dispositif de bascule	Dispositivo de inclinación	1	
9	1000224667	Bolzen	Bolt	Boulon	Perno	1	
10	1000225671	Bolzen	Bolt	Boulon	Perno	1	
11	1000202671	Halter	Bracket	Équerre	Soporte	1	
12	1000228616	Gummipuffer	Silent block	Silentbloc	Bloque silente	1	
13	1000202251	Halterung	Bracket	Équerre	Soporte	1	
14	1000202669	Gewindeplatte	Mounting plate	Plaque d'installation	Placa de montaje	1	
15	1000225389	Bolzen	Bolt	Boulon	Perno	1	
16	1000202249	Abdeckblech	Cover plate	Panneau de couvercle	Placa de cubierta	1	
17	1000202248	Abdeckblech	Cover plate	Panneau de couvercle	Placa de cubierta	1	
18	1000202246	Abdeckblech	Cover plate	Panneau de couvercle	Placa de cubierta	1	
19	1000228617	Faltenbalg	Bellows	Soufflet	Fuelle	1	
20	1000228634	Faltenbalg	Bellows	Soufflet	Fuelle	1	
21	1000223550	Schelle	Clamp	Attache	Abrazadera	1	
22	1000223548	Schelle	Clamp	Attache	Abrazadera	1	
23	1000202221	Halterung	Bracket	Équerre	Soporte	1	

Trittplatte bis 10.2002 Step board up to 10-2002 Marchepied jusqu'à 10-2002 Estribo hasta 10-2002

Pos.	Artikelnr.	Bezeichnung	Description	Pièce de rechange	Parte de repuesto	Menge	Ausführung:
24	1000197246	Federung	Suspension	Suspension	Suspensión	1	
25	1000192898	Stopfen	Plug	Prise	Enchufe	1	
26	1000222706	Schraube	Bolt	Boulon	Perno	1	
27	1000200194	Gitter	Grid	Grille	Rejilla	1	
28	1000222601	Feder	Spring	Ressort	Resorte	1	
29	1000249903	Kugelgelenk	Ball joint	Joint sphérique	Junta de bola	1	
30	1000222688	Gelenkkopf	Swivel head	Tête à rotule	Cabezal giratorio	1	
31	1000224183	Hülse	Sleeve	Manchon	Manguito	1	
32	1000225521	Bolzen	Bolt	Boulon	Perno	1	
33	1000225521	Bolzen	Bolt	Boulon	Perno	1	
34	1000095351	Scheibe	Washer	Rondelle	Disco	1	
35	1000095358	Ring	Ring	Anneau	Anillo	1	
36	1000197234	Schiene	Rail	Rail	Riel	1	
37	1000035621	Schiene	Rail	Rail	Riel	1	
38	1000085419	Schraube	Bolt	Boulon	Perno	1	
39	1000223203	Schraube	Bolt	Boulon	Perno	1	
40	1000048576	Schraube	Bolt	Boulon	Perno	1	
41	1000015347	Schraube	Bolt	Boulon	Perno	1	
42	1000015364	Schraube	Bolt	Boulon	Perno	1	
43	1000085414	Schraube	Bolt	Boulon	Perno	1	
44	1000222572	Schraube	Bolt	Boulon	Perno	1	
45	1000082237	Schraube	Bolt	Boulon	Perno	1	
46	1000224009	Schraube	Bolt	Boulon	Perno	1	
47	1000085493	Schraube	Bolt	Boulon	Perno	1	
48	1000085384	Schraube	Bolt	Boulon	Perno	1	

Trittplatte bis 10.2002 Step board up to 10-2002 Marchepied jusqu'à 10-2002 Estribo hasta 10-2002

Pos.	Artikelnr.	Bezeichnung	Description	Pièce de rechange	Parte de repuesto	Menge	Ausführung:
49	1000022386	Schraube	Bolt	Boulon	Perno	1	
50	1000019593	Schraube	Bolt	Boulon	Perno	1	
51	1000223005	Scheibe	Washer	Rondelle	Disco	1	
52	1000022017	Federring	Spring washer	Rondelle de ressort	Arandela de resorte	1	
53	1000015433	Scheibe	Washer	Rondelle	Disco	1	
54	1000222774	Scheibe	Washer	Rondelle	Disco	1	
55	1000222577	Scheibe	Washer	Rondelle	Disco	1	
56	1000022016	Federring	Spring washer	Rondelle de ressort	Arandela de resorte	1	
57	1000015430	Scheibe	Washer	Rondelle	Disco	1	
58	1000015444	Federring	Spring washer	Rondelle de ressort	Arandela de resorte	1	
59	1000082617	Federring	Spring washer	Rondelle de ressort	Arandela de resorte	1	
60	1000222819	Scheibe	Washer	Rondelle	Disco	1	
61	1000015406	Mutter	Nut	Écrou	Tuerca	1	
62	1000170695	Mutter	Nut	Écrou	Tuerca	1	
63	1000049000	Mutter	Nut	Écrou	Tuerca	1	
64	1000015407	Mutter	Nut	Écrou	Tuerca	1	
65	1000085588	Mutter	Nut	Écrou	Tuerca	1	

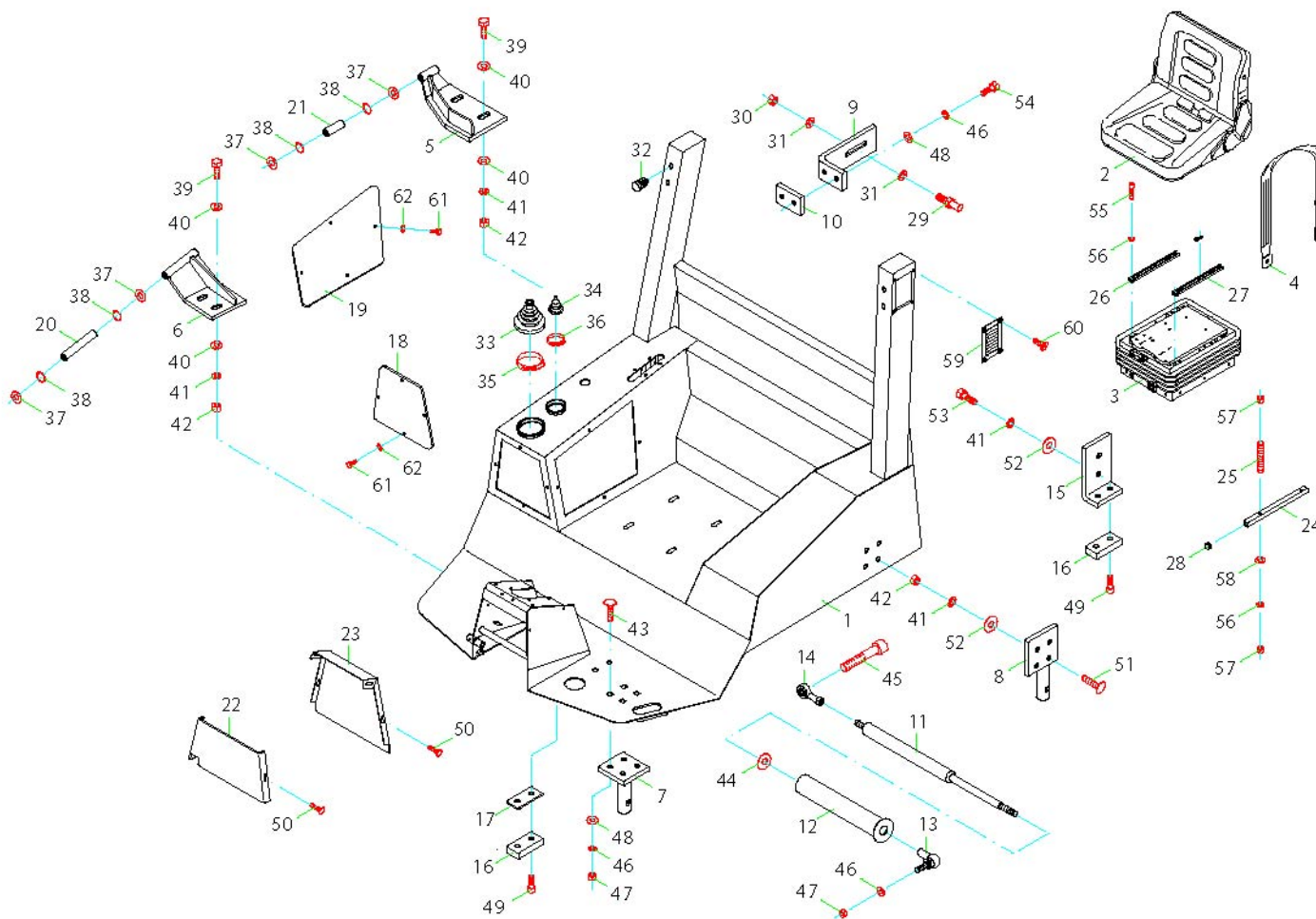

Trittplatte ab 10.2002 Step board from 10-2002 onwards Marchepied de 10-2002 et au-delà Estribo desde 10-2002

Pos.	Artikelnr.	Bezeichnung	Description	Pièce de rechange	Parte de repuesto	Menge
1	1000205495	Trittplatte	Step board	Marchepied	Estribo	1,00
2	1000197244	Sitz	Seat	Siège	Asiento	1,00
3	1000197246	Federung	Suspension	Suspension	Suspensión	1,00
4	1000128034	Sicherheitsgurt	Safety belt	Ceinture de sécurité	Cinturón de seguridad	1,00
5	1000202668	Kippvorrichtung	Tipping device	Dispositif de bascule	Dispositivo de inclinación	1,00
6	1000202667	Kippvorrichtung	Tipping device	Dispositif de bascule	Dispositivo de inclinación	1,00
7	1000224667	Bolzen	Bolt	Boulon	Perno	1,00
8	1000225671	Bolzen	Bolt	Boulon	Perno	1,00
9	1000202251	Halterung	Bracket	Équerre	Soporte	1,00
10	1000202669	Gewindeplatte	Mounting plate	Plaque d'installation	Placa de montaje	1,00
11	1000224190	Feder	Spring	Ressort	Resorte	1,00
12	1000203285	Hülse	Sleeve	Manchon	Manguito	1,00
13	1000249903	Kugelgelenk	Ball joint	Joint sphérique	Junta de bola	1,00
14	1000222688	Gelenkkopf	Swivel head	Tête à rotule	Cabezal giratorio	1,00
15	1000202671	Halter	Bracket	Équerre	Soporte	1,00
16	1000228616	Gummipuffer	Silent block	Silentbloc	Bloque silente	1,00
17	1000203052	Blech	Sheet	Feuille	Chapa	1,00
18	1000202248	Abdeckblech	Cover plate	Panneau de couvercle	Placa de cubierta	1,00
19	1000202246	Abdeckblech	Cover plate	Panneau de couvercle	Placa de cubierta	1,00
20	1000225521	Bolzen	Bolt	Boulon	Perno	1,00
21	1000224701	Bolzen	Bolt	Boulon	Perno	1,00
22	1000206023	Abdeckblech	Cover plate	Panneau de couvercle	Placa de cubierta	1,00
23	1000205029	Abdeckblech	Cover plate	Panneau de couvercle	Placa de cubierta	1,00
24	1000200684	Schiene	Rail	Rail	Riel	2,00
25	1000048892	Schraube	Bolt	Boulon	Perno	1,00

Trittplatte ab 10.2002 Step board from 10-2002 onwards Marchepied de 10-2002 et au-delà Estribo desde 10-2002

Pos.	Artikelnr.	Bezeichnung	Description	Pièce de rechange	Parte de repuesto	Menge
26	1000197234	Schiene	Rail	Rail	Riel	1,00
27	1000035621	Schiene	Rail	Rail	Riel	1,00
28	1000192898	Stopfen	Plug	Prise	Enchufe	2,00
29	1000225389	Bolzen	Bolt	Boulon	Perno	1,00
30	1000170695	Mutter	Nut	Écrou	Tuerca	1,00
31	1000015433	Scheibe	Washer	Rondelle	Disco	2,00
32	1000192893	Stopfen	Plug	Prise	Enchufe	8,00
33	1000228617	Faltenbalg	Bellows	Soufflet	Fuelle	1,00
34	1000228634	Faltenbalg	Bellows	Soufflet	Fuelle	1,00
35	1000223552	Schelle	Clamp	Attache	Abrazadera	1,00
36	1000223548	Schelle	Clamp	Attache	Abrazadera	1,00
37	1000095351	Scheibe	Washer	Rondelle	Disco	2,00
38	1000095358	Ring	Ring	Anneau	Anillo	2,00
39	1000085404	Schraube	Bolt	Boulon	Perno	2,00
40	1000015433	Scheibe	Washer	Rondelle	Disco	2,00
41	1000022017	Federring	Spring washer	Rondelle de ressort	Arandela de resorte	2,00
42	1000020127	Mutter	Nut	Écrou	Tuerca	2,00
43	1000048576	Schraube	Bolt	Boulon	Perno	4,00
44	1000019126	Scheibe	Washer	Rondelle	Disco	1,00
45	1000082242	Schraube	Bolt	Boulon	Perno	1,00
46	1000022016	Federring	Spring washer	Rondelle de ressort	Arandela de resorte	1,00
47	1000015407	Mutter	Nut	Écrou	Tuerca	1,00
48	1000015432	Scheibe	Washer	Rondelle	Disco	1,00
49	1000085493	Schraube	Bolt	Boulon	Perno	2,00
50	1000222572	Schraube	Bolt	Boulon	Perno	1,00



Trittplatte ab 10.2002 Step board from 10-2002 onwards Marchepied de 10-2002 et au-delà Estribo desde 10-2002

Pos.	Artikelnr.	Bezeichnung	Description	Pièce de rechange	Parte de repuesto	Menge
51	1000222810	Schraube	Bolt	Boulon	Perno	4,00
52	1000223005	Scheibe	Washer	Rondelle	Disco	4,00
53	1000015347	Schraube	Bolt	Boulon	Perno	2,00
54	1000015345	Schraube	Bolt	Boulon	Perno	2,00
55	1000019593	?Schraube	Bolt	Boulon	Perno	2,00
56	1000082617	Federring	Spring washer	Rondelle de ressort	Arandela de resorte	2,00
57	1000015406	Mutter	Nut	Écrou	Tuerca	1,00
58	1000222819	Scheibe	Washer	Rondelle	Disco	1,00
59	1000200194	Gitter	Grid	Grille	Rejilla	1,00
60	1000224213	Schraube	Bolt	Boulon	Perno	1,00
61	1000082237	Schraube	Bolt	Boulon	Perno	1,00
62	1000015430	Scheibe	Washer	Rondelle	Disco	1,00

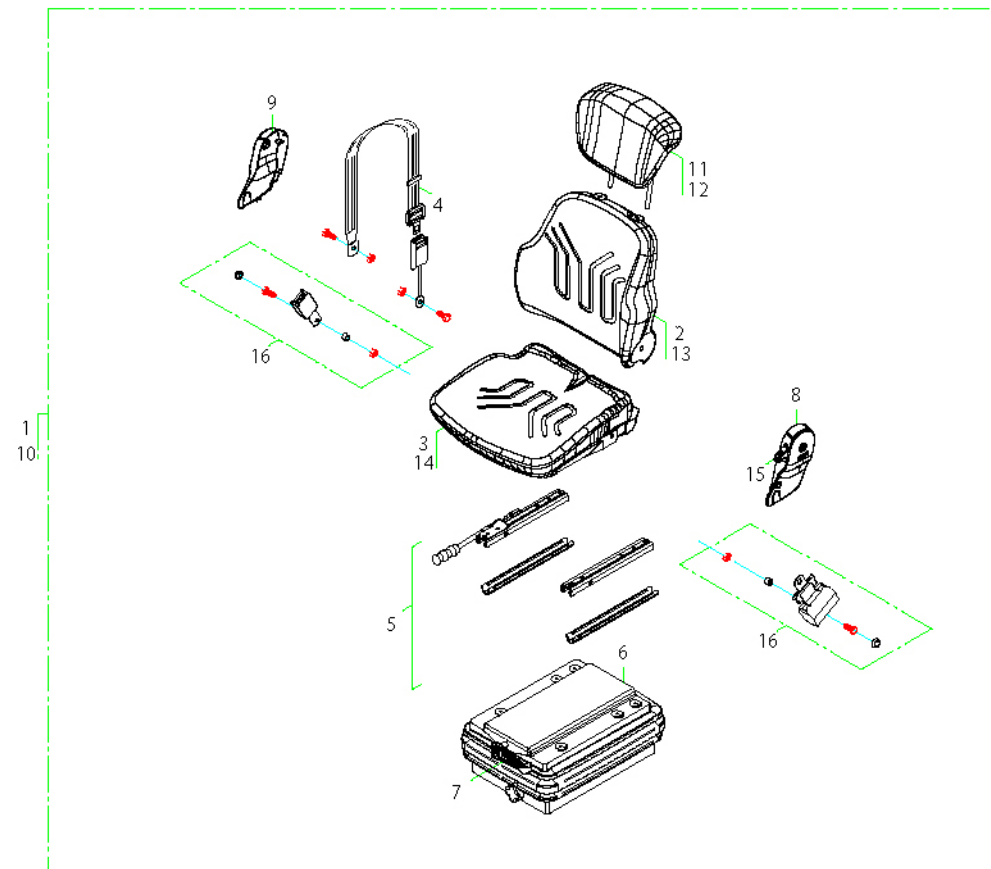

Sitz MSG 83/S721 Seat MSG 83/S721 Siège MSG 83/S721 Asientos MSG 83/S721

Pos.	Artikelnr.	Bezeichnung	Description	Pièce de rechange	Parte de repuesto	Menge	Ausführung
1	1000213649	Fahrersitz	drivers seat	siège conducteur	asiento del conductor	1	KUNSTLEDER
2	1000215095	Sitzpolster	seat upholstery	assise	cojín de asiento	1	KUNSTLEDER
3	1000089496	Sitzpolster	seat upholstery	bourelet	cojín de asiento	1	KUNSTLEDER
4	1000035619	Gurt	belt	ceinture	cinturón	1	
5	1000215096	Verstellschiene	displacement rail	rail à déplacer	carril graduable	1	
6	1000197246	Federung	spring assy	suspension	suspensión	1	
7	1000108194	Knebel	Handle kpl.	Garrot kpl.		1	
8	1000215329	Abdeckung Fahrersitz	seat cover	couvercle du siège du conducteur	cubierta asiento del conductor	1	
9	1000147170	Abdeckung	cover	capot	cubierta	1	
10	1000214139	Fahrersitz	drivers seat	siège conducteur	asiento del conductor	1	Stoffbezug
11	1000085219	Kopfstütze	headrest	support de tête	apoyacabeza	1	KUNSTLEDER
12	1000214138	Kopfstütze	headrest	support de tête	apoyacabeza	1	Stoffbezug
13	1000088411	Rückenpolster	back cushion	dossier du siège	respaldo	1	Stoffbezug
14	1000084945	Sitzpolster	seat upholstery	bourelet	cojín de asiento	1	Stoffbezug
15	1000184830	Griff	handle	manette	manecilla	1	
16	1000021736	Beckengurt	Lap belt	ceinture de bassin	cinturón abdominal	1	

# Motorhaube Bonnet Bonnet Capó

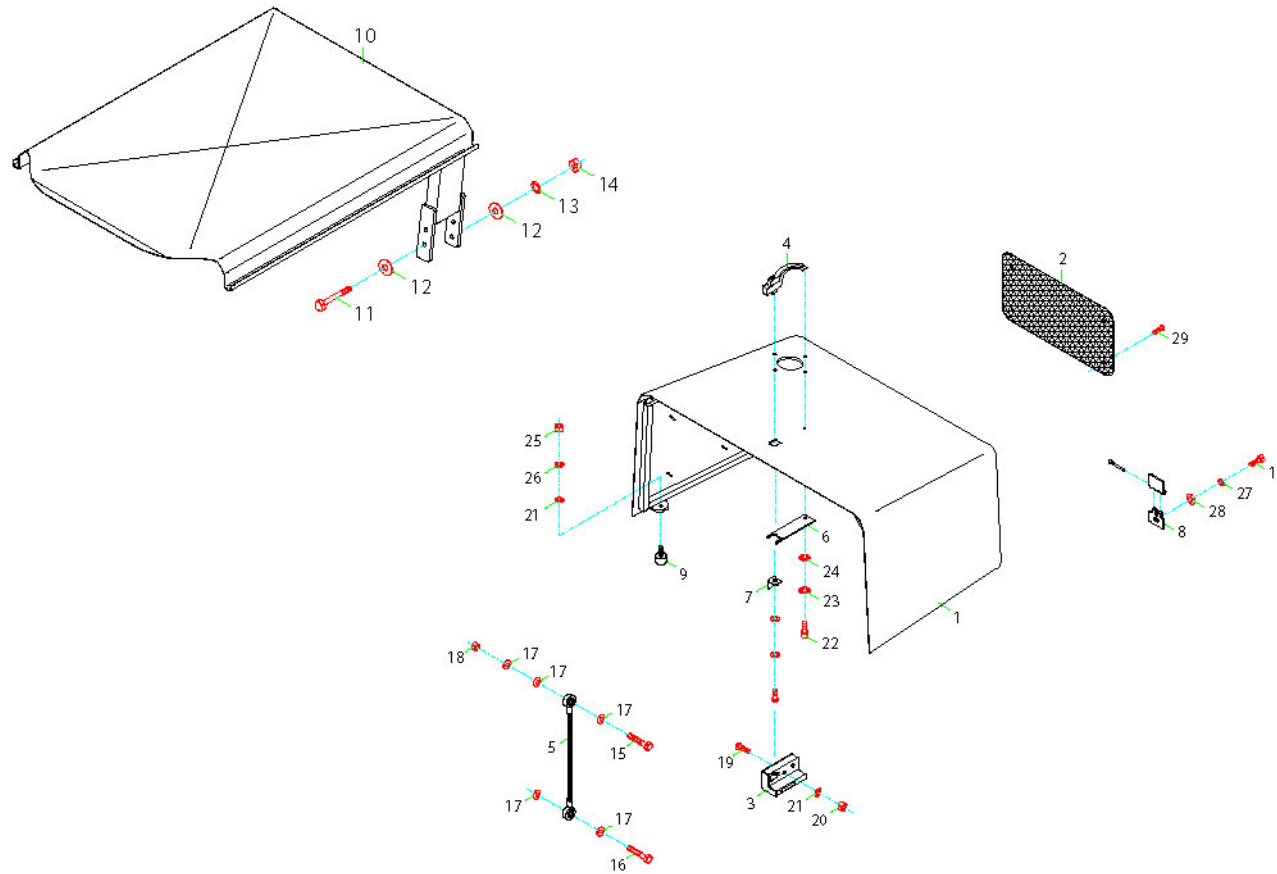

## Motorhaube Bonnet Bonnet Capó

Pos.	Artikelnr.	Bezeichnung	Description	Pièce de rechange	Parte de repuesto	Menge
1	1000202118	Motorhaube	Bonnet	Bonnet	Capó	1
2	1000202666	Gitter	Grid	Grille	Rejilla	1
3	1000223295	Schloß	Latch	Verrou	Retención	1
4	1000193881	Griff	Handle	Poignée	Mango	1
5	1000222727	Seil	Rope	Corde	Soga	1
6	1000202662	Verstärkung	Reinforcement	Renforcement	Refuerzo	1
7	1000205104	Halterung	Bracket	Équerre	Soporte	1
8	1000222618	Scharnier	Hinge	Charnière	Bisagra	1
9	1000228511	Gummipuffer	Silent block	Silentbloc	Bloque silente	1
10	1000202276	Fahrerschutzdach	Safety roof driver	Circuit d'attaque du toit de sécurité	Techo de seguridad conductor	1
11	1000082426	Schraube	Bolt	Boulon	Perno	1
12	1000015433	Scheibe	Washer	Rondelle	Disco	1
13	1000022017	Federring	Spring washer	Rondelle de ressort	Arandela de resorte	1
14	1000020127	Mutter	Nut	Écrou	Tuerca	1
15	1000015346	Schraube	Bolt	Boulon	Perno	1
16	1000085413	Schraube	Bolt	Boulon	Perno	1
17	1000015432	Scheibe	Washer	Rondelle	Disco	1
18	1000015408	Mutter	Nut	Écrou	Tuerca	1
19	1000224073	Schraube	Bolt	Boulon	Perno	1
20	1000015412	Mutter	Nut	Écrou	Tuerca	1
21	1000222819	Scheibe	Washer	Rondelle	Disco	1
22	1000085455	Schraube	Bolt	Boulon	Perno	1
23	1000015430	Scheibe	Washer	Rondelle	Disco	1
24	1000092410	Scheibe	Washer	Rondelle	Disco	1
25	1000015406	Mutter	Nut	Écrou	Tuerca	1

## Motorhaube Bonnet Bonnet Capó

Pos.	Artikelnr.	Bezeichnung	Description	Pièce de rechange	Parte de repuesto	Menge
26	1000082617	Federring	Spring washer	Rondelle de ressort	Arandela de resorte	1
27	1000022016	Federring	Spring washer	Rondelle de ressort	Arandela de resorte	1
28	1000222577	Scheibe	Washer	Rondelle	Disco	1
29	1000224213	Schraube	Bolt	Boulon	Perno	1



**WEIDEMANN**

**Weidemann 1360**

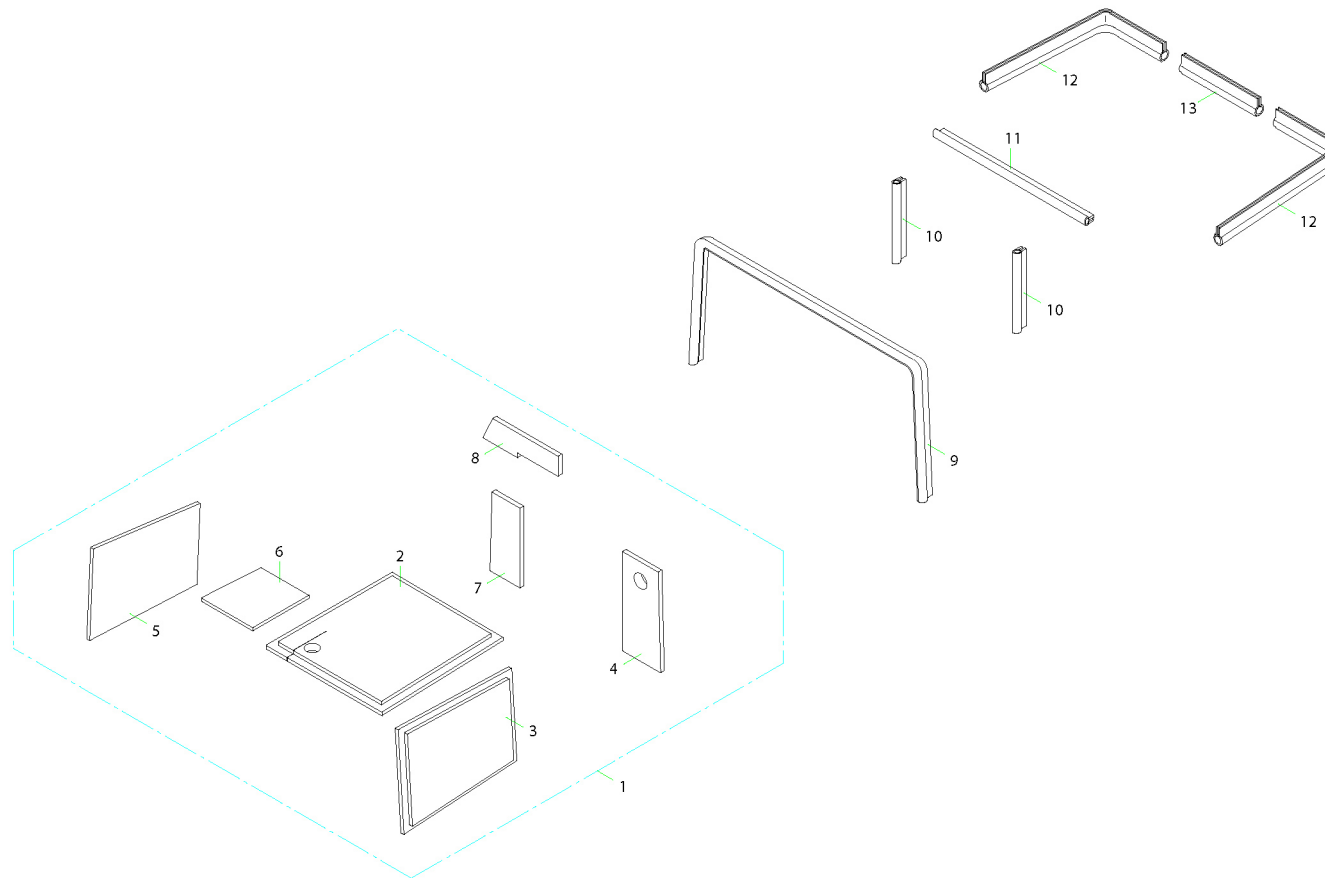



## Dämmatten Silencing foam Mousse insonorisante Espuma silenciadora

Pos.	Artikelnr.	Bezeichnung	Description	Pièce de rechange	Parte de repuesto	Menge
1	1000231642	Dämmattensatz	Set of silencing foam	Jeu de mousse insonorisante	Juego de espuma silenciadora	1
2	1000231648	Dämmatte	Silencing foam	Mousse insonorisante	Espuma silenciadora	1
3	1000231647	Dämmatte	Silencing foam	Mousse insonorisante	Espuma silenciadora	1
4	1000231643	Dämmatte	Silencing foam	Mousse insonorisante	Espuma silenciadora	1
5	1000231644	Dämmatte	Silencing foam	Mousse insonorisante	Espuma silenciadora	1
6	1000231649	Dämmatte	Silencing foam	Mousse insonorisante	Espuma silenciadora	1
7	1000231645	Dämmatte	Silencing foam	Mousse insonorisante	Espuma silenciadora	1
8	1000231646	Dämmatte	Silencing foam	Mousse insonorisante	Espuma silenciadora	1
9	1000228535	Kantenschutz	Edge protection	Protection d'arête	Protección de los bordes	1
10	1000228667	Dichtprofil	Sealing	Scellant	Sellado	1
11	1000228669	Dichtprofil	Sealing	Scellant	Sellado	1
12	1000228545	Kantenschutz	Edge protection	Protection d'arête	Protección de los bordes	1
13	1000228542	Kantenschutz	Edge protection	Protection d'arête	Protección de los bordes	1

Ladeschwinge MV (915) Loading rocker MV (915) Culbuteur de chargement MV (915) Brazo de carga MV (915)

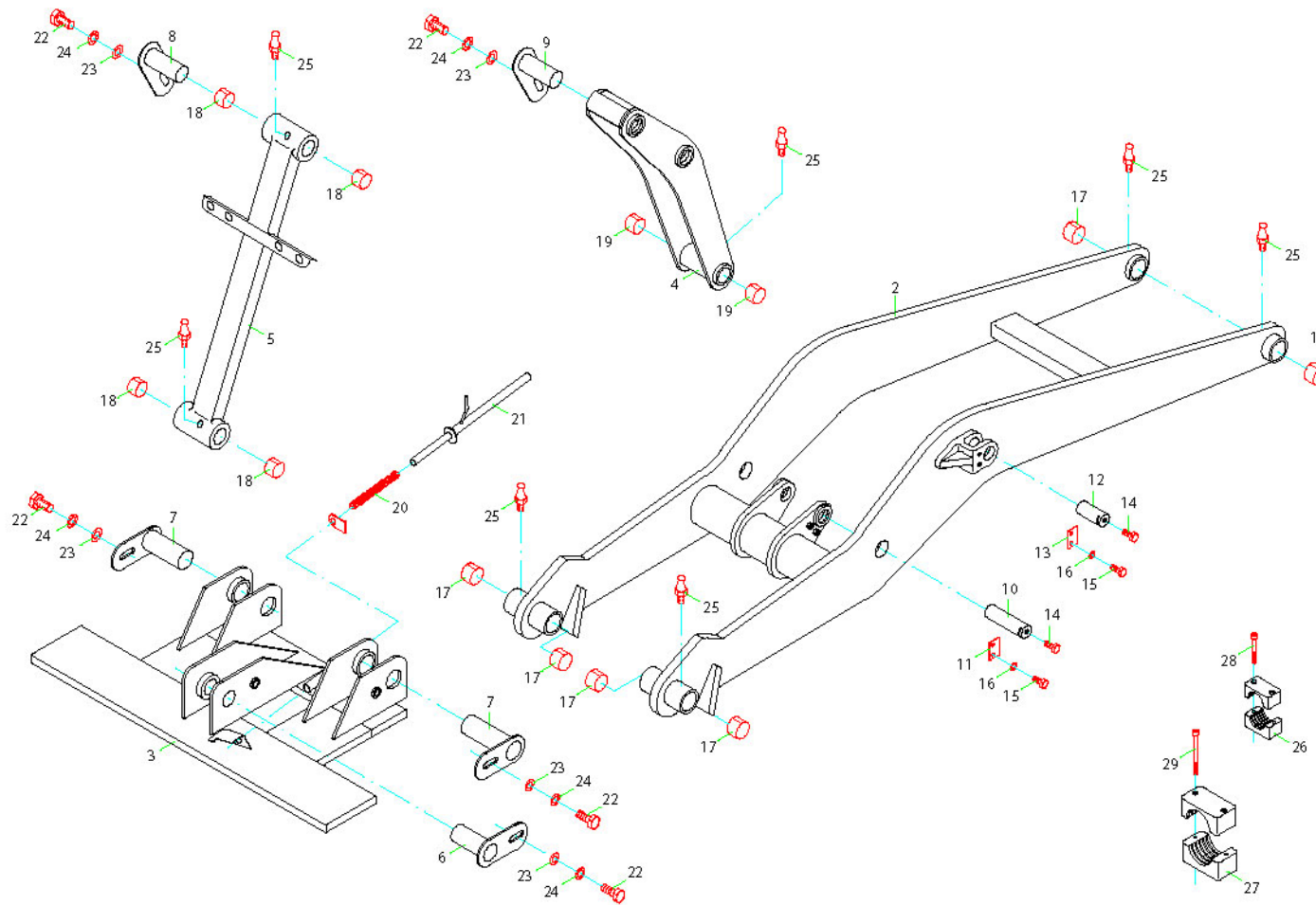

Ladeschwinge MV (915) Loading rocker MV (915) Culbuteur de chargement MV (915) Brazo de carga MV (915)

Pos.	Artikelnr.	Bezeichnung	Description	Pièce de rechange	Parte de repuesto	Menge
1	1000192371	Schwinge	Lifting arm	Bras de levage	Brazo de elevación	1
2	1000192372	Schwinge	Lifting arm	Bras de levage	Brazo de elevación	1
3	1000192374	Aufnahmerahmen	Insert frame	Cadre d'insertion	Bastidor del inserto	1
4	1000192373	Hebel	Lever	Levier	Palanca	1
5	1000192319	Zugstange	Drawbar	Barre d'attelage	Barra de tracción	1
6	1000224293	Bolzen	Bolt	Boulon	Perno	1
7	1000224745	Bolzen	Bolt	Boulon	Perno	1
8	1000224293	Bolzen	Bolt	Boulon	Perno	1
9	1000224744	Bolzen	Bolt	Boulon	Perno	1
10	1000224720	Bolzen	Bolt	Boulon	Perno	1
11	1000196339	Platte	Plate	Plaque	Placa	1
12	1000224248	Bolzen	Bolt	Boulon	Perno	1
13	1000194577	Platte	Plate	Plaque	Placa	1
14	1000015345	Schraube	Bolt	Boulon	Perno	1
15	1000015342	Schraube	Bolt	Boulon	Perno	1
16	1000082617	Federring	Spring washer	Rondelle de ressort	Arandela de resorte	1
17	1000225246	Lager	Bearing	Palier	Cojinete	6
18	1000224656	Lager	Bearing	Palier	Cojinete	4
19	1000225631	Lager	Bearing	Palier	Cojinete	2
	1000224334	Lagersatz	Bearing set	Jeu de paliers	Juego de cojinetes	1
20	1000223116	Feder	Spring	Ressort	Resorte	1
21	1000225370	Bolzen	Bolt	Boulon	Perno	1
22	1000085411	Schraube	Bolt	Boulon	Perno	1
23	1000015432	Scheibe	Washer	Rondelle	Disco	1
24	1000022016	Federring	Spring washer	Rondelle de ressort	Arandela de resorte	1

Ladeschwinge MV (915) Loading rocker MV (915) Culbuteur de chargement MV (915) Brazo de carga MV (915)

Pos.	Artikelnr.	Bezeichnung	Description	Pièce de rechange	Parte de repuesto	Menge
25	1000222726	Schmiernippel	Grease nipple	Raccord graisseur	Boquilla de engrasar	1
26	1000222581	Klemmbackenpaar	Clamping block	Cale	Bloque de sujeción	1
27	1000222657	Klemmbackenpaar	Clamping block	Cale	Bloque de sujeción	1
28	1000015369	Schraube	Bolt	Boulon	Perno	1
29	1000085461	Schraube	Bolt	Boulon	Perno	1



**WEIDEMANN**

**Weidemann 1360**

Ladeschwinge HV (920) Loading rocker HV (920) Culbuteur de chargement HV (920) Brazo de carga HV (920)

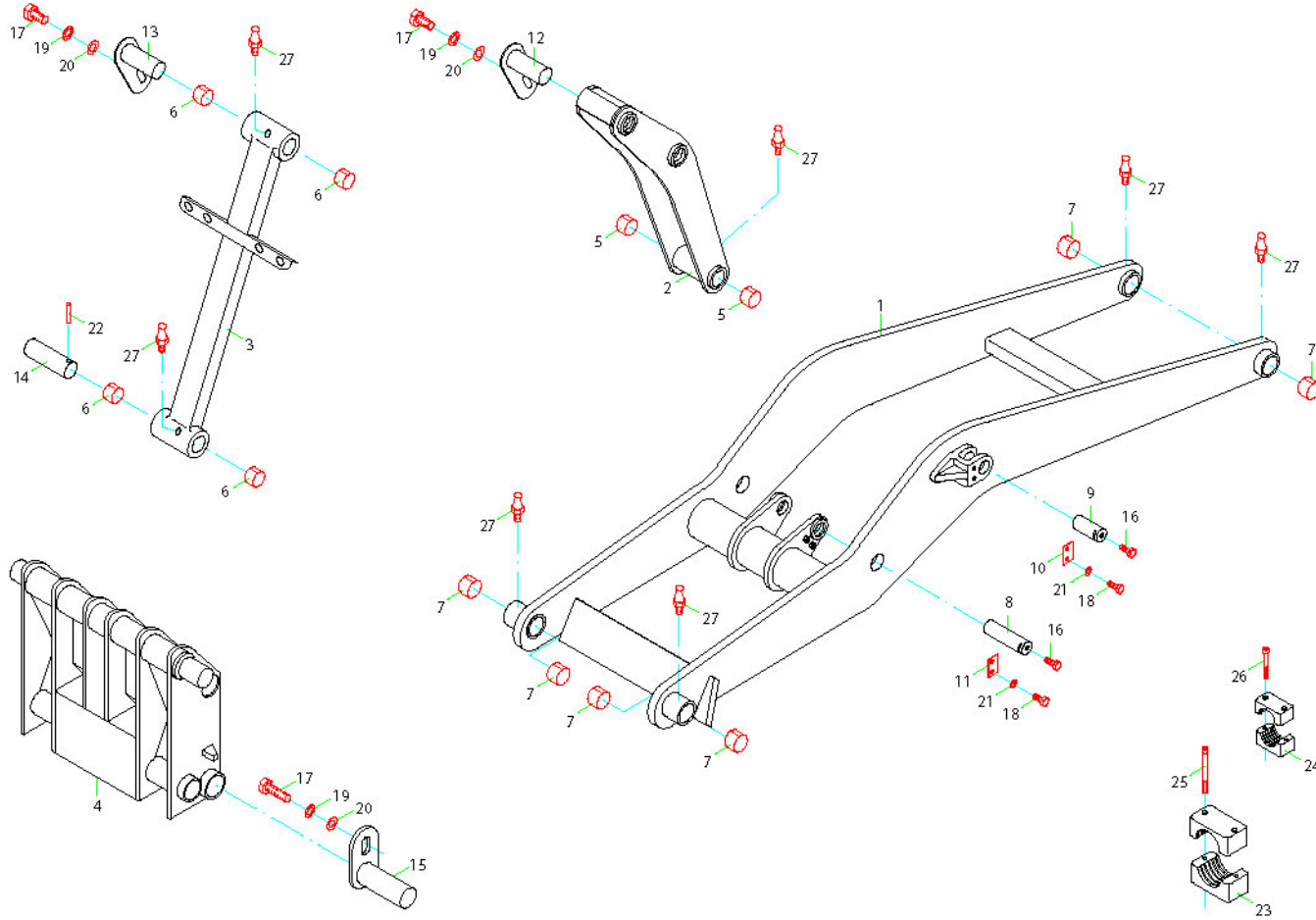

Ladeschwinge HV (920) Loading rocker HV (920) Culbuteur de chargement HV (920) Brazo de carga HV (920)

Pos.	Artikelnr.	Bezeichnung	Description	Pièce de rechange	Parte de repuesto	Menge	Ausführung:
	1000192288	Schwinge	Lifting arm	Bras de levage	Brazo de elevación	1	kpl.
1	1000192289	Schwinge	Lifting arm	Bras de levage	Brazo de elevación	1	
2	1000192373	Hebel	Lever	Levier	Palanca	1	
3	1000192319	Zugstange	Drawbar	Barre d'attelage	Barra de tracción	1	
4	1000192326	Aufnahmerahmen	Insert frame	Cadre d'insertion	Bastidor del inserto	1	
5	1000225631	Lager	Bearing	Palier	Cojinete	2	
6	1000224656	Lager	Bearing	Palier	Cojinete	4	
7	1000225246	Lager	Bearing	Palier	Cojinete	6	
	1000224334	Lagersatz	Bearing set	Jeu de paliers	Juego de cojinetes	1	
8	1000224720	Bolzen	Bolt	Boulon	Perno	1	
9	1000224248	Bolzen	Bolt	Boulon	Perno	1	
10	1000194577	Platte	Plate	Plaque	Placa	1	
11	1000196339	Platte	Plate	Plaque	Placa	1	
12	1000224744	Bolzen	Bolt	Boulon	Perno	1	
13	1000224293	Bolzen	Bolt	Boulon	Perno	1	
14	1000224249	Bolzen	Bolt	Boulon	Perno	1	
15	1000224745	Bolzen	Bolt	Boulon	Perno	1	
16	1000015345	Schraube	Bolt	Boulon	Perno	1	
17	1000085411	Schraube	Bolt	Boulon	Perno	1	
18	1000015342	Schraube	Bolt	Boulon	Perno	1	
19	1000022016	Federring	Spring washer	Rondelle de ressort	Arandela de resorte	1	
20	1000015432	Scheibe	Washer	Rondelle	Disco	1	
21	1000082617	Federring	Spring washer	Rondelle de ressort	Arandela de resorte	1	
22	1000085650	Hülse	Sleeve	Manchon	Manguito	1	
23	1000222657	Klemmbackenpaar	Clamping block	Cale	Bloque de sujeción	1	

Ladeschwinge HV (920) Loading rocker HV (920) Culbuteur de chargement HV (920) Brazo de carga HV (920)

Pos.	Artikelnr.	Bezeichnung	Description	Pièce de rechange	Parte de repuesto	Menge	Ausführung:
24	1000222578	Klemmbackenpaar	Clamping block	Cale	Bloque de sujeción	1	
25	1000085461	Schraube	Bolt	Boulon	Perno	1	
26	1000015369	Schraube	Bolt	Boulon	Perno	1	
27	1000222726	Schmiernippel	Grease nipple	Raccord graisseur	Boquilla de engrasar	1	





**WEIDEMANN**

**Weidemann 1360**

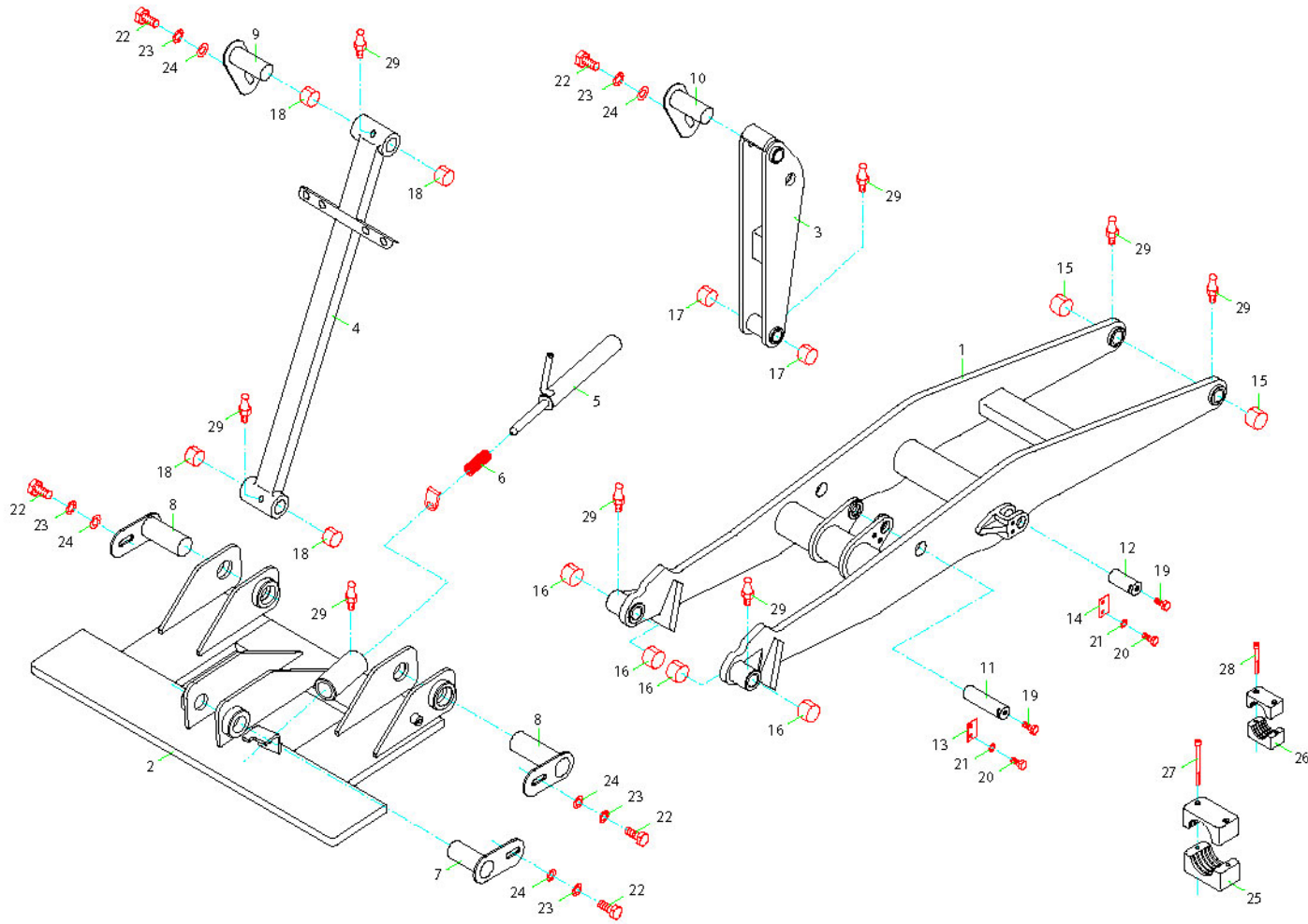

Ladeschwinge MV HH (918) Loading rocker MV HH (918) Culbuteur de chargement MV HH (918) Brazo de carga MV HH (918)

Pos.	Artikelnr.	Bezeichnung	Description	Pièce de rechange	Parte de repuesto	Menge	Ausführung:
	1000192377	Schwinge	Lifting arm	Bras de levage	Brazo de elevación	1	kpl.
1	1000192378	Schwinge	Lifting arm	Bras de levage	Brazo de elevación	1	
2	1000192280	Aufnahmerahmen	Insert frame	Cadre d'insertion	Bastidor del inserto	1	
3	1000192379	Hebel	Lever	Levier	Palanca	1	
4	1000192380	Zugstange	Drawbar	Barre d'attelage	Barra de tracción	1	
5	1000225370	Bolzen	Bolt	Boulon	Perno	1	
6	1000223116	Feder	Spring	Ressort	Resorte	1	
7	1000224293	Bolzen	Bolt	Boulon	Perno	1	
8	1000224294	Bolzen	Bolt	Boulon	Perno	1	
9	1000224293	Bolzen	Bolt	Boulon	Perno	1	
10	1000224744	Bolzen	Bolt	Boulon	Perno	1	
11	1000224720	Bolzen	Bolt	Boulon	Perno	1	
12	1000224248	Bolzen	Bolt	Boulon	Perno	1	
13	1000196339	Platte	Plate	Plaque	Placa	1	
14	1000194577	Platte	Plate	Plaque	Placa	1	
15	1000225246	Lager	Bearing	Palier	Cojinete	2	
16	1000224665	Lager	Bearing	Palier	Cojinete	4	
17	1000225631	Lager	Bearing	Palier	Cojinete	2	
18	1000224656	Lager	Bearing	Palier	Cojinete	4	
	1000225615	Lagersatz	Bearing set	Jeu de paliers	Juego de cojinetes	1	
19	1000015345	Schraube	Bolt	Boulon	Perno	1	
20	1000015342	Schraube	Bolt	Boulon	Perno	1	
21	1000082617	Federring	Spring washer	Rondelle de ressort	Arandela de resorte	1	
22	1000085411	Schraube	Bolt	Boulon	Perno	1	
23	1000022016	Federring	Spring washer	Rondelle de ressort	Arandela de resorte	1	

Ladeschwinge MV HH (918) Loading rocker MV HH (918) Culbuteur de chargement MV HH (918) Brazo de carga MV HH (918)

Pos.	Artikelnr.	Bezeichnung	Description	Pièce de rechange	Parte de repuesto	Menge	Ausführung:
24	1000015432	Scheibe	Washer	Rondelle	Disco	1	
25	1000222657	Klemmbackenpaar	Clamping block	Cale	Bloque de sujeción	1	
26	1000222578	Klemmbackenpaar	Clamping block	Cale	Bloque de sujeción	1	
27	1000085461	Schraube	Bolt	Boulon	Perno	1	
28	1000015369	Schraube	Bolt	Boulon	Perno	1	
29	1000222726	Schmiernippel	Grease nipple	Raccord graisseur	Boquilla de engrasar	1	



**WEIDEMANN**

**Weidemann 1360**

Ladeschwinge HV HH (921) Loading rocker HV HH (921) Culbuteur de chargement HV HH (921) Brazo de carga HV HH (921)

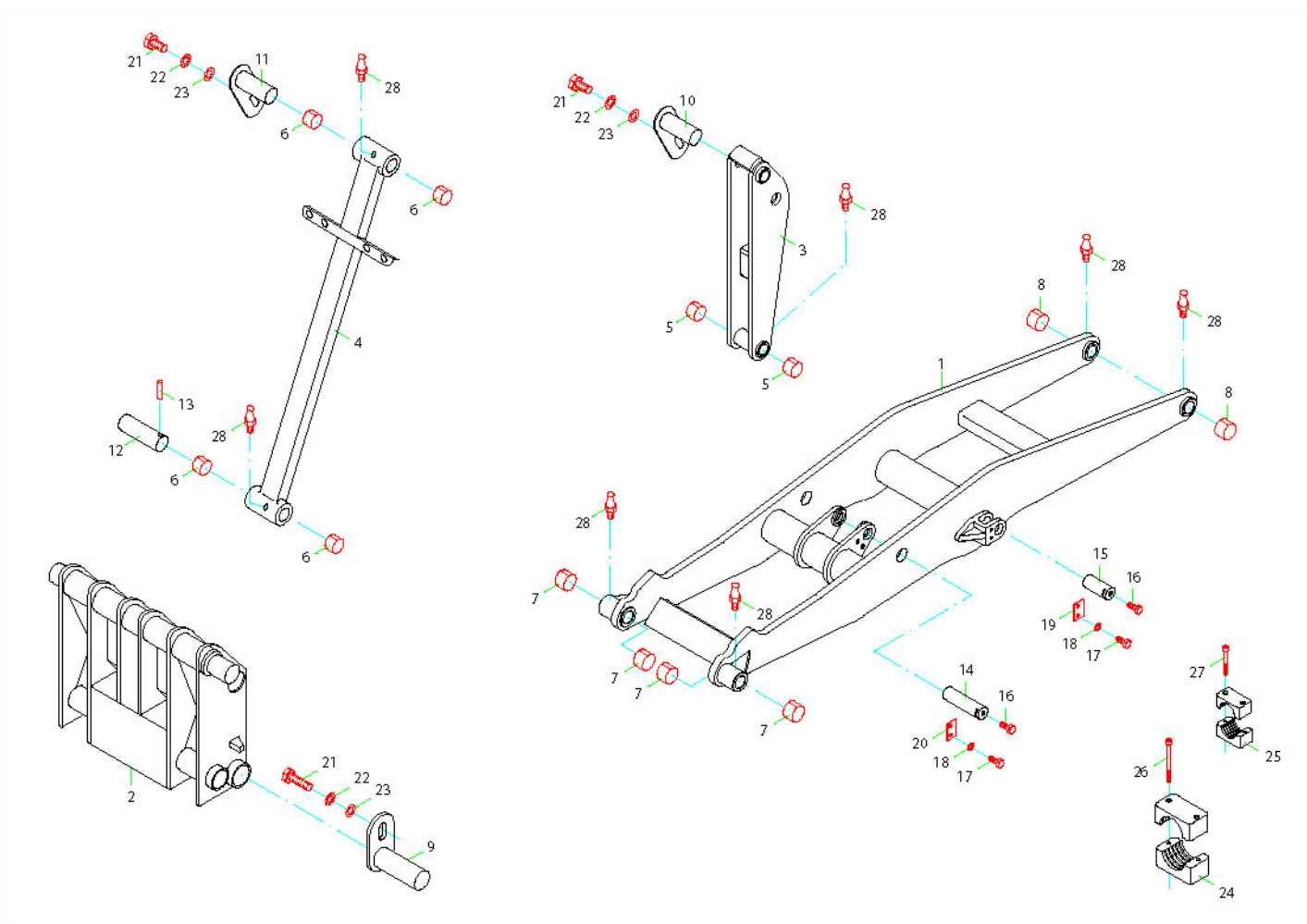

Ladeschwinge HV HH (921) Loading rocker HV HH (921) Culbuteur de chargement HV HH (921) Brazo de carga HV HH (921)

Pos.	Artikelnr.	Bezeichnung	Description	Pièce de rechange	Parte de repuesto	Menge	Ausführung:
	1000192290	Schwinge	Lifting arm	Bras de levage	Brazo de elevación	1	kpl.
1	1000192291	Schwinge	Lifting arm	Bras de levage	Brazo de elevación	1	
2	1000192292	Aufnahmerahmen	Insert frame	Cadre d'insertion	Bastidor del inserto	1	
3	1000192379	Hebel	Lever	Levier	Palanca	1	
4	1000192380	Zugstange	Drawbar	Barre d'attelage	Barra de tracción	1	
5	1000225631	Lager	Bearing	Palier	Cojinete	2	
6	1000224656	Lager	Bearing	Palier	Cojinete	4	
7	1000224665	Lager	Bearing	Palier	Cojinete	4	
8	1000225246	Lager	Bearing	Palier	Cojinete	2	
	1000225615	Lagersatz	Bearing set	Jeu de paliers	Juego de cojinetes	1	
9	1000224294	Bolzen	Bolt	Boulon	Perno	1	
10	1000224744	Bolzen	Bolt	Boulon	Perno	1	
11	1000224293	Bolzen	Bolt	Boulon	Perno	1	
12	1000224249	Bolzen	Bolt	Boulon	Perno	1	
13	1000085647	Hülse	Sleeve	Manchon	Manguito	1	
14	1000224720	Bolzen	Bolt	Boulon	Perno	1	
15	1000224248	Bolzen	Bolt	Boulon	Perno	1	
16	1000015345	Schraube	Bolt	Boulon	Perno	1	
17	1000015342	Schraube	Bolt	Boulon	Perno	1	
18	1000082617	Federring	Spring washer	Rondelle de ressort	Arandela de resorte	1	
19	1000194577	Platte	Plate	Plaque	Placa	1	
20	1000196339	Platte	Plate	Plaque	Placa	1	
21	1000085411	Schraube	Bolt	Boulon	Perno	1	
22	1000022016	Federring	Spring washer	Rondelle de ressort	Arandela de resorte	1	
23	1000015432	Scheibe	Washer	Rondelle	Disco	1	

Ladeschwinge HV HH (921) Loading rocker HV HH (921) Culbuteur de chargement HV HH (921) Brazo de carga HV HH (921)

Pos.	Artikelnr.	Bezeichnung	Description	Pièce de rechange	Parte de repuesto	Menge	Ausführung:
24	1000222657	Klemmbackenpaar	Clamping block	Cale	Bloque de sujeción	1	
25	1000222578	Klemmbackenpaar	Clamping block	Cale	Bloque de sujeción	1	
26	1000085461	Schraube	Bolt	Boulon	Perno	1	
27	1000015369	Schraube	Bolt	Boulon	Perno	1	
28	1000222726	Schmiernippel	Grease nipple	Raccord graisseur	Boquilla de engrasar	1	





**WEIDEMANN**

**Weidemann 1360**

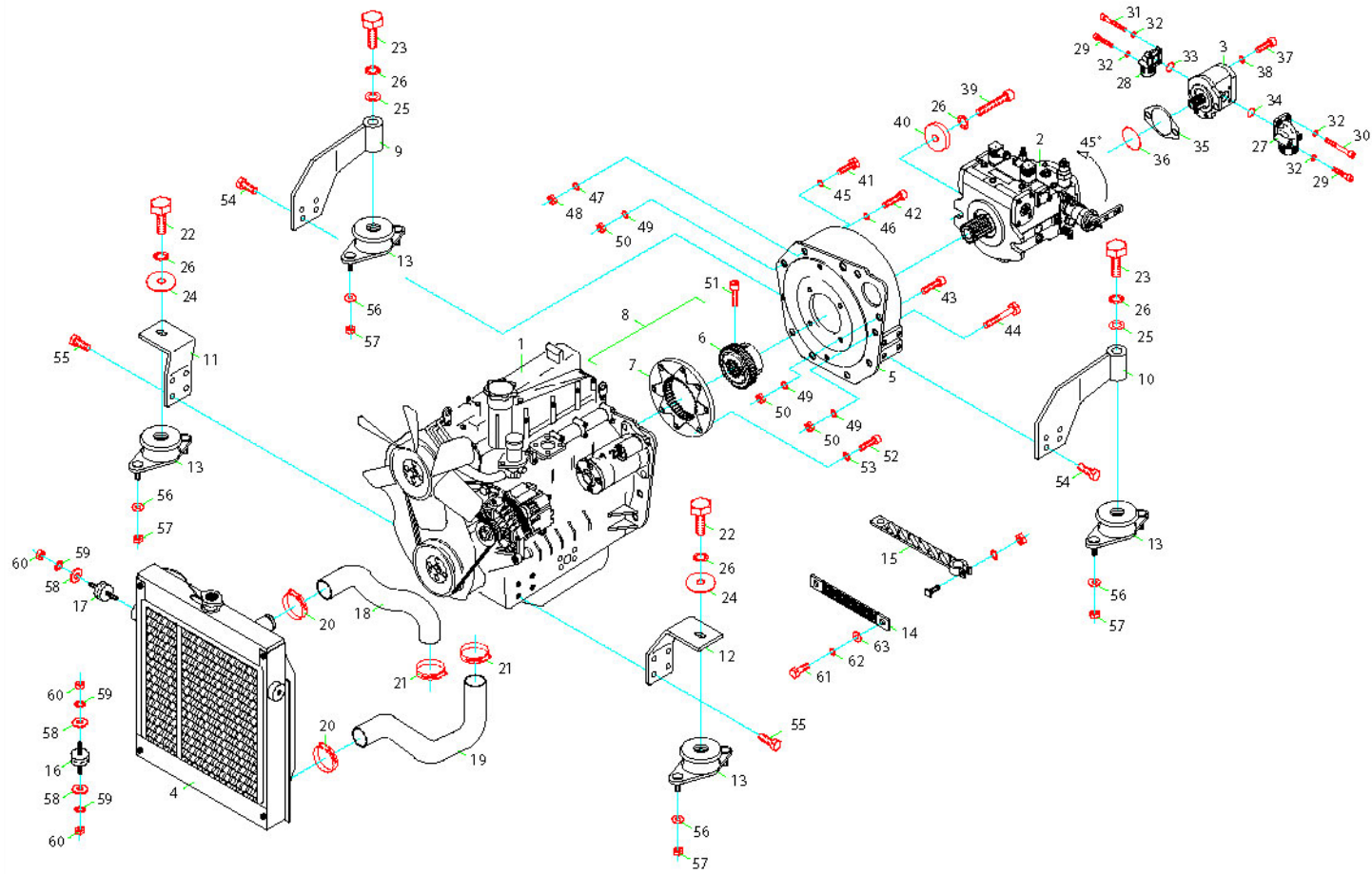

**Motor P33/34 Engine P33/34 Moteur P33/34 Motor P33/34**

Pos.	Artikelnr.	Bezeichnung	Description	Pièce de rechange	Parte de repuesto	Menge	Ausführung:
1	1000213283	Dieselmotor	Diesel engine	Moteur diesel	Motor Diesel	1	103-15 m.Anbauteilen
	1000213283	Dieselmotor	Diesel engine	Moteur diesel	Motor Diesel	1	103-15 o.Anbauteilen
	1000205429	Dieselmotor	Diesel engine	Moteur diesel	Motor Diesel	1	403C-15 m.Anbauteilen
2	1000205858	Ölpumpe	Oil pump	Pompe à huile	Bomba de aceite	1	
	1000224305	Dichtsatz	Service kit	Trousse de service	Kit de servicio	1	
3	1000199130	Pumpe	Pump	Pompe	Bomba	1	14 ccm
	1000028062	Pumpe	Pump	Pompe	Bomba	1	16 ccm
	1000224657	Dichtsatz	Service kit	Trousse de service	Kit de servicio	1	
4	1000204935	Kühler	Cooler	Refroidisseur	Enfriador	1	
	1000204935	Wasserkühler	Watercooler	Refroidisseur à eau	Refrigerante de agua	1	
	1000204935	Ölkühler	Oil cooler	Refroidisseur d'huile	Refrigerador de aceite	1	
5	1000226791	Anbauflansch	Loose flange	Bride desserrée	Abrazadera suelta	1	
6	1000074683	Nabe	Hub	Concentrateur	Cubo	1	
7	1000073349	Flansch	Flange	Bride	Brida	1	
8	1000226799	Kupplung	Coupling	Couplage	Acoplamiento	1	
9	1000201581	Halterung	Bracket	Équerre	Soporte	1	
10	1000201580	Halterung	Bracket	Équerre	Soporte	1	
11	1000200375	Halterung	Bracket	Équerre	Soporte	1	
12	1000200374	Halterung	Bracket	Équerre	Soporte	1	
13	1000228633	Gummipuffer	Silent block	Silentbloc	Bloque silente	1	
14	1000198967	Kabel	Cable	Câble	Cable	1	
15	1000198976	Kabel	Cable	Câble	Cable	1	
16	1000228558	Gummipuffer	Silent block	Silentbloc	Bloque silente	1	
17	1000228561	Gummipuffer	Silent block	Silentbloc	Bloque silente	1	
18	1000219034	Schlauch	Hose	Boyau	Manguera	1	

**Motor P33/34 Engine P33/34 Moteur P33/34 Motor P33/34**

Pos.	Artikelnr.	Bezeichnung	Description	Pièce de rechange	Parte de repuesto	Menge	Ausführung:
19	1000219280	Schlauch	Hose	Boyau	Manguera	1	
20	1000223543	Schelle	Clamp	Attache	Abrazadera	1	
21	1000223539	Schelle	Clamp	Attache	Abrazadera	1	
22	1000015347	Schraube	Bolt	Boulon	Perno	1	
23	1000222957	Schraube	Bolt	Boulon	Perno	1	
24	1000223005	Scheibe	Washer	Rondelle	Disco	1	
25	1000015433	Scheibe	Washer	Rondelle	Disco	1	
26	1000022017	Federring	Spring washer	Rondelle de ressort	Arandela de resorte	1	
27	1000021697	Verschraubung	Screw coupling	Couplage fileté	Acoplamiento roscado	1	
28	1000021696	Verschraubung	Screw coupling	Couplage fileté	Acoplamiento roscado	1	
29	1000048165	Schraube	Bolt	Boulon	Perno	1	
30	1000085460	Schraube	Bolt	Boulon	Perno	1	
31	1000048166	Schraube	Bolt	Boulon	Perno	1	
32	1000015444	Federring	Spring washer	Rondelle de ressort	Arandela de resorte	1	
33	1000224646	Ring	Ring	Anneau	Anillo	1	
34	1000224648	Ring	Ring	Anneau	Anillo	1	
35	1000225421	Dichtung	Gasket	Garniture	Junta de estanqueidad	1	
36	1000224910	Ring	Ring	Anneau	Anillo	1	
37	1000015376	Schraube	Bolt	Boulon	Perno	1	
38	1000015432	Scheibe	Washer	Rondelle	Disco	1	
39	1000085476	Schraube	Bolt	Boulon	Perno	1	
40	1000222611	Scheibe	Washer	Rondelle	Disco	1	
41	1000015376	Schraube	Bolt	Boulon	Perno	1	
42	1000085469	Schraube	Bolt	Boulon	Perno	1	
43	1000048179	Schraube	Bolt	Boulon	Perno	1	

**Motor P33/34 Engine P33/34 Moteur P33/34 Motor P33/34**

Pos.	Artikelnr.	Bezeichnung	Description	Pièce de rechange	Parte de repuesto	Menge	Ausführung:
44	1000085471	Schraube	Bolt	Boulon	Perno	1	
45	1000015432	Scheibe	Washer	Rondelle	Disco	1	
46	1000015432	Scheibe	Washer	Rondelle	Disco	1	
47	1000022016	Federring	Spring washer	Rondelle de ressort	Arandela de resorte	1	
48	1000015407	Mutter	Nut	Écrou	Tuerca	1	
49	1000022016	Federring	Spring washer	Rondelle de ressort	Arandela de resorte	1	
50	1000015407	Mutter	Nut	Écrou	Tuerca	1	
51	1000223197	Schraube	Bolt	Boulon	Perno	1	
52	1000082491	Schraube	Bolt	Boulon	Perno	1	
53	1000082617	Federring	Spring washer	Rondelle de ressort	Arandela de resorte	1	
54	1000015347	Schraube	Bolt	Boulon	Perno	1	
55	1000222973	Schraube	Bolt	Boulon	Perno	1	
56	1000222552	Scheibe	Washer	Rondelle	Disco	1	
57	1000015412	Mutter	Nut	Écrou	Tuerca	1	
58	1000222577	Scheibe	Washer	Rondelle	Disco	1	
59	1000022016	Federring	Spring washer	Rondelle de ressort	Arandela de resorte	1	
60	1000015407	Mutter	Nut	Écrou	Tuerca	1	
61	1000015345	Schraube	Bolt	Boulon	Perno	1	
62	1000022016	Federring	Spring washer	Rondelle de ressort	Arandela de resorte	1	
63	1000015432	Scheibe	Washer	Rondelle	Disco	1	

Motor P43 Engine P43 Moteur P43 Motor P43

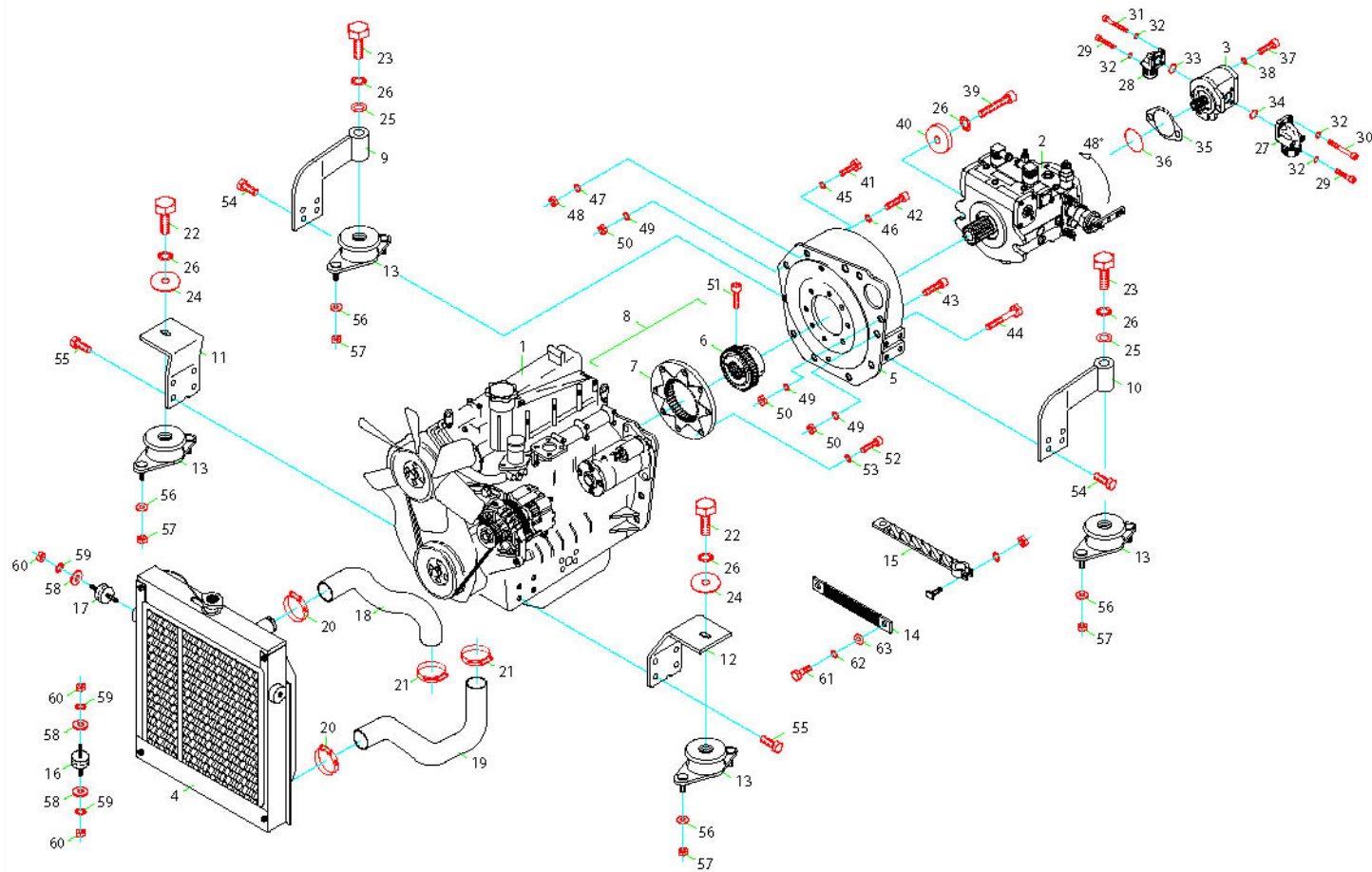

**Motor P43 Engine P43 Moteur P43 Motor P43**

Pos.	Artikelnr.	Bezeichnung	Description	Pièce de rechange	Parte de repuesto	Menge	Ausführung:
1	1000201555	Dieselmotor	Diesel engine	Moteur diesel	Motor Diesel	1	m.Anbauteilen
	1000202755	Dieselmotor	Diesel engine	Moteur diesel	Motor Diesel	1	p.Anbauteilen
2	1000205858	Ölpumpe	Oil pump	Pompe à huile	Bomba de aceite	1	
	1000224305	Dichtsatz	Service kit	Trousse de service	Kit de servicio	1	
3	1000199130	Pumpe	Pump	Pompe	Bomba	1	
	1000224657	Dichtsatz	Service kit	Trousse de service	Kit de servicio	1	
4	1000204935	Kühler	Cooler	Refroidisseur	Enfriador	1	
	1000202681	Wasserkühler	Watercooler	Refroidisseur à eau	Refrigerante de agua	1	
	1000202386	Ölkühler	Oil cooler	Refroidisseur d'huile	Refrigerador de aceite	1	
5	1000226792	Anbauflansch	Loose flange	Bride desserrée	Abrazadera suelta	1	
6	1000074683	Nabe	Hub	Concentrateur	Cubo	1	
7	1000073349	Flansch	Flange	Bride	Brida	1	
8	1000226799	Kupplung	Coupling	Couplage	Acoplamiento	1	
9	1000201591	Halterung	Bracket	Équerre	Soporte	1	
10	1000201581	Halterung	Bracket	Équerre	Soporte	1	
11	1000201593	Halterung	Bracket	Équerre	Soporte	1	
12	1000201592	Halterung	Bracket	Équerre	Soporte	1	
13	1000228585	Gummipuffer	Silent block	Silentbloc	Bloque silente	1	
14	1000198967	Kabel	Cable	Câble	Cable	1	
15	1000198976	Kabel	Cable	Câble	Cable	1	
16	1000228558	Gummipuffer	Silent block	Silentbloc	Bloque silente	1	
17	1000228561	Gummipuffer	Silent block	Silentbloc	Bloque silente	1	
18	1000219034	Schlauch	Hose	Boyau	Manguera	1	
19	1000219280	Schlauch	Hose	Boyau	Manguera	1	
20	1000223543	Schelle	Clamp	Attache	Abrazadera	1	

**Motor P43 Engine P43 Moteur P43 Motor P43**

Pos.	Artikelnr.	Bezeichnung	Description	Pièce de rechange	Parte de repuesto	Menge	Ausführung:
21	1000223539	Schelle	Clamp	Attache	Abrazadera	1	
22	1000015347	Schraube	Bolt	Boulon	Perno	1	
23	1000222957	Schraube	Bolt	Boulon	Perno	1	
24	1000223005	Scheibe	Washer	Rondelle	Disco	1	
25	1000015432	Scheibe	Washer	Rondelle	Disco	1	
26	1000022017	Federring	Spring washer	Rondelle de ressort	Arandela de resorte	1	
27	1000021697	Verschraubung	Screw coupling	Couplage fileté	Acoplamiento roscado	1	
28	1000021696	Verschraubung	Screw coupling	Couplage fileté	Acoplamiento roscado	1	
29	1000048165	Schraube	Bolt	Boulon	Perno	1	
30	1000085460	Schraube	Bolt	Boulon	Perno	1	
31	1000048166	Schraube	Bolt	Boulon	Perno	1	
32	1000015444	Federring	Spring washer	Rondelle de ressort	Arandela de resorte	1	
33	1000224646	Ring	Ring	Anneau	Anillo	1	
34	1000224648	Ring	Ring	Anneau	Anillo	1	
35	1000225421	Dichtung	Gasket	Garniture	Junta de estanqueidad	1	
36	1000224910	Ring	Ring	Anneau	Anillo	1	
37	1000015376	Schraube	Bolt	Boulon	Perno	1	
38	1000022016	Federring	Spring washer	Rondelle de ressort	Arandela de resorte	1	
39	1000085476	Schraube	Bolt	Boulon	Perno	1	
40	1000222611	Scheibe	Washer	Rondelle	Disco	1	
41	1000015376	Schraube	Bolt	Boulon	Perno	1	
42	1000015376	Schraube	Bolt	Boulon	Perno	1	
43	1000048179	Schraube	Bolt	Boulon	Perno	1	
44	1000085471	Schraube	Bolt	Boulon	Perno	1	
45	1000015432	Scheibe	Washer	Rondelle	Disco	1	





**Motor P43 Engine P43 Moteur P43 Motor P43**

Pos.	Artikelnr.	Bezeichnung	Description	Pièce de rechange	Parte de repuesto	Menge	Ausführung:
46	1000015432	Scheibe	Washer	Rondelle	Disco	1	
47	1000022017	Federring	Spring washer	Rondelle de ressort	Arandela de resorte	1	
48	1000049000	Mutter	Nut	Écrou	Tuerca	1	
49	1000022016	Federring	Spring washer	Rondelle de ressort	Arandela de resorte	1	
50	1000015407	Mutter	Nut	Écrou	Tuerca	1	
51	1000223197	Schraube	Bolt	Boulon	Perno	1	
52	1000082491	Schraube	Bolt	Boulon	Perno	1	
53	1000082617	Federring	Spring washer	Rondelle de ressort	Arandela de resorte	1	
54	1000015347	Schraube	Bolt	Boulon	Perno	1	
55	1000222973	Schraube	Bolt	Boulon	Perno	1	
56	1000222552	Scheibe	Washer	Rondelle	Disco	1	
57	1000015412	Mutter	Nut	Écrou	Tuerca	1	
58	1000222577	Scheibe	Washer	Rondelle	Disco	1	
59	1000022016	Federring	Spring washer	Rondelle de ressort	Arandela de resorte	1	
60	1000015407	Mutter	Nut	Écrou	Tuerca	1	
61	1000015345	Schraube	Bolt	Boulon	Perno	1	
62	1000022016	Federring	Spring washer	Rondelle de ressort	Arandela de resorte	1	
63	1000015432	Scheibe	Washer	Rondelle	Disco	1	



Motor P45 Engine P45 Moteur P45 Motor P45

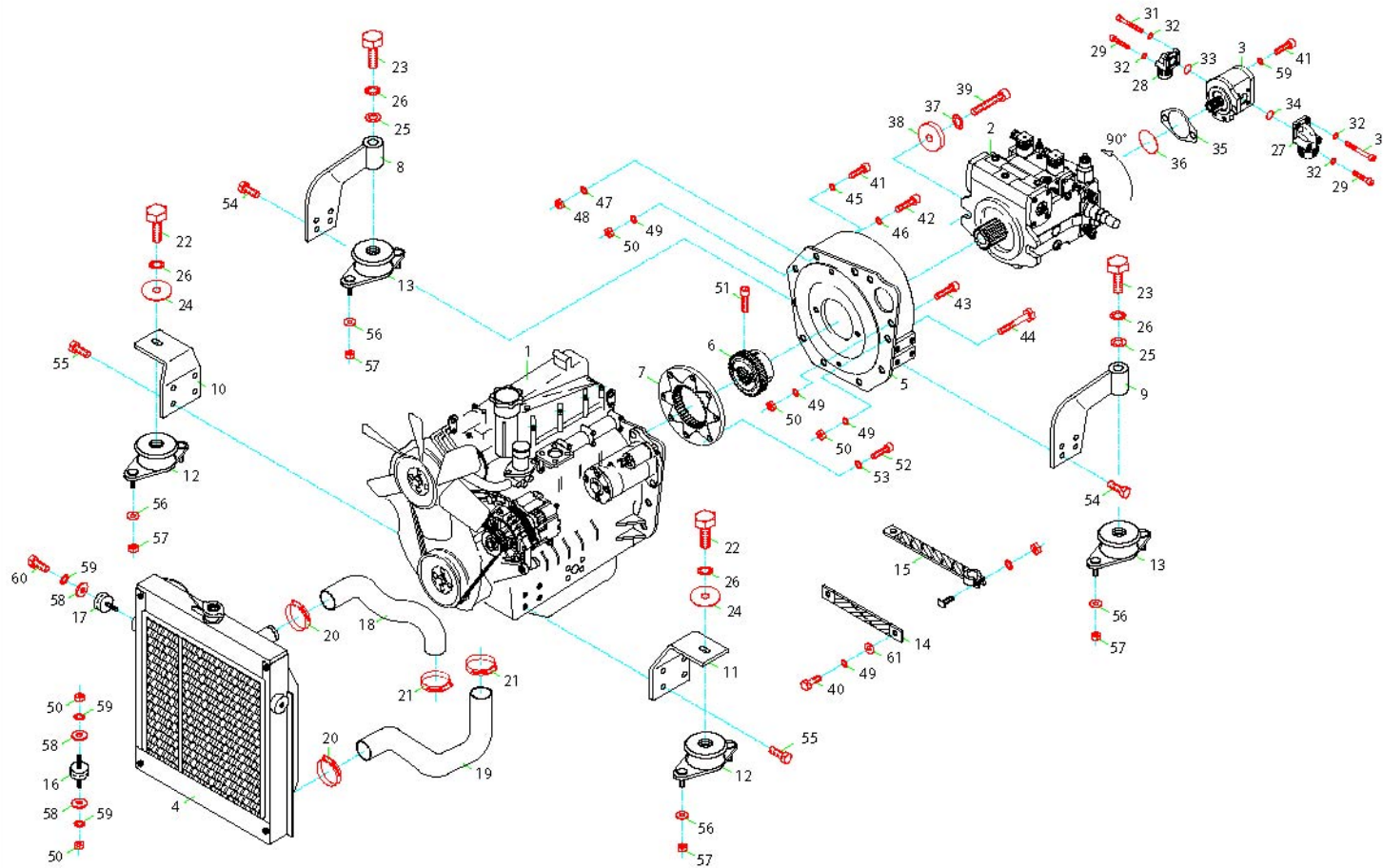

**Motor P45 Engine P45 Moteur P45 Motor P45**

Pos.	Artikelnr.	Bezeichnung	Description	Pièce de rechange	Parte de repuesto	Menge	Ausführung:
1	1000206421	Dieselmotor	Diesel engine	Moteur diesel	Motor Diesel	1,00	
2	1000204448	Ölpumpe	Oil pump	Pompe à huile	Bomba de aceite	1,00	
	1000192768	Ölpumpe	Oil pump	Pompe à huile	Bomba de aceite	1,00	WÜ
3	1000199136	Pumpe	Pump	Pompe	Bomba	1,00	
	1000224657	Dichtsatz	Service kit	Trousse de service	Kit de servicio	1,00	
4	1000204935	Kühler	Cooler	Refroidisseur	Enfriador	1,00	
	1000202681	Wasserkühler	Watercooler	Refroidisseur à eau	Refrigerante de agua	1,00	
	1000202386	Ölkühler	Oil cooler	Refroidisseur d'huile	Refrigerador de aceite	1,00	
5	1000226625	Anbaufansch	Loose flange	Bride desserrée	Abrazadera suelta	1,00	
6	1000075085	Nabe	Hub	Concentrateur	Cubo	1,00	
7	1000073349	Flansch	Flange	Bride	Brida	1,00	
8	1000201596	Halterung	Bracket	Équerre	Soporte	1,00	
9	1000201595	Halterung	Bracket	Équerre	Soporte	1,00	
10	1000201598	Halterung	Bracket	Équerre	Soporte	1,00	
11	1000201597	Halterung	Bracket	Équerre	Soporte	1,00	
12	1000228610	Gummipuffer	Silent block	Silentbloc	Bloque silente	2,00	
13	1000228613	Gummipuffer	Silent block	Silentbloc	Bloque silente	2,00	
14	1000198967	Kabel	Cable	Câble	Cable	1,00	
15	1000198976	Kabel	Cable	Câble	Cable	1,00	
16	1000228561	Gummipuffer	Silent block	Silentbloc	Bloque silente	1,00	
17	1000228562	Gummipuffer	Silent block	Silentbloc	Bloque silente	1,00	
18	1000219034	Schlauch	Hose	Boyau	Manguera	1,00	
19	1000219280	Schlauch	Hose	Boyau	Manguera	1,00	
20	1000223542	Schelle	Clamp	Attache	Abrazadera	1,00	
21	1000223538	Schelle	Clamp	Attache	Abrazadera	1,00	



**Motor P45 Engine P45 Moteur P45 Motor P45**

Pos.	Artikelnr.	Bezeichnung	Description	Pièce de rechange	Parte de repuesto	Menge	Ausführung:
22	1000015347	Schraube	Bolt	Boulon	Perno	1,00	
23	1000047393	Schraube	Bolt	Boulon	Perno	1,00	
24	1000223005	Scheibe	Washer	Rondelle	Disco	1,00	
25	1000015433	Scheibe	Washer	Rondelle	Disco	1,00	
26	1000022017	Federring	Spring washer	Rondelle de ressort	Arandela de resorte	1,00	
27	1000021697	Verschraubung	Screw coupling	Couplage fileté	Acoplamiento roscado	1,00	
28	1000021696	Verschraubung	Screw coupling	Couplage fileté	Acoplamiento roscado	1,00	
29	1000048165	Schraube	Bolt	Boulon	Perno	1,00	
30	1000085460	Schraube	Bolt	Boulon	Perno	1,00	
31	1000048166	Schraube	Bolt	Boulon	Perno	1,00	
32	1000015444	Federring	Spring washer	Rondelle de ressort	Arandela de resorte	1,00	
33	1000224646	Ring	Ring	Anneau	Anillo	1,00	
34	1000224648	Ring	Ring	Anneau	Anillo	1,00	
35	1000225421	Dichtung	Gasket	Garniture	Junta de estanqueidad	1,00	
36	1000224910	Ring	Ring	Anneau	Anillo	1,00	
37	1000082633	Federring	Spring washer	Rondelle de ressort	Arandela de resorte	1,00	
38	1000222612	Scheibe	Washer	Rondelle	Disco	1,00	
39	1000109786	Schraube	Bolt	Boulon	Perno	1,00	
40	1000015345	Schraube	Bolt	Boulon	Perno	1,00	
41	1000015376	Schraube	Bolt	Boulon	Perno	1,00	
42	1000085474	Schraube	Bolt	Boulon	Perno	2,00	
43	1000048179	Schraube	Bolt	Boulon	Perno	1,00	
44	1000085471	Schraube	Bolt	Boulon	Perno	1,00	
45	1000015432	Scheibe	Washer	Rondelle	Disco	1,00	
46	1000015433	Scheibe	Washer	Rondelle	Disco	1,00	



**Motor P45 Engine P45 Moteur P45 Motor P45**

Pos.	Artikelnr.	Bezeichnung	Description	Pièce de rechange	Parte de repuesto	Menge	Ausführung:
47	1000022017	Federring	Spring washer	Rondelle de ressort	Arandela de resorte	1,00	
48	1000049000	Mutter	Nut	Écrou	Tuerca	1,00	
49	1000022016	Federring	Spring washer	Rondelle de ressort	Arandela de resorte	1,00	
50	1000015407	Mutter	Nut	Écrou	Tuerca	1,00	
51	1000223197	Schraube	Bolt	Boulon	Perno	1,00	
52	1000082491	Schraube	Bolt	Boulon	Perno	8,00	
53	1000082617	Federring	Spring washer	Rondelle de ressort	Arandela de resorte	1,00	
54	1000015347	Schraube	Bolt	Boulon	Perno	4,00	
55	1000222973	Schraube	Bolt	Boulon	Perno	4,00	
56	1000222552	Scheibe	Washer	Rondelle	Disco	2,00	
57	1000015412	Mutter	Nut	Écrou	Tuerca	2,00	
58	1000222577	Scheibe	Washer	Rondelle	Disco	1,00	
59	1000022016	Federring	Spring washer	Rondelle de ressort	Arandela de resorte	1,00	
60	1000223198	Schraube	Bolt	Boulon	Perno	1,00	
61	1000015432	Scheibe	Washer	Rondelle	Disco	1,00	



Auspuff und Luftfilter P33/34/43/45 bis 10.2002 Exhaust and air filter P33/34/43/45 up to 10.2002 Echappement et filtre à air P33/34/43/45 jusqu'à 01-2001 Escape y filtro de aire P33/34/43/45 hasta 10-2002

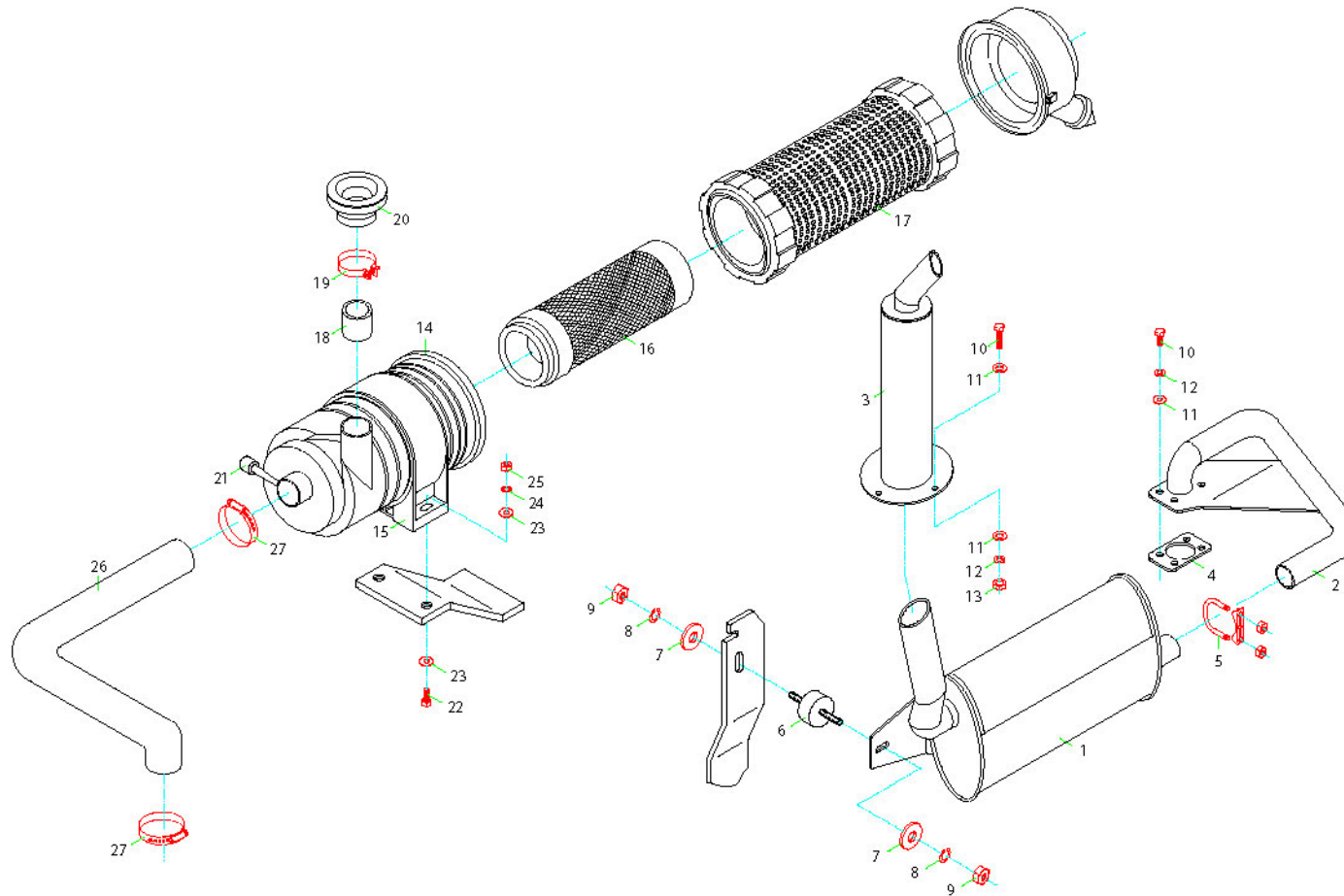

**Auspuff und Luftfilter P33/34/43/45 bis 10.2002 Exhaust and air filter P33/34/43/45 up to 10.2002 Echappement et filtre à air P33/34/43/45 jusqu'à 01-2001 Escape y filtro de aire P33/34/43/45 hasta 10-2002**

Pos.	Artikelnr.	Bezeichnung	Description	Pièce de rechange	Parte de repuesto	Menge	Ausführung:
1	1000201906	Schalldämpfer	Silencer	Silencieux	Silenciador	1	
2	1000201907	Auspuffrohr	Exhaust pipe	Tuyau d'échappement	Tubo de escape	1	P33+34
	1000201915	Auspuffrohr	Exhaust pipe	Tuyau d'échappement	Tubo de escape	1	P43
3	1000201917	Schalldämpfer	Silencer	Silencieux	Silenciador	1	
4	1000197253	Dichtung	Gasket	Garniture	Junta de estanqueidad	1	
5	1000222740	Schelle	Clamp	Attache	Abrazadera	1	
6	1000228561	Gummipuffer	Silent block	Silentbloc	Bloque silente	1	
7	1000222577	Scheibe	Washer	Rondelle	Disco	2	
8	1000022016	Federring	Spring washer	Rondelle de ressort	Arandela de resorte	2	
9	1000015407	Mutter	Nut	Écrou	Tuerca	2	
10	1000015343	Schraube	Bolt	Boulon	Perno	4	
11	1000222819	Scheibe	Washer	Rondelle	Disco	4	
12	1000082617	Federring	Spring washer	Rondelle de ressort	Arandela de resorte	4	
13	1000015406	Mutter	Nut	Écrou	Tuerca	4	
14	1000199474	Filter	Filter	Filtre	Filtro	1	
15	1000034622	Schelle	Clamp	Attache	Abrazadera	1	
16	1000231364	Filter	Filter	Filtre	Filtro	1	
17	1000231396	Filter	Filter	Filtre	Filtro	1	
18	1000216873	Stutzen	Muff	Manchon	Manguito	1	
19	1000223547	Schelle	Clamp	Attache	Abrazadera	2	
20	1000228611	Faltenbalg	Bellows	Soufflet	Fuelle	1	
21	1000031381	Unterdruckanzeige	Vacuum gauge	Manomètre à vide	Manómetro de vacío	1	
22	1000079385	Schraube	Bolt	Boulon	Perno	1	
23	1000222552	Scheibe	Washer	Rondelle	Disco	2	
24	1000082617	Federring	Spring washer	Rondelle de ressort	Arandela de resorte	2	

**Auspuff und Luftfilter P33/34/43/45 bis 10.2002 Exhaust and air filter P33/34/43/45 up to 10.2002 Echappement et filtre à air P33/34/43/45 jusqu'à 01-2001 Escape y filtro de aire P33/34/43/45 hasta 10-2002**

Pos.	Artikelnr.	Bezeichnung	Description	Pièce de rechange	Parte de repuesto	Menge	Ausführung:
25	1000015406	Mutter	Nut	Écrou	Tuerca	2	
26	1000216852	Schlauch	Hose	Boyau	Manguera	1	
27	1000223545	Schelle	Clamp	Attache	Abrazadera	2	





**WEIDEMANN**

**Weidemann 1360**

Auspuff und Luftfilter P33/P34 ab 10.2002 Exhaust and air filter P33/P34 from 10-2002 onwards Echappement et filtre à air P33/P34 de 10-2002 et au-delà Escape y filtro aire P33/P34 desde 10-2002

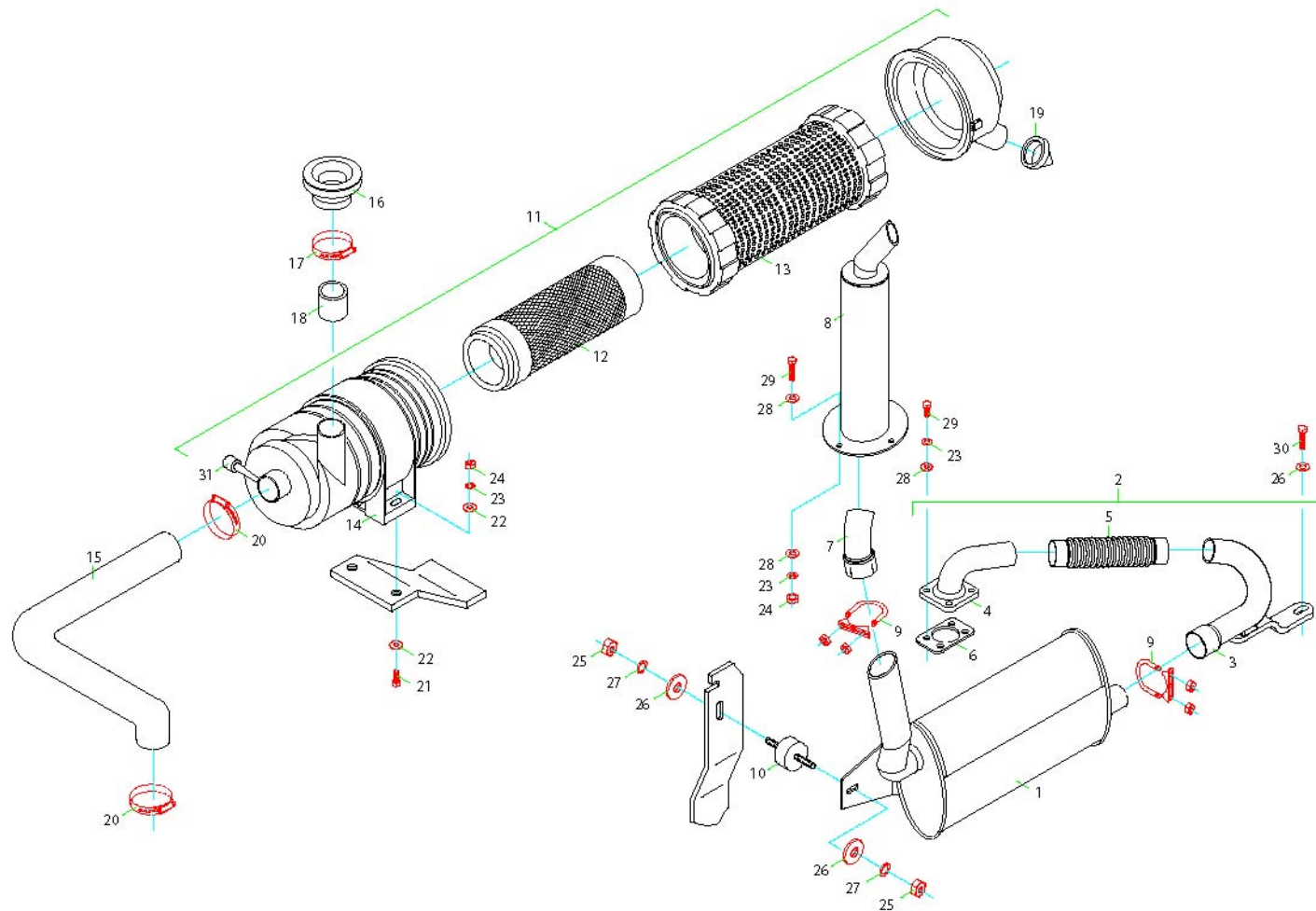

**Auspuff und Luftfilter P33/P34 ab 10.2002 Exhaust and air filter P33/P34 from 10-2002 onwards Echappement et filtre à air P33/P34 de 10-2002 et au-delà Escape y filtro aire P33/P34 desde 10-2002**

Pos.	Artikelnr.	Bezeichnung	Description	Pièce de rechange	Parte de repuesto	Menge
1	1000201906	Schalldämpfer	Silencer	Silencieux	Silenciador	1,00
2	1000205896	Auspuffrohr	Exhaust pipe	Tuyau d'échappement	Tubo de escape	1,00
3	1000205898	Auspuffrohr	Exhaust pipe	Tuyau d'échappement	Tubo de escape	1,00
4	1000205897	Auspuffrohr	Exhaust pipe	Tuyau d'échappement	Tubo de escape	1,00
5	1000205730	Rohr	Tube	Tube	Tubo	1,00
6	1000200053	Dichtung	Gasket	Garniture	Junta de estanqueidad	1,00
7	1000203503	Auspuffrohr	Exhaust pipe	Tuyau d'échappement	Tubo de escape	1,00
8	1000201917	Auspuffrohr	Exhaust pipe	Tuyau d'échappement	Tubo de escape	1,00
9	1000222740	Schelle	Clamp	Attache	Abrazadera	2,00
10	1000228561	Gummipuffer	Silent block	Silentbloc	Bloque silente	1,00
11	1000199474	Filter	Filter	Filtre	Filtro	1,00
12	1000231364	Filter	Filter	Filtre	Filtro	1,00
13	1000231396	Filter	Filter	Filtre	Filtro	1,00
14	1000034622	Schelle	Clamp	Attache	Abrazadera	1,00
15	1000216852	Schlauch	Hose	Boyau	Manguera	1,00
16	1000228611	Faltenbalg	Bellows	Soufflet	Fuelle	1,00
17	1000223546	Schelle	Clamp	Attache	Abrazadera	1,00
18	1000216873	Stutzen	Muff	Manchon	Manguito	1,00
19	1000084971	Ventil	Valve	Soupape	Válvula	1,00
20	1000223544	Schelle	Clamp	Attache	Abrazadera	2,00
21	1000079385	Schraube	Bolt	Boulon	Perno	2,00
22	1000222552	Scheibe	Washer	Rondelle	Disco	4,00
23	1000082617	Federring	Spring washer	Rondelle de ressort	Arandela de resorte	2,00
24	1000015406	Mutter	Nut	Écrou	Tuerca	2,00
25	1000015407	Mutter	Nut	Écrou	Tuerca	2,00

**Auspuff und Luftfilter P33/P34 ab 10.2002 Exhaust and air filter P33/P34 from 10-2002 onwards Echappement et filtre à air P33/P34 de 10-2002 et au-delà Escape y filtro aire P33/P34 desde 10-2002**

Pos.	Artikelnr.	Bezeichnung	Description	Pièce de rechange	Parte de repuesto	Menge
26	1000222577	Scheibe	Washer	Rondelle	Disco	2,00
27	1000022016	Federring	Spring washer	Rondelle de ressort	Arandela de resorte	2,00
28	1000222819	Scheibe	Washer	Rondelle	Disco	4,00
29	1000015343	Schraube	Bolt	Boulon	Perno	4,00
30	1000085412	Schraube	Bolt	Boulon	Perno	1,00
31	1000031381	Unterdruckanzeige	Vacuum gauge	Manomètre à vide	Manómetro de vacío	1,00



**WEIDEMANN**

**Weidemann 1360**

**-85-**

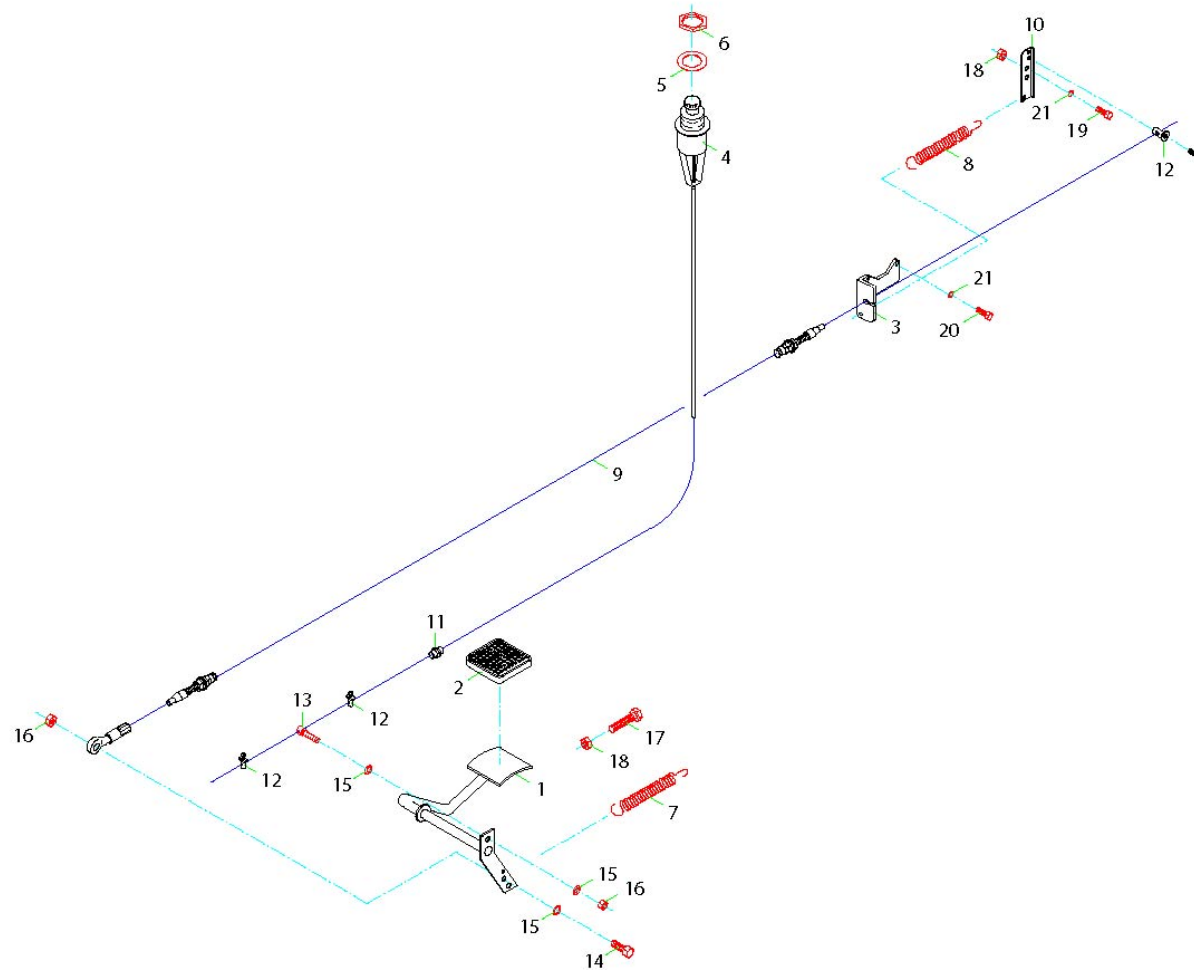

**Gasbetätigung und Drehzahlverstellung bis 10.2002 Gas control and RPM setting up to 10-2002 Contrôle de carburant et paramètres tours/min.  
jusqu'à 10-2002 Ctrol de gas y ajuste RPM hasta 10-2002**

Pos.	Artikelnr.	Bezeichnung	Description	Pièce de rechange	Parte de repuesto	Menge	Ausführung:
1	1000200418	Pedal	Pedal	Pédale	Pedal	1	
2	1000228627	Bezug	Cover	Couvercle	Cubierta	1	
3	1000200377	Halterung	Bracket	Équerre	Soporte	1	P33
	1000201412	Halterung	Bracket	Équerre	Soporte	1	P43/45
4	1000194690	Bowdenzug	Bowden cable	Câble de Bowden	Cable Bowden	1	
5	1000222950	Scheibe	Washer	Rondelle	Disco	1	
6	1000222458	Mutter	Nut	Écrou	Tuerca	1	
7	1000222932	Feder	Spring	Ressort	Resorte	1	
8	1000222925	Feder	Spring	Ressort	Resorte	1	
9	1000222594	Bowdenzug	Bowden cable	Câble de Bowden	Cable Bowden	1	
10	1000200542	Halterung	Bracket	Équerre	Soporte	1	
11	1000194700	Verschraubung	Screw coupling	Couplage fileté	Acoplamiento roscado	1	
12	1000194680	Nippel	Nipple	Raccord	Boquilla	1	
13	1000222839	Schraube	Bolt	Boulon	Perno	1	
14	1000018400	Schraube	Bolt	Boulon	Perno	1	
15	1000015430	Scheibe	Washer	Rondelle	Disco	1	
16	1000085588	Mutter	Nut	Écrou	Tuerca	1	
17	1000085392	Schraube	Bolt	Boulon	Perno	1	
18	1000015406	Mutter	Nut	Écrou	Tuerca	1	
19	1000019136	Schraube	Bolt	Boulon	Perno	1	
20	1000019593	Schraube	Bolt	Boulon	Perno	1	
21	1000222819	Scheibe	Washer	Rondelle	Disco	1	

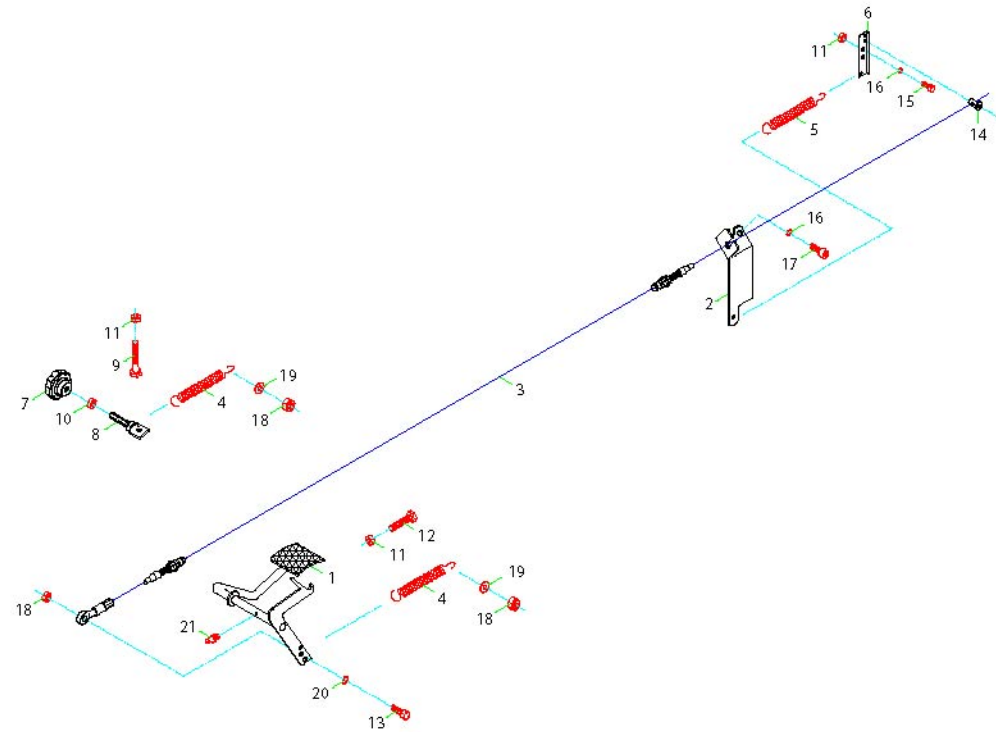



**Gasbetätigung und Drehzahlverstellung ab 10.2002 Gas control and RPM setting from 10-2002 onwards Contrôle de carburant et paramètres tours/min. de 10-2002 et au-delà Ctrol de gas y ajuste RPM desde 10-2002**

Pos.	Artikelnr.	Bezeichnung	Description	Pièce de rechange	Parte de repuesto	Menge	Ausführung:
1	1000208427	Pedal	Pedal	Pédale	Pedal	1,00	
2	1000200377	Halterung	Bracket	Équerre	Soporte	1,00	P33
	1000201412	Halterung	Bracket	Équerre	Soporte	1,00	P43/45/48
3	1000222594	Bowdenzug	Bowden cable	Câble de Bowden	Cable Bowden	1,00	
4	1000222932	Feder	Spring	Ressort	Resorte	1,00	
5	1000222925	Feder	Spring	Ressort	Resorte	1,00	
6	1000200542	Halterung	Bracket	Équerre	Soporte	1,00	
7	1000197032	Griff	Handle	Poignée	Mango	1,00	
8	1000207680	Schraube	Bolt	Boulon	Perno	1,00	
9	1000085392	Schraube	Bolt	Boulon	Perno	1,00	
10	1000015407	Mutter	Nut	Écrou	Tuerca	1,00	
11	1000015406	Mutter	Nut	Écrou	Tuerca	1,00	
12	1000085392	Schraube	Bolt	Boulon	Perno	1,00	
13	1000085384	Schraube	Bolt	Boulon	Perno	1,00	
14	1000194680	Nippel	Nipple	Raccord	Boquilla	1,00	
15	1000019136	Schraube	Bolt	Boulon	Perno	1,00	
16	1000082617	Federring	Spring washer	Rondelle de ressort	Arandela de resorte	1,00	
17	1000015343	Schraube	Bolt	Boulon	Perno	1,00	
18	1000085588	Mutter	Nut	Écrou	Tuerca	1,00	
19	1000222992	Scheibe	Washer	Rondelle	Disco	1,00	
20	1000015430	Scheibe	Washer	Rondelle	Disco	1,00	
21	1000222726	Schmiernippel	Grease nipple	Raccord graisseur	Boquilla de engrasar	1,00	

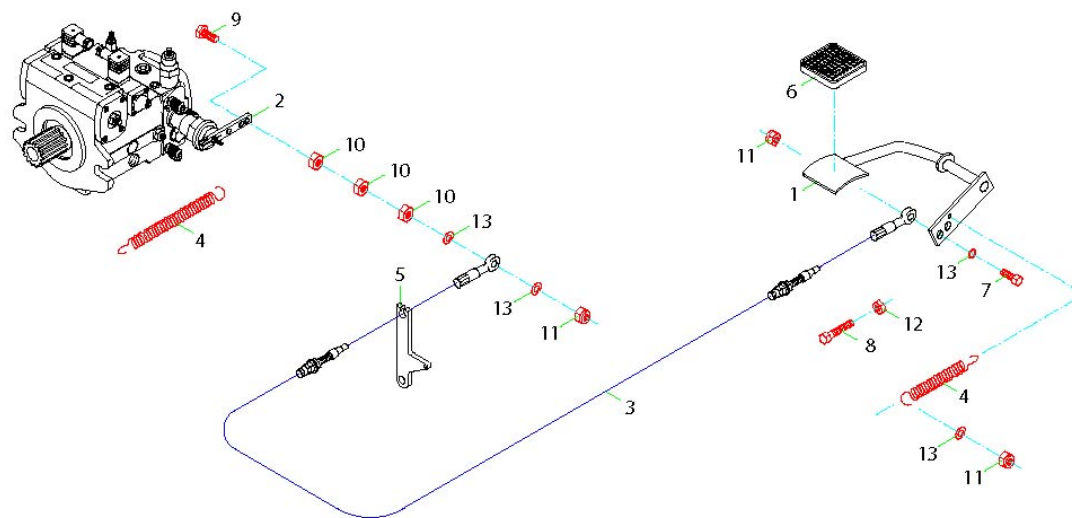

Inchbetätigung Inching operation Operation pas-à-pas Operación de marcha lenta

Pos.	Artikelnr.	Bezeichnung	Description	Pièce de rechange	Parte de repuesto	Menge
1	1000200417	Pedal	Pedal	Pédale	Pedal	1
2	1000200236	Hebel	Lever	Levier	Palanca	1
3	1000222820	Bowdenzug	Bowden cable	Câble de Bowden	Cable Bowden	1
4	1000222932	Feder	Spring	Ressort	Resorte	1
5	1000202618	Halterung	Bracket	Équerre	Soporte	1
6	1000228627	Bezug	Cover	Couvercle	Cubierta	1
7	1000085384	Schraube	Bolt	Boulon	Perno	1
8	1000085392	Schraube	Bolt	Boulon	Perno	1
9	1000085385	Schraube	Bolt	Boulon	Perno	1
10	1000015405	Mutter	Nut	Écrou	Tuerca	1
11	1000085588	Mutter	Nut	Écrou	Tuerca	1
12	1000015406	Mutter	Nut	Écrou	Tuerca	1
13	1000015430	Scheibe	Washer	Rondelle	Disco	1

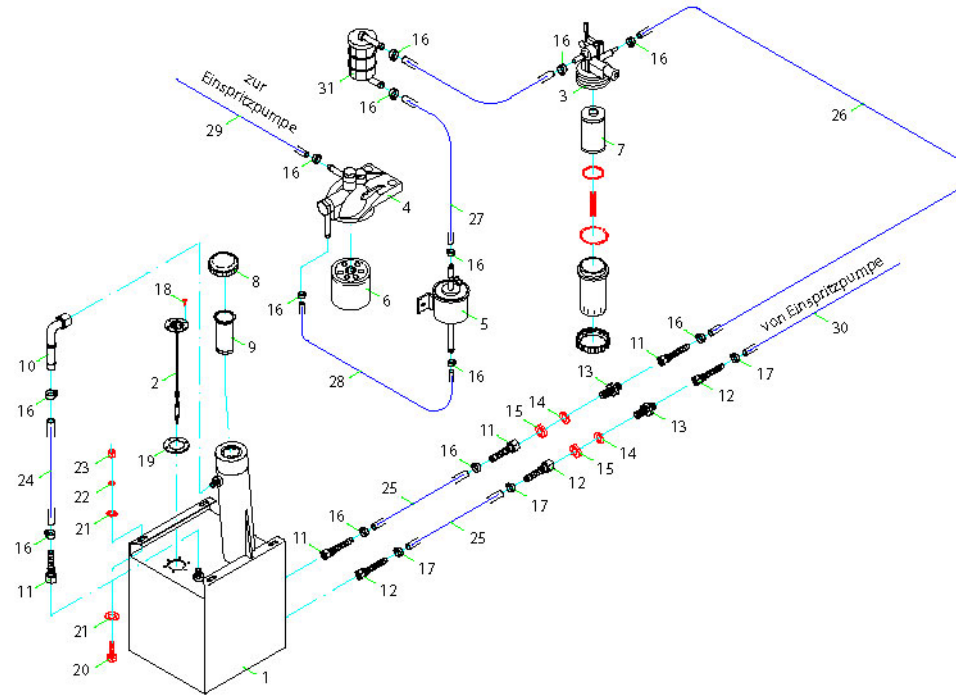

**Kraftstoffanlage bis 12.2001 Fuel system up to 12-2001 Système de carburant jusqu'à 12-2001 Sistema de combustible hasta 12-2001**

Pos.	Artikelnr.	Bezeichnung	Description	Pièce de rechange	Parte de repuesto	Menge
1	1000200426	Tank	Tank	Réservoir	Tanque	1
2	1000196814	Tankanzeige	Fuel level indicator	Indicateur de niveau de carburant	Indicador del nivel de combustible	1
3	1000199581	Filter	Filter	Filtre	Filtro	1
4	1000199751	Filter	Filter	Filtre	Filtro	1
5	1000199953	Pumpe	Pump	Pompe	Bomba	1
6	1000199319	Filter	Filter	Filtre	Filtro	1
7	1000159924	Filter	Filter	Filtre	Filtro	1
8	1000018762	Deckel	Cover	Couvercle	Cubierta	1
9	1000231548	Einsatz	Insert	Insertion	Inserto	1
10	1000114240	Verschraubung	Screw coupling	Couplage fileté	Acoplamiento roscado	1
11	1000146054	Verschraubung	Screw coupling	Couplage fileté	Acoplamiento roscado	1
12	1000226195	Verschraubung	Screw coupling	Couplage fileté	Acoplamiento roscado	1
13	1000085076	Verschraubung	Screw coupling	Couplage fileté	Acoplamiento roscado	1
14	1000082633	Federring	Spring washer	Rondelle de ressort	Arandela de resorte	1
15	1000225971	Verschraubung	Screw coupling	Couplage fileté	Acoplamiento roscado	1
16	1000222603	Schelle	Clamp	Attache	Abrazadera	1
17	1000222603	Schelle	Clamp	Attache	Abrazadera	1
18	1000048639	Schraube	Bolt	Boulon	Perno	1
19	1000225654	Dichtung	Gasket	Garniture	Junta de estanqueidad	1
20	1000079385	Schraube	Bolt	Boulon	Perno	1
21	1000222552	Scheibe	Washer	Rondelle	Disco	1
22	1000082617	Federring	Spring washer	Rondelle de ressort	Arandela de resorte	1
23	1000015406	Mutter	Nut	Écrou	Tuerca	1
24	1000216962	Schlauch	Hose	Boyau	Manguera	1
25	1000216963	Schlauch	Hose	Boyau	Manguera	1

Pos.	Artikelnr.	Bezeichnung	Description	Pièce de rechange	Parte de repuesto	Menge
26	1000216989	Schlauch	Hose	Boyau	Manguera	1
27	1000216968	Schlauch	Hose	Boyau	Manguera	1
28	1000216969	Schlauch	Hose	Boyau	Manguera	1
29	1000216982	Schlauch	Hose	Boyau	Manguera	1
30	1000216954	Schlauch	Hose	Boyau	Manguera	1
31	1000199580	Filter	Filter	Filtre	Filtro	1



**WEIDEMANN**

**Weidemann 1360**





**Kraftstoffanlage ab 12.2001 Fuel system from 12-2001 onwards Système de carburant de 12-2001 et au-delà Sistema de combustible desde 12-2001**

Pos.	Artikelnr.	Bezeichnung	Description	Pièce de rechange	Parte de repuesto	Menge
1	1000204124	Tank	Tank	Réservoir	Tanque	1,00
2	1000203457	Tankgeber	Fuel level sensor	Capteur de niveau de carburant	Sensor del nivel de sensor	1,00
3	1000231548	Einsatz	Insert	Insertion	Inserto	1,00
4	1000018762	Deckel	Cover	Couvercle	Cubierta	1,00
5	1000199580	Filter	Filter	Filtre	Filtro	1,00
6	1000087160	Filter	Filter	Filtre	Filtro	1,00
7	1000199581	Wasserabscheider	Water separator	Déshydrateur	Separador de agua	1,00
8	1000204609	Halterung	Bracket	Équerre	Soporte	1,00
9	1000197229	Filter	Filter	Filtre	Filtro	1,00
10	1000086369	Dichtung	Gasket	Garniture	Junta de estanqueidad	1,00
11	1000159924	Filter	Filter	Filtre	Filtro	1,00
12	1000224939	Ring	Ring	Anneau	Anillo	1,00
13	1000114240	Verschraubung	Screw coupling	Couplage fileté	Acoplamiento roscado	1,00
14	1000146054	Verschraubung	Screw coupling	Couplage fileté	Acoplamiento roscado	1,00
15	1000199953	Pumpe	Pump	Pompe	Bomba	1,00
16	1000079385	Schraube	Bolt	Boulon	Perno	4,00
17	1000022334	Schraube	Bolt	Boulon	Perno	1,00
18	1000015364	Schraube	Bolt	Boulon	Perno	2,00
19	1000019136	Schraube	Bolt	Boulon	Perno	2,00
20	1000020553	Schraube	Bolt	Boulon	Perno	1,00
21	1000085376	Schraube	Bolt	Boulon	Perno	6,00
22	1000222552	Scheibe	Washer	Rondelle	Disco	1,00
23	1000222819	Scheibe	Washer	Rondelle	Disco	1,00
24	1000082617	Federring	Spring washer	Rondelle de ressort	Arandela de resorte	1,00
25	1000015406	Mutter	Nut	Écrou	Tuerca	1,00

Pos.	Artikelnr.	Bezeichnung	Description	Pièce de rechange	Parte de repuesto	Menge
26	1000022016	Federring	Spring washer	Rondelle de ressort	Arandela de resorte	1,00
27	1000222577	Scheibe	Washer	Rondelle	Disco	1,00
28	1000015408	Mutter	Nut	Écrou	Tuerca	2,00
29	1000015444	Federring	Spring washer	Rondelle de ressort	Arandela de resorte	2,00
30	1000015430	Scheibe	Washer	Rondelle	Disco	2,00
31	1000222603	Schelle	Clamp	Attache	Abrazadera	2,00
32	1000216962	Schlauch	Hose	Boyau	Manguera	1,00
33	1000216990	Schlauch	Hose	Boyau	Manguera	1,00
34	1000216967	Schlauch	Hose	Boyau	Manguera	1,00
35	1000216968	Schlauch	Hose	Boyau	Manguera	1,00
36	1000216969	Schlauch	Hose	Boyau	Manguera	1,00
37	1000216982	Schlauch	Hose	Boyau	Manguera	1,00
38	1000199932	Dichtung	Gasket	Garniture	Junta de estanqueidad	1,00



**WEIDEMANN**

**Weidemann 1360**

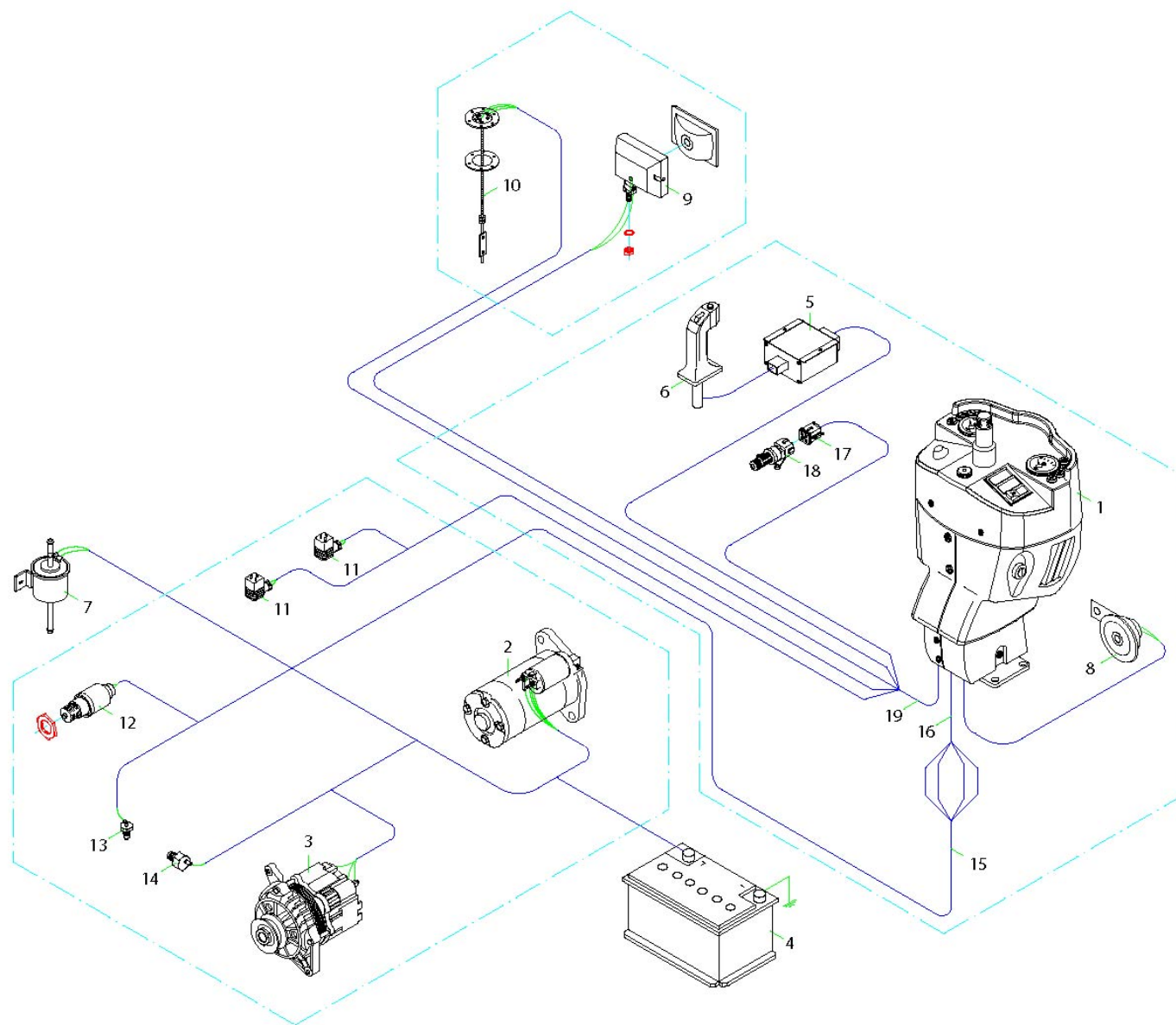

Elektrische Anlage ohne Beleuchtung | Electrical system without lighting | Système électrique sans éclairage | Sistema eléctrico sin iluminación I

Pos.	Artikelnr.	Bezeichnung	Description	Pièce de rechange	Parte de repuesto	Menge	Ausführung:
1	1000202695	Armaturenlenksäule	Steering column with instrument panel	Colonne de direction avec panneau d'instruments	Columna dirección c/ panel de instrum.	1	P33/34
	1000202696	Armaturenlenksäule	Dashboard steering column P43/48	Colonne de direction réglable du tableau de bord P43/48	Tablero Columna dirección P43/48	1	P43/48
2	1000199506	Anlasser	Starter	Démarrreur	Arrancador	1	
	1000199507	Anlasser	Starter	Démarrreur	Arrancador	1	WÜ
3	1000200170	Lichtmaschine	Dynamo	Dynamo	Dínamo	1	
	1000200171	Lichtmaschine	Dynamo	Dynamo	Dínamo	1	WÜ
4	1000193812	Batterie	Battery	Batterie	Batería	1	
5	1000200208	Steuereinheit	Control unit	Unité de contrôle	Unidad de control	1	TT
	1000202055	Steuereinheit	Control unit	Unité de contrôle	Unidad de control	1	Gessmann
6	1000200212	Hebel	Lever	Levier	Palanca	1	TT
	1000202056	Hebel	Lever	Levier	Palanca	1	Gessmann
7	1000199953	Pumpe	Pump	Pompe	Bomba	1	
8	1000156059	Hupe	Horn	Klaxon	Bocina	1	
9	1000198991	Scheinwerfer	Headlight	Projecteur	Faro	1	
	1000015293	Glühbirne	Bulb	Ampoule	Bombilla	1	
10	1000196814	Tankgeber	Fuel level sensor	Capteur de niveau de carburant	Sensor del nivel de sensor	1	bis 08.2001
	1000203457	Tankgeber	Fuel level sensor	Capteur de niveau de carburant	Sensor del nivel de sensor	1	ab 08.2001
11	1000229814	Verbindung	Connection	Connexion	Conexión	1	
12	1000199600	Magnet	Magnet	Aimant	Imán	1	
13	1000003790	Schalter	Switch	Interrupteur	Interruptor	1	oil pressure
14	1000202319	Temperaturgeber	Temperature sensor	Capteur de température	Sensor de temperatura	1	pilot lamp

**Elektrische Anlage ohne Beleuchtung | Electrical system without lighting | Système électrique sans éclairage | Sistema eléctrico sin iluminación |**

Pos.	Artikelnr.	Bezeichnung	Description	Pièce de rechange	Parte de repuesto	Menge	Ausführung:
15	1000198882	Kabelbaum	Cable harness	Faisceau de câbles	Disp. del cable de elevación	1	
16	1000202442	Kabelbaum	Cable harness	Faisceau de câbles	Disp. del cable de elevación	1	
17	1000229821	Verbindung	Connection	Connexion	Conexión	1	
18	1000206774	Schalter	Switch	Interrupteur	Interruptor	1	
19	1000198887	Kabelbaum	Cable harness	Faisceau de câbles	Disp. del cable de elevación	1	





**WEIDEMANN**

**Weidemann 1360**

**-103-**

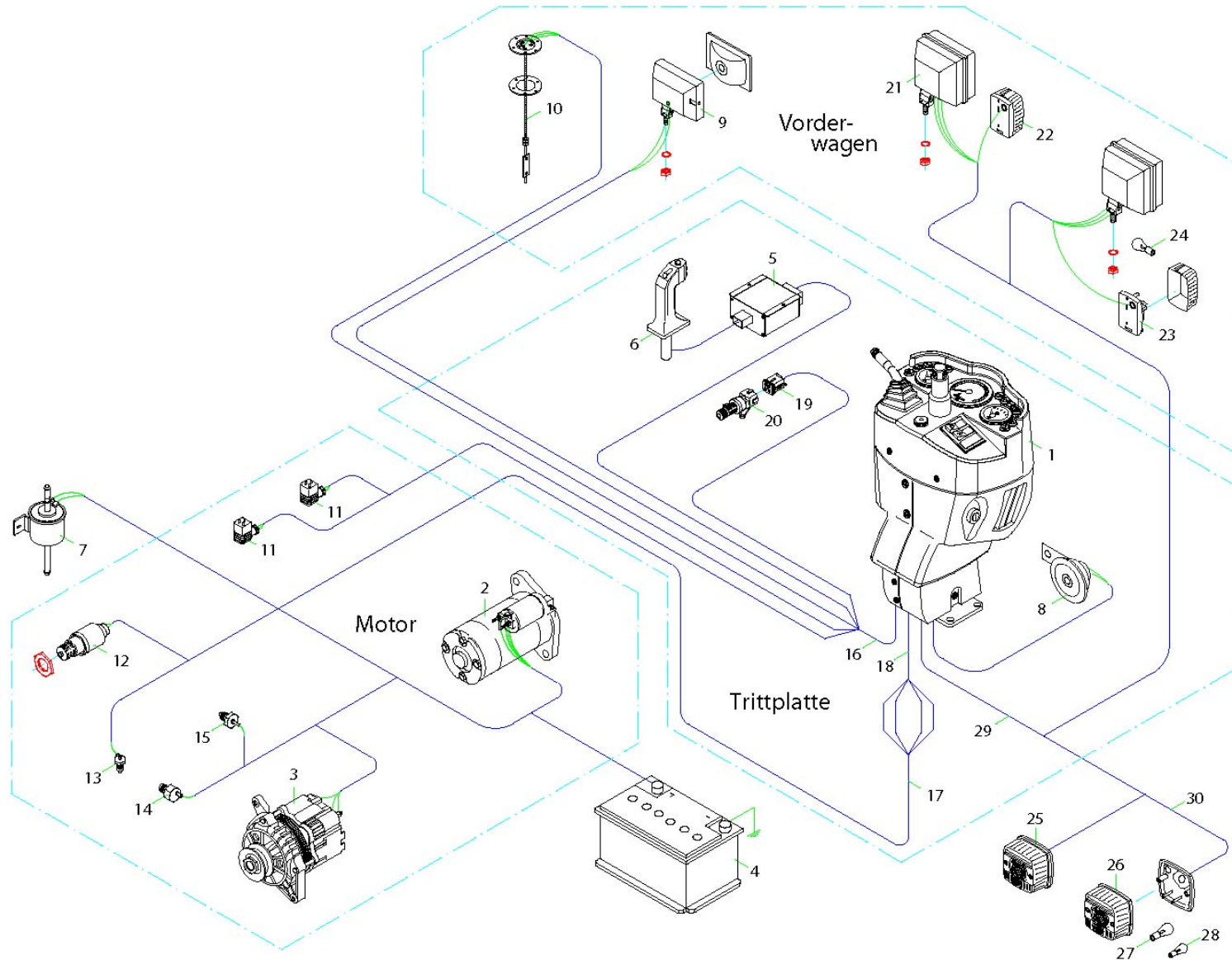



Elektrische Anlage mit Beleuchtung | Electrical system with lighting | Système électrique avec éclairage | Sistema eléctrico con iluminación I

Pos.	Artikelnr.	Bezeichnung	Description	Pièce de rechange	Parte de repuesto	Menge	Ausführung:
1	1000202695	Armaturenlenksäule	Steering column with instrument panel	Colonne de direction avec panneau d'instruments	Columna dirección c/ panel de instrum.	1	P33/34
	1000202696	Armaturenlenksäule	Steering column with instrument panel	Colonne de direction avec panneau d'instruments	Columna dirección c/ panel de instrum.	1	P43/48
2	1000199506	Anlasser	Starter	Démarrreur	Arrancador	1	
	1000199507	Anlasser	Starter	Démarrreur	Arrancador	1	WÜ
3	1000200170	Lichtmaschine	Dynamo	Dynamo	Dínamo	1	
	1000200171	Lichtmaschine	Dynamo	Dynamo	Dínamo	1	WÜ
4	1000193812	Batterie	Battery	Batterie	Batería	1	
5	1000200208	Steuereinheit	Control unit	Unité de contrôle	Unidad de control	1	TT
	1000202055	Steuereinheit	Control unit	Unité de contrôle	Unidad de control	1	Gessmann
6	1000200212	Hebel	Lever	Levier	Palanca	1	TT
	1000202056	Hebel	Lever	Levier	Palanca	1	Gessmann
7	1000199953	Pumpe	Pump	Pompe	Bomba	1	
8	1000156059	Hupe	Horn	Klaxon	Bocina	1	
9	1000198991	Scheinwerfer	Headlight	Projecteur	Faro	1	
	1000015293	Glühbirne	Bulb	Ampoule	Bombilla	1	
10	1000196814	Tankgeber	Fuel level sensor	Capteur de niveau de carburant	Sensor del nivel de sensor	1	bis 08.2001
	1000203457	Tankgeber	Fuel level sensor	Capteur de niveau de carburant	Sensor del nivel de sensor	1	ab 08.2001
11	1000229814	Verbindung	Connection	Connexion	Conexión	1	
12	1000199600	Magnet	Magnet	Aimant	Imán	1	
13	1000003790	Schalter	Switch	Interrupteur	Interruptor	1	oil pressure
14	1000202319	Temperaturgeber	Temperature sensor	Capteur de température	Sensor de temperatura	1	pilot lamp

**Elektrische Anlage mit Beleuchtung | Electrical system with lighting | Système électrique avec éclairage | Sistema eléctrico con iluminación I**

Pos.	Artikelnr.	Bezeichnung	Description	Pièce de rechange	Parte de repuesto	Menge	Ausführung:
15	1000196831	Temperaturgeber	Temperature sensor	Capteur de température	Sensor de temperatura	1	heat indicator
16	1000198887	Kabelbaum	Cable harness	Faisceau de câbles	Disp. del cable de elevación	1	
17	1000198882	Kabelbaum	Cable harness	Faisceau de câbles	Disp. del cable de elevación	1	
18	1000202442	Kabelbaum	Cable harness	Faisceau de câbles	Disp. del cable de elevación	1	
19	1000229821	Verbindung	Connection	Connexion	Conexión	1	
20	1000206774	Schalter	Switch	Interrupteur	Interruptor	1	
21	1000001509	Scheinwerfer	Headlight	Projecteur	Faro	1	
	1000193799	Scheinwerfer	Headlight	Projecteur	Faro	1	EINSATZ
	1000196701	Glühbirne	Bulb	Ampoule	Bombilla	1	15W
	1000193808	Glühbirne	Bulb	Ampoule	Bombilla	1	4W
22	1000143109	Leuchte	Light	Lampe	Luz	1	
23	1000193767	Leuchte	Light	Lampe	Luz	1	
24	1000193816	Glühbirne	Bulb	Ampoule	Bombilla	1	
25	1000193798	Leuchte	Light	Lampe	Luz	1	re.
	1000193797	Leuchte	Light	Lampe	Luz	1	i.
26	1000062307	Glas	Window	Fenêtre	Ventana	1	
27	1000193816	Glühbirne	Bulb	Ampoule	Bombilla	1	
28	1000001520	Glühbirne	Bulb	Ampoule	Bombilla	1	
29	1000198889	Kabelbaum	Cable harness	Faisceau de câbles	Disp. del cable de elevación	1	
30	1000202140	Kabelbaum	Cable harness	Faisceau de câbles	Disp. del cable de elevación	1	



**WEIDEMANN**

**Weidemann 1360**

**-107-**

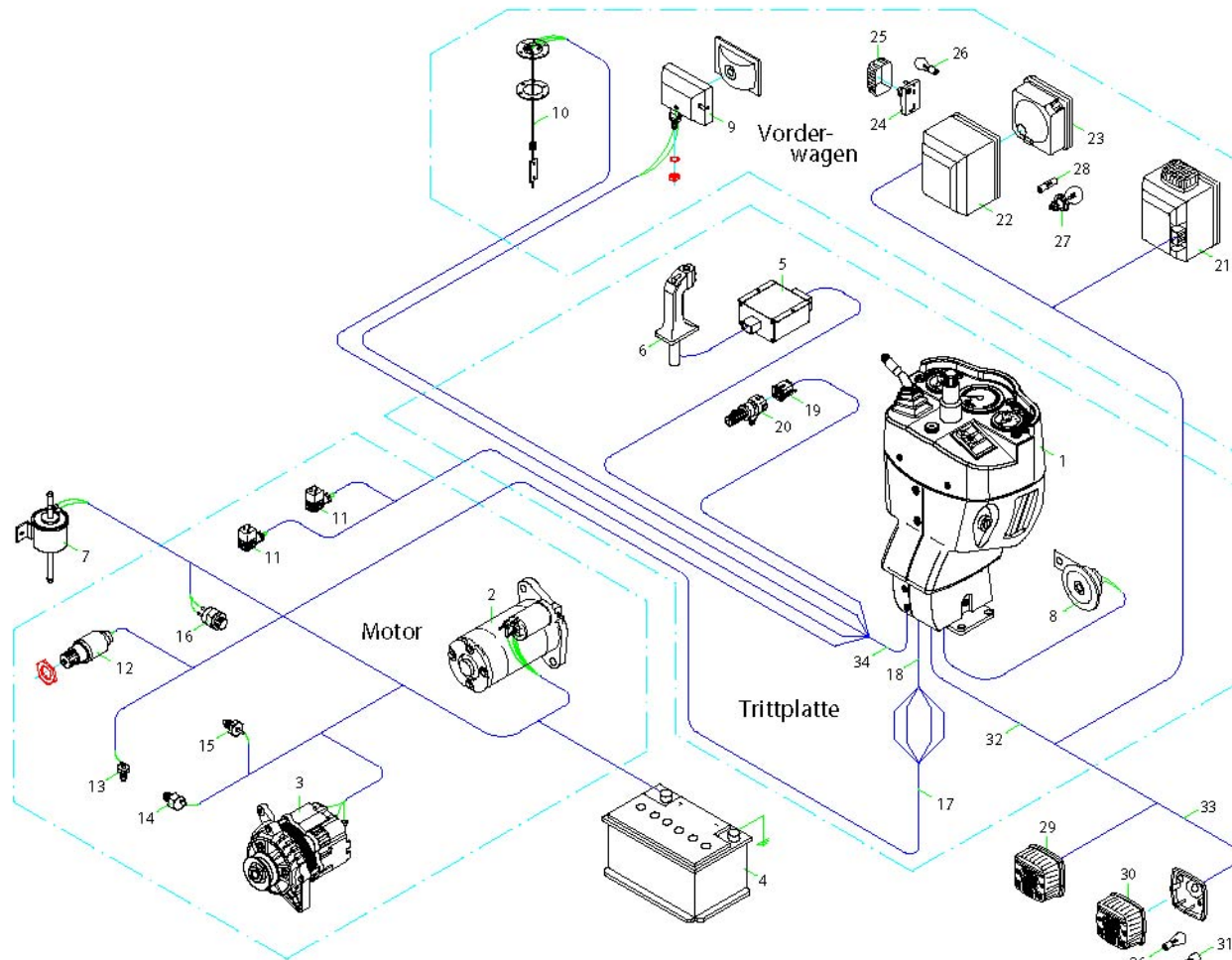

**Elektrische Anlage mit Beleuchtung II Electrical system with lighting II Système électrique avec éclairage II Sistema eléctrico con iluminación II**

Pos.	Artikelnr.	Bezeichnung	Description	Pièce de rechange	Parte de repuesto	Menge	Ausführung:
1	1000202703	Armaturenlenksäule	Steering column with instrument panel	Colonne de direction avec panneau d'instruments	Columna dirección c/ panel de instrum.	1,00	P33/34
	1000202692	Armaturenlenksäule	Steering column with instrument panel	Colonne de direction avec panneau d'instruments	Columna dirección c/ panel de instrum.	1,00	P43/48
2	1000199506	Anlasser	Starter	Démarrreur	Arrancador	1,00	
	1000199507	Anlasser	Starter	Démarrreur	Arrancador	1,00	WÜ
3	1000200170	Lichtmaschine	Dynamo	Dynamo	Dínamo	1,00	
	1000200171	Lichtmaschine	Dynamo	Dynamo	Dínamo	1,00	WÜ
4	1000193812	Batterie	Battery	Batterie	Batería	1,00	
5	1000202055	Steuereinheit	Control unit	Unité de contrôle	Unidad de control	1,00	Gessmann
6	1000204412	Hebel	Lever	Levier	Palanca	1,00	
	1000202056	Hebel	Lever	Levier	Palanca	1,00	Gessmann
7	1000199953	Pumpe	Pump	Pompe	Bomba	1,00	
8	1000156059	Hupe	Horn	Klaxon	Bocina	1,00	
9	1000198991	Scheinwerfer	Headlight	Projecteur	Faro	2,00	
	1000015293	Glühbirne	Bulb	Ampoule	Bombilla	1,00	
10	1000203457	Tankgeber	Fuel level sensor	Capteur de niveau de carburant	Sensor del nivel de sensor	1,00	
11	1000229814	Verbindung	Connection	Connexion	Conexión	1,00	
12	1000199600	Magnet	Magnet	Aimant	Imán	1,00	
13	1000204937	Schalter	Switch	Interrupteur	Interruptor	1,00	oil pressure
14	1000204938	Temperaturgeber	Temperature sensor	Capteur de température	Sensor de temperatura	1,00	pilot lamp
15	1000196831	Temperaturgeber	Temperature sensor	Capteur de température	Sensor de temperatura	1,00	heat indicator
16	1000216733	Schalter	Switch	Interrupteur	Interruptor	1,00	hydraulic oil dirt pilot lamp

**Elektrische Anlage mit Beleuchtung II Electrical system with lighting II Système électrique avec éclairage II Sistema eléctrico con iluminación II**

Pos.	Artikelnr.	Bezeichnung	Description	Pièce de rechange	Parte de repuesto	Menge	Ausführung:
17	1000198882	Kabelbaum	Cable harness	Faisceau de câbles	Disp. del cable de elevación	1,00	
18	1000207634	Kabelbaum	Cable harness	Faisceau de câbles	Disp. del cable de elevación	1,00	
19	1000229821	Verbindung	Connection	Connexion	Conexión	1,00	
20	1000206774	Schalter	Switch	Interrupteur	Interruptor	1,00	
21	1000202685	Scheinwerfer	Headlight	Projecteur	Faro	1,00	
22	1000202682	Scheinwerfer	Headlight	Projecteur	Faro	1,00	
23	1000198872	Scheinwerfer	Headlight	Projecteur	Faro	1,00	
24	1000143109	Leuchte	Light	Lampe	Luz	1,00	
25	1000193767	Leuchte	Light	Lampe	Luz	1,00	
26	1000193816	Glühbirne	Bulb	Ampoule	Bombilla	1,00	
27	1000193817	Glühbirne	Bulb	Ampoule	Bombilla	1,00	
28	1000193808	Glühbirne	Bulb	Ampoule	Bombilla	1,00	
29	1000193797	Leuchte	Light	Lampe	Luz	1,00	ji.
	1000193798	Leuchte	Light	Lampe	Luz	1,00	re.
30	1000062307	Glas	Window	Fenêtre	Ventana	1,00	
31	1000001520	Glühbirne	Bulb	Ampoule	Bombilla	1,00	
32	1000198889	Kabelbaum	Cable harness	Faisceau de câbles	Disp. del cable de elevación	1,00	
33	1000202140	Kabelbaum	Cable harness	Faisceau de câbles	Disp. del cable de elevación	1,00	
34	1000206448	Kabelbaum	Cable harness	Faisceau de câbles	Disp. del cable de elevación	1,00	



**WEIDEMANN**

**Weidemann 1360**

**-111-**

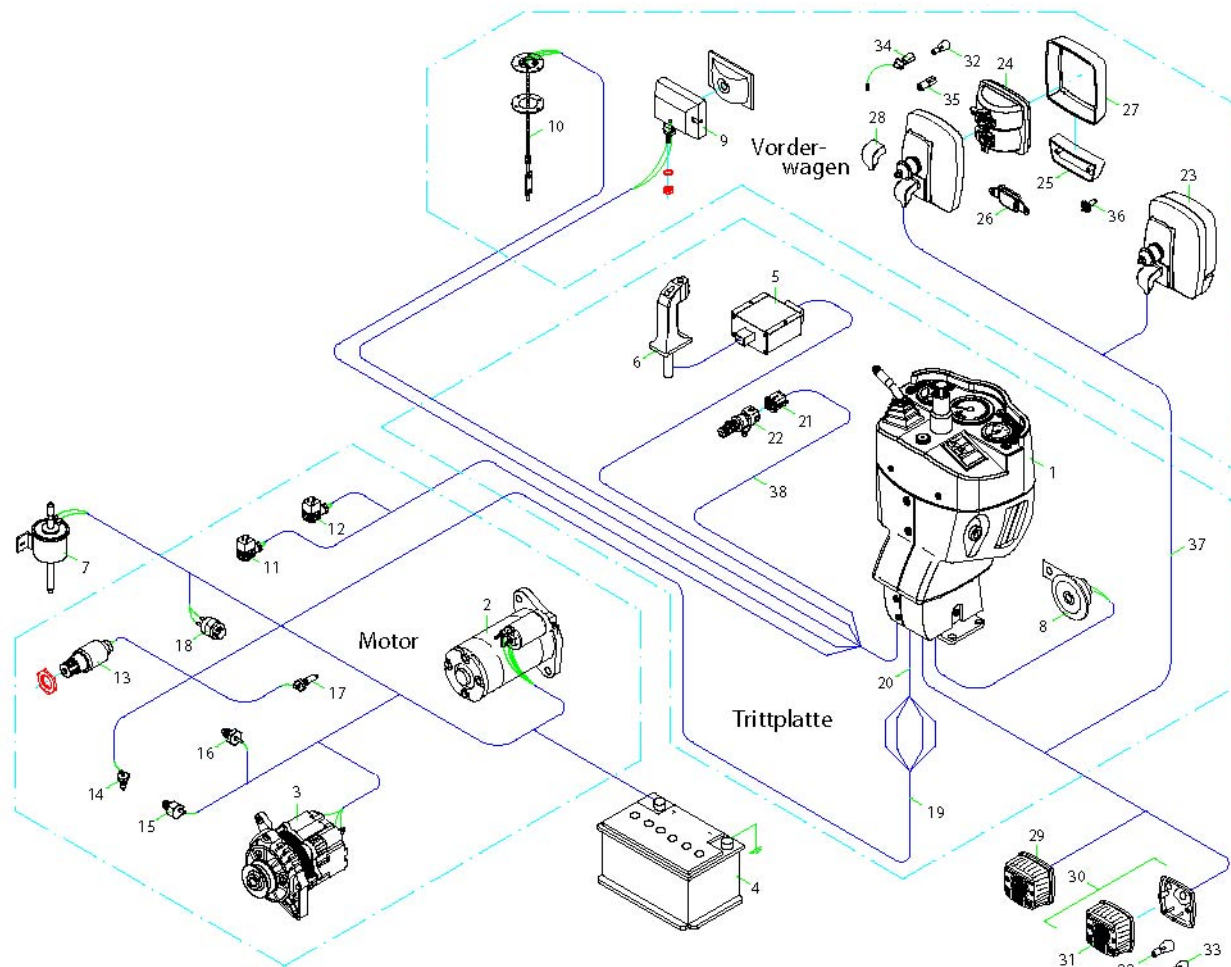



**Elektrische Anlage mit Beleuchtung III Electrical system with lighting III Système électrique avec éclairage III Sistema eléctrico con iluminación III**

Pos.	Artikelnr.	Bezeichnung	Description	Pièce de rechange	Parte de repuesto	Menge	Ausführung:
1	1000202703	Armaturenlenksäule	Steering column with instrument panel	Colonne de direction avec panneau d'instruments	Columna dirección c/ panel de instrum.	1,00	P33/34
	1000202692	Armaturenlenksäule	Steering column with instrument panel	Colonne de direction avec panneau d'instruments	Columna dirección c/ panel de instrum.	1,00	P43
2	1000199506	Anlasser	Starter	Démarrreur	Arrancador	1,00	
	1000199507	Anlasser	Starter	Démarrreur	Arrancador	1,00	WÜ
3	1000200170	Lichtmaschine	Dynamo	Dynamo	Dínamo	1,00	
	1000200171	Lichtmaschine	Dynamo	Dynamo	Dínamo	1,00	WÜ
4	1000193812	Batterie	Battery	Batterie	Batería	1,00	
5	1000202055	Hebel	Lever	Levier	Palanca	1,00	Gessmann
6	1000204412	Hebel	Lever	Levier	Palanca	1,00	
	1000202056	Hebel	Lever	Levier	Palanca	1,00	Gessmann
7	1000199953	Pumpe	Pump	Pompe	Bomba	1,00	
8	1000156059	Hupe	Horn	Klaxon	Bocina	1,00	
9	1000198991	Scheinwerfer	Headlight	Projecteur	Faro	2,00	
	1000015293	Glühbirne	Bulb	Ampoule	Bombilla	1,00	
10	1000203457	Tankgeber	Fuel level sensor	Capteur de niveau de carburant	Sensor del nivel de sensor	1,00	bis 08.2001
	1000203457	Tankgeber	Fuel level sensor	Capteur de niveau de carburant	Sensor del nivel de sensor	1,00	ab 08.2001
11	1000229814	Verbindung	Connection	Connexion	Conexión	1,00	
12	1000229814	Verbindung	Connection	Connexion	Conexión	1,00	
13	1000199600	Magnet	Magnet	Aimant	Imán	1,00	
14	1000204937	Schalter	Switch	Interrupteur	Interruptor	1,00	oil pressure
15	1000204938	Temperaturgeber	Temperature sensor	Capteur de température	Sensor de temperatura	1,00	pilot lamp

**Elektrische Anlage mit Beleuchtung III Electrical system with lighting III Système électrique avec éclairage III Sistema eléctrico con iluminación III**

Pos.	Artikelnr.	Bezeichnung	Description	Pièce de rechange	Parte de repuesto	Menge	Ausführung:
16	1000196831	Temperaturgeber	Temperature sensor	Capteur de température	Sensor de temperatura	1,00	heat indicator
17	1000165809	Temperaturgeber	Temperature sensor	Capteur de température	Sensor de temperatura	1,00	hydraulic oil
18	1000216733	Schalter	Switch	Interrupteur	Interruptor	1,00	hydraulic oil dirt pilot lamp
19	1000198882	Kabelbaum	Cable harness	Faisceau de câbles	Disp. del cable de elevación	1,00	
20	1000207634	Kabelbaum	Cable harness	Faisceau de câbles	Disp. del cable de elevación	1,00	
21	1000229821	Verbindung	Connection	Connexion	Conexión	1,00	
22	1000206774	Schalter	Switch	Interrupteur	Interruptor	1,00	
23	1000162237	Scheinwerfer	Headlight	Projecteur	Faro	1,00	
24	1000162237	Scheinwerfer	Headlight	Projecteur	Faro	1,00	
25	1000106243	Leuchte	Light	Lampe	Luz	1,00	
26	1000206706	Leuchte	Light	Lampe	Luz	1,00	
27	1000162237	Halterung	Bracket	Équerre	Soporte	1,00	
28	1000096652	Kappe	Cap	Couvercle	Tapa	1,00	
29	1000193797	Leuchte	Light	Lampe	Luz	1,00	
30	1000193798	Leuchte	Light	Lampe	Luz	1,00	
31	1000062307	Glas	Window	Fenêtre	Ventana	1,00	
32	1000193816	Glühbirne	Bulb	Ampoule	Bombilla	1,00	
33	1000001520	Glühbirne	Bulb	Ampoule	Bombilla	1,00	
34	1000015293	Glühbirne	Bulb	Ampoule	Bombilla	1,00	
35	1000193808	Glühbirne	Bulb	Ampoule	Bombilla	1,00	
36	1000109712	Glühbirne	Bulb	Ampoule	Bombilla	1,00	
37	1000202140	Kabelbaum	Cable harness	Faisceau de câbles	Disp. del cable de elevación	1,00	

**Elektrische Anlage mit Beleuchtung III Electrical system with lighting III Système électrique avec éclairage III Sistema eléctrico con iluminación III**

Pos.	Artikelnr.	Bezeichnung	Description	Pièce de rechange	Parte de repuesto	Menge	Ausführung:
38	1000206448	Kabelbaum	Cable harness	Faisceau de câbles	Disp. del cable de elevación	1,00	



Armaturenlenksäule starr WDM002 Steering column with instrument panel WDM002 Colonne de direction avec panneau d'instruments WDM002  
 Columna dirección c/ panel de instrum. WDM002

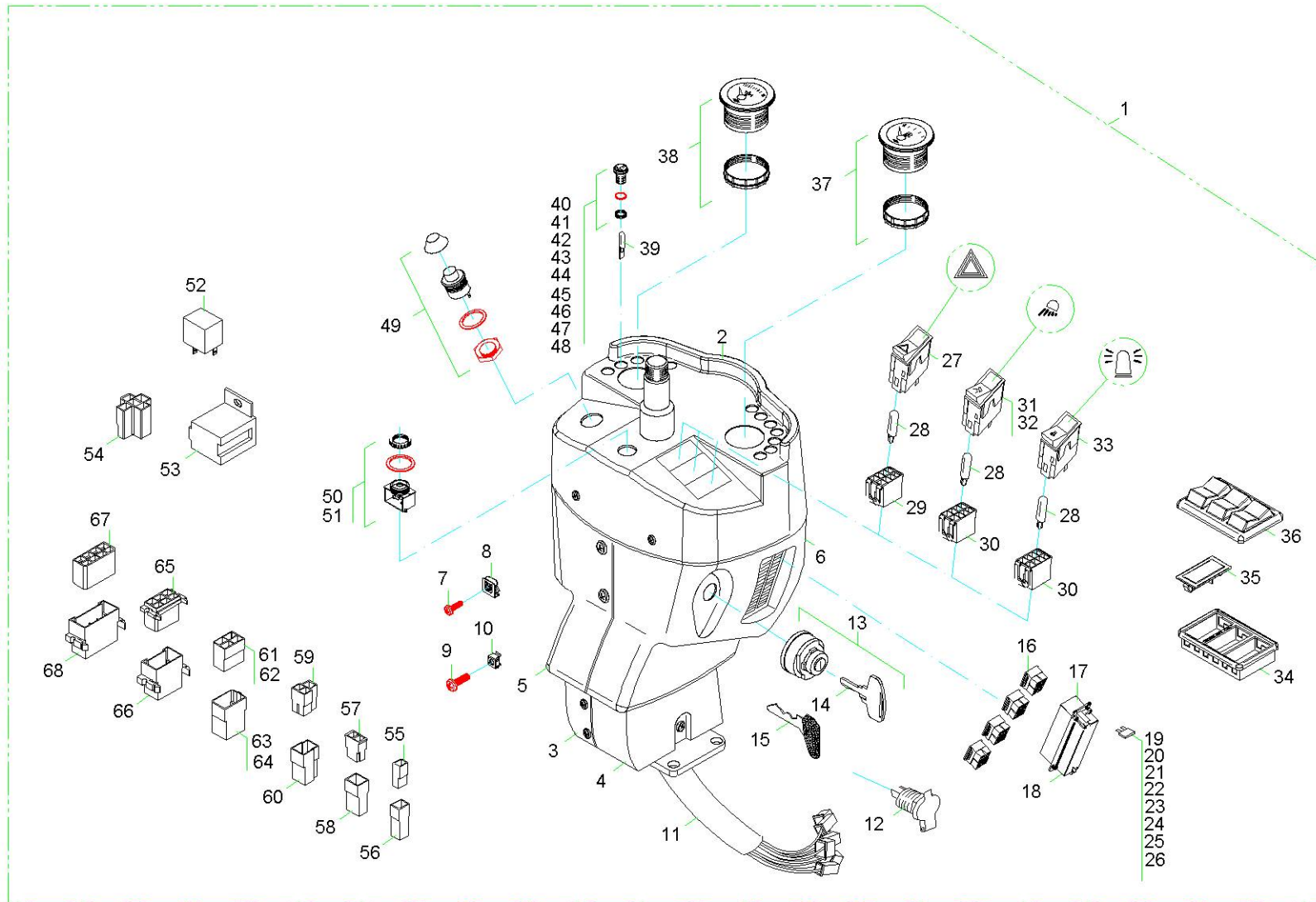

**Armaturenlenksäule starr WDM002 Steering column with instrument panel WDM002 Colonne de direction avec panneau d'instruments WDM002  
Column dirección c/ panel de instrum. WDM002**

Pos.	Artikelnr.	Bezeichnung	Description	Pièce de rechange	Parte de repuesto	Menge	Ausführung
1	1000201628	Lenksäule	steering column	arbre du volant	columna de dirección	1	
2	1000202566	Gehäuse Armaturenbrett	housing instr. Panel	boîte du tableau de bord	caja panel de instrumentos	1	
3	1000202419	Verkleidung Armaturen	trim instruments	revêtement des armatures	revestimiento de instrumentos	1	
4	1000202417	Verkleidung Armaturen	trim instruments	revêtement des armatures	revestimiento de instrumentos	1	
5	1000202572	Verkleidung Armaturen	trim instruments	revêtement des armatures	revestimiento de instrumentos	1	
6	1000202571	Verkleidung Armaturen	trim instruments	revêtement des armatures	revestimiento de instrumentos	1	
7	1000223101	Linsenschraube	ovalhead screw	vis noyée à tête bombé	tornillo de cabeza bombeada	8	
8	1000223240	Blechmutter	nut	écrou de tôle	tuerca de chapa	8	M4
9	1000048510	Flachkopfschraube	flat head screw	vis de tête plate	tornillo de cabeza plana	6	
10	1000222842	Käfigmutter	cage nut	écrou noyé	tuerca de corona	4	M6
11	1000202442	Kabelbaum Armaturen	wiring harness instruments	faisceau électrique des armatures	mazo de cables instrumentos	1	
12	1000229796	Steckdose	socket	prise de courant	caja de enchufe	1	
13	1000250556	Zündschloss	start lock	interrupteur de démarrage	cerradura de encendido	1	
14	1000250558	Zündschlüssel	ignition key	clé de contact	llave de contacto	2	without identification
15	1000199618	Zündschlüssel	ignition key	clé de contact	llave de contacto	2	No.5252
16	1000229801	Steckhülsegehäuse	plug sleeve housing	prise de connexion	caja manguito de enchufes	1	
17	1000199215	Sicherungskasten	fuse box	boîte à fusible	caja de fusibles	1	
18	1000206343	Deckel Sicherungskasten	cover fuse box	couvercle de la boîte à fusibles	tapa caja de fusibles	1	
19	1000201638	Flachsicherung	fuse	fusible	fusible	1	3:00 AM

**Armaturenlenksäule starr WDM002 Steering column with instrument panel WDM002 Colonne de direction avec panneau d'instruments WDM002  
Column dirección c/ panel de instrum. WDM002**

Pos.	Artikelnr.	Bezeichnung	Description	Pièce de rechange	Parte de repuesto	Menge	Ausführung
20	1000193785	Flachsicherung	fuse	fusible	fusible	1	5:00 AM
21	1000193786	Flachsicherung	fuse	fusible	fusible	1	7.5 A
22	1000011052	Flachsicherung	fuse	fusible	fusible	1	10:00 AM
23	1000085683	Flachsicherung	fuse	fusible	fusible	1	15 A
24	1000085684	Flachsicherung	fuse	fusible	fusible	1	20 A
25	1000193787	Flachsicherung	fuse	fusible	fusible	1	25 A
26	1000081695	Flachsicherung	fuse	fusible	fusible	1	30 A
27	1000196969	Warnblinkschalter	switch hazard warning dev.	INTERRUPTEUR DE SIGNAL DE DETRESSE	interrupteur système feux détresse	1	
28	1000198990	Glühlampe	bulb	ampoule	bombilla	3	for switch
29	1000196855	Steckhülsegehäuse	plug sleeve housing	prise de connexion	caja manguito de enchufes	1	
30	1000196854	Steckhülsegehäuse	plug sleeve housing	prise de connexion	caja manguito de enchufes	2	
31	1000215629	Schalter Arbeitsscheinwerfer	switch working light	interrupteur du réflecteur de travail	interruptor lámpara de faro	1	0-1-2
32	1000203162	Schalter Arbeitsscheinwerfer	switch working light	interrupteur du réflecteur de travail	interruptor lámpara de faro	1	0-1
33	1000196971	Kippschalter Rundumkennleuchte	switch rotating beacon	interrupteur gyrophare caractéristique	interruptor basculante faro rotatorio	1	0-1
34	1000196942	Schalterrahmen	switch frame	boîtier d'interrupteur	marco de interruptor	1	
35	1000081691	Abdeckung Schalter	switch cover	couvercle de l'interrupteur	cubierta interruptor	1	
36	1000196954	Schutzgummi	protecting rubber	caoutchouc de protection	goma de protección	1	
37	1000202443	Kraftstoffanzeige	fuel indication	indicateur à carburant	indicador de combustible	1	feul gage
38	1000196370	Betriebsstundenzähler	Working hours counter	compteur d'heures de service	contador de horas de trabajo	1	operating hours counter

**Armaturenlenksäule starr WDM002 Steering column with instrument panel WDM002 Colonne de direction avec panneau d'instruments WDM002  
Column dirección c/ panel de instrum. WDM002**

Pos.	Artikelnr.	Bezeichnung	Description	Pièce de rechange	Parte de repuesto	Menge	Ausführung
39	1000202440	Glühlampe	bulb	ampoule	bombilla	10	
40	1000202558	Kontrolleuchte	telltale	témoin	piloto de control	2	arrow
41	1000202447	Kontrolleuchte	telltale	témoin	piloto de control	1	wather temp.
42	1000202446	Kontrolleuchte	telltale	témoin	piloto de control	1	oil pressure
43	1000202445	Kontrolleuchte	telltale	témoin	piloto de control	1	alternator
44	1000202452	Kontrolleuchte	telltale	témoin	piloto de control	1	slow
45	1000202554	Kontrolleuchte	telltale	témoin	piloto de control	1	fast
46	1000202450	Kontrolleuchte	telltale	témoin	piloto de control	1	fuel
47	1000202451	Kontrolleuchte	telltale	témoin	piloto de control	1	preheat
48	1000202449	Kontrolleuchte	telltale	témoin	piloto de control	1	break
49	1000198979	Drucktaster	pressure feeler	palpeur de pression	pulsador de presión	1	
50	1000199577	Glühüberwacher	Monitoring device	Monitoring device	Dispositivo de supervisión	1	21A
51	1000199579	Glühüberwacher	Monitoring device	Monitoring device	Dispositivo de supervisión	1	28A
52	1000193779	Relais	relay	relais	relé	2	changer
53	1000193646	Halter Relais	bracket relay	support du relais	soporte relé	1	
54	1000229832	Steckhülsegehäuse	plug sleeve housing	prise de connexion	caja manguito de enchufes	1	
55	1000019456	Verbindung	connection	connexion	conexión	1	1 pole
56	1000019956	Gehäuse	housing	boîtier de connexion	caja	1	1 pole
57	1000019955	Gehäuse	housing	boîtier de connexion	caja	1	2 pole
58	1000019957	Flachsteckergehäuse	plug housing	prise de connexion	caja para enchufe plano	1	2 pole
59	1000229806	Steckhülsegehäuse	plug sleeve housing	prise de connexion	caja manguito de enchufes	1	3 pole

**Armaturenlenksäule starr WDM002 Steering column with instrument panel WDM002 Colonne de direction avec panneau d'instruments WDM002  
Column dirección c/ panel de instrum. WDM002**

Pos.	Artikelnr.	Bezeichnung	Description	Pièce de rechange	Parte de repuesto	Menge	Ausführung
60	1000229807	Flachsteckergehäuse	plug housing	prise de connexion	caja para enchufe plano	1	3 pole
61	1000229822	Steckhülsegehäuse	plug sleeve housing	prise de connexion	caja manguito de enchufes	1	4 pole (6,3X0,8)
62	1000229825	Steckhülsegehäuse	plug sleeve housing	prise de connexion	caja manguito de enchufes	1	4 pole (9,5X1,2)
63	1000229823	Flachsteckergehäuse	plug housing	prise de connexion	caja para enchufe plano	1	4 pole (6,3X0,8)
64	1000229831	Flachsteckergehäuse	plug housing	prise de connexion	caja para enchufe plano	1	4 pole (9,5X1,2)
65	1000229836	Steckhülsegehäuse	plug sleeve housing	prise de connexion	caja manguito de enchufes	1	6 pole
66	1000229837	Flachsteckergehäuse	plug housing	prise de connexion	caja para enchufe plano	1	6 pole
67	1000229845	Steckhülsegehäuse	plug sleeve housing	prise de connexion	caja manguito de enchufes	1	8 pole
68	1000229846	Flachsteckergehäuse	plug housing	prise de connexion	caja para enchufe plano	1	8 pole





**WEIDEMANN**

**Weidemann 1360**

**-121-**

# Stromlaufplan starre Lenksäule Wiring diagram right steering column Diagramme de filage colonne de direction droite Diagrama de cableado colom.direcc.derecha

**Схема электрических соединений 1360, 1370**  
 Неполная приборная панель, колонка рулевого управления

WEIDEMANN GmbH & Co.KG  
 MASCHINEN FABRIK  
 34519 Diemelsee - Flechtdorf  
 Tel.: 0563 3609-0  
 Fax: 0563 3609-6-7

Блок управления	
A:	Многофункциональный блок, автоматизация привода
Преобразователи	
B2:	Сигнальный гори
Фары	
E:	Рабочие фары
Предохранители	
F1:	Многофункциональный блок
F2:	Контрольные лампы приборной панели
F3:	Рабочие фары, звуковой сигнал
F4:	Засов, генератор, топливный насос

F6: 16 на корпусе № 12	
F6:	Штепсельный разъем
Блок питания	
G1:	Генератор
G2:	Аккумулятор (12 В)
Индикаторы и предупредительные световые сигналы	
H1:	Генератор
H2:	Температура двигателя
H3:	Запас топлива
H4:	Давление масла двигателя
H5:	Стойный тормоз
H6:	Контрольное устройство предупредительного нагрева

H7: Направление движения: вперед	
H8:	Направление движения: назад
Двигатель	
M:	Сторж
Привод	
P1:	Счетчик часов эксплуатации
P2:	Индикатор топлива
Сопротивление	
R1:	Соединительная деталь
R2:	Контрольное устройство предупредительного нагрева
R3:	Датчик уровня топлива в баке

Выключатель, Датчик	
S1:	Зажигание - пуск
S2:	Температура двигателя
S3:	Запас топлива
S4:	Давление масла двигателя
S5:	Стойный тормоз
S6:	Многофункциональный рычаг, автоматизация привода
S7:	Рабочие фары
S8:	Сигнальный гори
Соединительная деталь	
X:	Штепсельный разъем 12 В

Электромагнитный клапан	
Y1:	Топливный насос
Y2:	Засов
Y3:	Направление движения: вперед
Y4:	Направление движения: назад

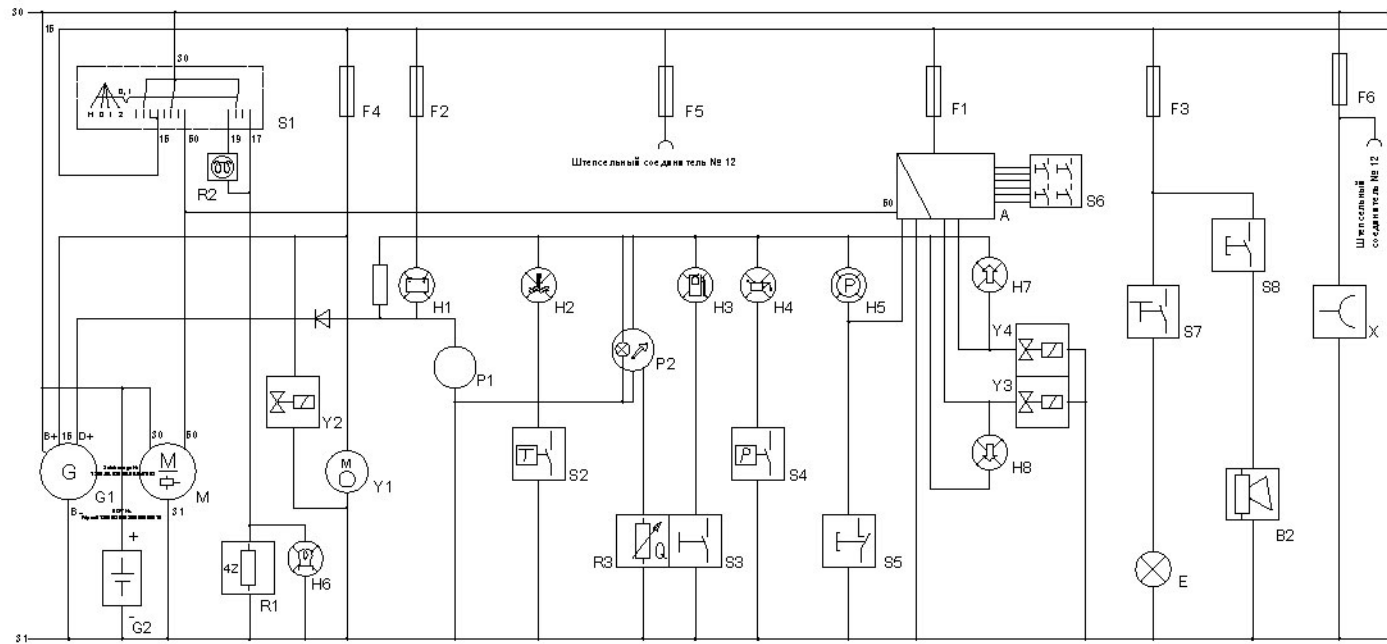

Система: 07.07.2003



**Stromlaufplan starre Lenksäule Wiring diagram right steering column Diagramme de filage colonne de direction droite Diagrama de cableado colum.direcc.derecha**

Bezeichnung	Description	Pièce de rechange	Parte de repuesto
Stromlaufplan starre Lenksäule	Wiring diagram right steering column	Diagramme de filage colonne de direction droite	Diagrama de cableado colum.direcc.derecha



Armaturenlenksäule verstellbar WDM001 Steering column with instrument panel WDM001 Colonne de direction avec panneau d'instruments WDM001  
 Columna dirección c/ panel de instrum. WDM001

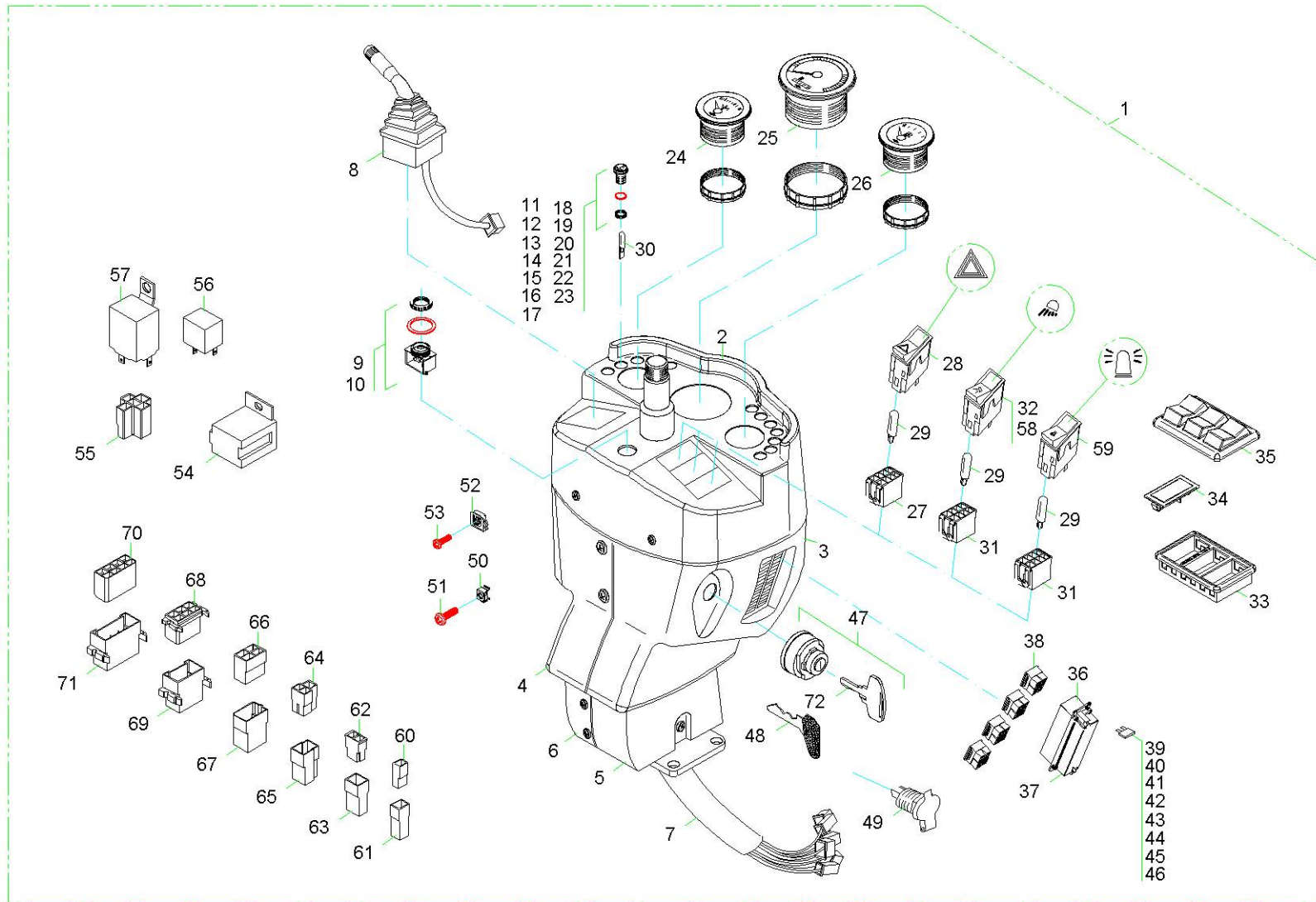

**Armaturenlenksäule verstellbar WDM001 Steering column with instrument panel WDM001 Colonne de direction avec panneau d'instruments WDM001**  
**Column dirección c/ panel de instrum. WDM001**

Pos.	Artikelnr.	Bezeichnung	Description	Pièce de rechange	Parte de repuesto	Menge	Ausführung
1	1000207430	Lenksäule	steering column	arbre du volant	columna de dirección	1	
2	1000202611	Gehäuse Armaturenbrett	housing instr. Panel	boîte du tableau de bord	caja panel de instrumentos	1	
3	1000202420	Verkleidung Armaturen	trim instruments	révêtement des armatures	revestimiento de instrumentos	1	
4	1000202418	Verkleidung Armaturen	trim instruments	révêtement des armatures	revestimiento de instrumentos	1	
5	1000202417	Verkleidung Armaturen	trim instruments	révêtement des armatures	revestimiento de instrumentos	1	
6	1000202419	Verkleidung Armaturen	trim instruments	révêtement des armatures	revestimiento de instrumentos	1	
7	1000207634	Kabelbaum Armaturen	wiring harness instruments	faisceau électrique des armatures	mazo de cables instrumentos	1	
8	1000196943	Lenkstockschalter	steeringstick switch	levier de commande directionnel	interruptor del barra de gobierno	1	
9	1000199577	Glühüberwacher	Monitoring device	Monitoring device	Dispositivo de supervisión	1	
10	1000199579	Glühüberwacher	Monitoring device	Monitoring device	Dispositivo de supervisión	1	
11	1000202558	Kontrolleuchte	telltale	témoin	piloto de control	2	arrow
12	1000202447	Kontrolleuchte	telltale	témoin	piloto de control	1	wather temp.
13	1000202446	Kontrolleuchte	telltale	témoin	piloto de control	1	oil pressure
14	1000202445	Kontrolleuchte	telltale	témoin	piloto de control	1	alternator
15	1000202448	Kontrolleuchte	telltale	témoin	piloto de control	1	Hydraulic oil dirt
16	1000202452	Kontrolleuchte	telltale	témoin	piloto de control	1	slow
17	1000202554	Kontrolleuchte	telltale	témoin	piloto de control	1	fast
18	1000202555	Kontrolleuchte	telltale	témoin	piloto de control	1	indicator
19	1000202557	Kontrolleuchte	telltale	témoin	piloto de control	1	dimmed beam
20	1000202556	Kontrolleuchte	telltale	témoin	piloto de control	1	stand lights

**Armaturenlenksäule verstellbar WDM001 Steering column with instrument panel WDM001 Colonne de direction avec panneau d'instruments WDM001**  
**Column dirección c/ panel de instrum. WDM001**

Pos.	Artikelnr.	Bezeichnung	Description	Pièce de rechange	Parte de repuesto	Menge	Ausführung
21	1000202450	Kontrolleuchte	telltale	témoin	piloto de control	1	feul
22	1000202449	Kontrolleuchte	telltale	témoin	piloto de control	1	break
23	1000202451	Kontrolleuchte	telltale	témoin	piloto de control	1	preheat
24	1000202444	Temperaturanzeige	temperature gauge	indicateur de température	indicador de la temperatura	1	heat indicator
25	1000207431	Betriebsstundenzähler	Working hours counter	compteur d'heures de service	contador de horas de trabajo	1	
26	1000202443	Kraftstoffanzeige	fuel indication	indicateur à carburant	indicador de combustible	1	fuel gage
27	1000196855	Steckhülsegehäuse	plug sleeve housing	prise de connexion	caja manguito de enchufes	1	
28	1000196969	Warnblinkschalter	switch hazard warning dev.	INTERRUPTEUR DE SIGNAL DE DETRESSE	interrupteur système feux détresse	1	
29	1000198990	Glühlampe	bulb	ampoule	bombilla	3	for switches
30	1000202440	Glühlampe	bulb	ampoule	bombilla	14	for control light
31	1000196854	Steckhülsegehäuse	plug sleeve housing	prise de connexion	caja manguito de enchufes	2	
32	1000215629	Schalter Arbeitsscheinwerfer	switch working light	interrupteur du réflecteur de travail	interruptor lámpara de faro	1	0-1-2
33	1000196942	Schalterrahmen	switch frame	boîtier d'interrupteur	marco de interruptor	1	
34	1000081691	Abdeckung Schalter	switch cover	couvercle de l'interrupteur	cubierta interruptor	1	
35	1000196954	Schutzgummi	protecting rubber	caoutchouc de protection	goma de protección	1	
36	1000199215	Sicherungskasten	fuse box	boîte à fusible	caja de fusibles	2	
37	1000206343	Deckel Sicherungskasten	cover fuse box	couvercle de la boîte à fusibles	tapa caja de fusibles	2	
38	1000229801	Steckhülsegehäuse	plug sleeve housing	prise de connexion	caja manguito de enchufes	2	

**Armaturenlenksäule verstellbar WDM001 Steering column with instrument panel WDM001 Colonne de direction avec panneau d'instruments WDM001**  
**Column dirección c/ panel de instrum. WDM001**

Pos.	Artikelnr.	Bezeichnung	Description	Pièce de rechange	Parte de repuesto	Menge	Ausführung
39	1000201638	Flachsicherung	fuse	fusible	fusible	1	3A
40	1000193785	Flachsicherung	fuse	fusible	fusible	1	5A
41	1000193786	Flachsicherung	fuse	fusible	fusible	1	7,5A
42	1000011052	Flachsicherung	fuse	fusible	fusible	1	10A
43	1000085683	Flachsicherung	fuse	fusible	fusible	1	15A
44	1000085684	Flachsicherung	fuse	fusible	fusible	1	20A
45	1000193787	Flachsicherung	fuse	fusible	fusible	1	25A
46	1000081695	Flachsicherung	fuse	fusible	fusible	1	30A
47	1000250556	Zündschloss	start lock	interrupteur de démarrage	cerradura de encendido	1	
48	1000199618	Zündschlüssel	ignition key	clé de contact	llave de contacto	1	No.5252
49	1000229796	Steckdose	socket	prise de courant	caja de enchufe	1	
50	1000222842	Käfigmutter	cage nut	écrou noyé	tuerca de corona	4	
51	1000048510	Flachkopfschraube	flat head screw	vis de tête plate	tornillo de cabeza plana	6	
52	1000223240	Blechmutter	nut	écrou de tôle	tuerca de chapa	4	
53	1000223101	Linsenschraube	ovalhead screw	vis noyée à tête bombé	tornillo de cabeza bombeada	8	
54	1000193646	Halter Relais	bracket relay	support du relais	soporte relé	1	
55	1000229832	Steckhülsegehäuse	plug sleeve housing	prise de connexion	caja manguito de enchufes	1	
56	1000193647	Relais	relay	relais	relé	1	
57	1000196806	Blinkrelais	relay	relais	relé indicador de dirección	1	
58	1000203162	Schalter Arbeitsscheinwerfer	switch working light	interrupteur du réflecteur de travail	interruptor lámpara de faro	1	0-1
59	1000196971	Kippschalter Rundumkennleuchte	switch rotating beacon	interrupteur gyrophare caractéristique	interruptor basculante faro rotatorio	1	0-1

**Armaturenlenksäule verstellbar WDM001 Steering column with instrument panel WDM001 Colonne de direction avec panneau d'instruments WDM001**  
**Column dirección c/ panel de instrum. WDM001**

Pos.	Artikelnr.	Bezeichnung	Description	Pièce de rechange	Parte de repuesto	Menge	Ausführung
60	1000019456	Verbindung	connection	connexion	conexión	1	1pole
61	1000019956	Gehäuse	housing	boîtier de connexion	caja	1	1pole
62	1000019955	Gehäuse	housing	boîtier de connexion	caja	1	2pole
63	1000019957	Flachsteckergehäuse	plug housing	prise de connexion	caja para enchufe plano	1	2pole
64	1000229806	Steckhülsegehäuse	plug sleeve housing	prise de connexion	caja manguito de enchufes	1	3pole
65	1000229807	Flachsteckergehäuse	plug housing	prise de connexion	caja para enchufe plano	1	3pole
66	1000229822	Steckhülsegehäuse	plug sleeve housing	prise de connexion	caja manguito de enchufes	1	4pole
67	1000229823	Flachsteckergehäuse	plug housing	prise de connexion	caja para enchufe plano	1	4pole
68	1000229836	Steckhülsegehäuse	plug sleeve housing	prise de connexion	caja manguito de enchufes	1	6pole
69	1000229837	Flachsteckergehäuse	plug housing	prise de connexion	caja para enchufe plano	1	6pole
70	1000229845	Steckhülsegehäuse	plug sleeve housing	prise de connexion	caja manguito de enchufes	1	8pole
71	1000229846	Flachsteckergehäuse	plug housing	prise de connexion	caja para enchufe plano	1	8pole
72	1000250558	Zündschlüssel	ignition key	clé de contact	llave de contacto	1	without identification







**WEIDEMANN**

**Weidemann 1360**

**-129-**

**Stromlaufplan verstellbare Lenksäule Wiring diagram adjustable steering column Diagramme de filage colonne de direction ajustable Diagrama de cableado colum.direcc.regul.**

**Stromlaufplan  
1360, 1370**

verstellbare Armaturenlenksäule

WEIDEMANN GmbH & Co. KG  
MASCHINENFABRIK  
34519 Diemelsee - Flechtendorf  
Tel.: 06633609-0  
Fax: 06633609-67

Steuergerät	
A:	Multibox, Fahrautomatik
Umsetzer	
B1:	Motor Temperatur
B2:	Signalhorn
Scheinwerfer	
E:	Arbeitsscheinwerfer
Sicherung	
F1:	Multibox
F2:	Kontrollleuchten, Instrumente
F3:	Arbeitsscheinwerfer

F4: Signalhorn	
F5:	Absteller, Generator, Kraftstp.
F6:	Steckanschluß
F8:	Standlicht rechts
F12:	16 an Steckgehäuse Nr 12
F7 - F11:	Beleuchtung
Stromversorgung	
G1:	Generator
G2:	Batterie (12V)
Kontroll und Wärmleuchten	
H1:	Generator
H2:	Motor Temperatur

H3: Kraftstoffreserie	
H4:	Motoröldruck
H5:	Hydraulikölverschmutzung
H6:	Feststellbremse
H7:	Vorglühuberwachung
H8:	Schnellgang
H9:	Kriechgang
H10:	Fahrtrichtung vorwärts
H11:	Fahrtrichtung rückwärts
Relais	
K1:	Entlastungsrelais 15

Motor	
M:	Starter
Instrument	
P1:	Drehzahl, Betriebsstunden
P2:	Motor Temperatur
P3:	Kraftstoff
Widerstand	
R1:	Glühfiterkerzen
R2:	Vorglühuberwacher
R3:	Kraftstofftankgeber

Schalter, Taster	
S1:	Zünd-Start
S2:	Motortemperatur
S3:	Kraftstoffreserie
S4:	Motoröldruck
S5:	Hydraulikdruck
S6:	Feststellbremse
S7:	Multihebel, Fahrautomatik
S8:	Arbeitsscheinwerfer
S9:	Beleuchtung, Blinker, Horn
Anschluß	
X:	Steckanschluß 12V

Magnetventil	
Y1:	Kraftstoffpumpe
Y2:	Absteller
Y3:	Fahrtrichtung vorwärts
Y4:	Fahrtrichtung rückwärts
Y5:	Fahrtrichtungsscanner
Y6:	Schnellgang

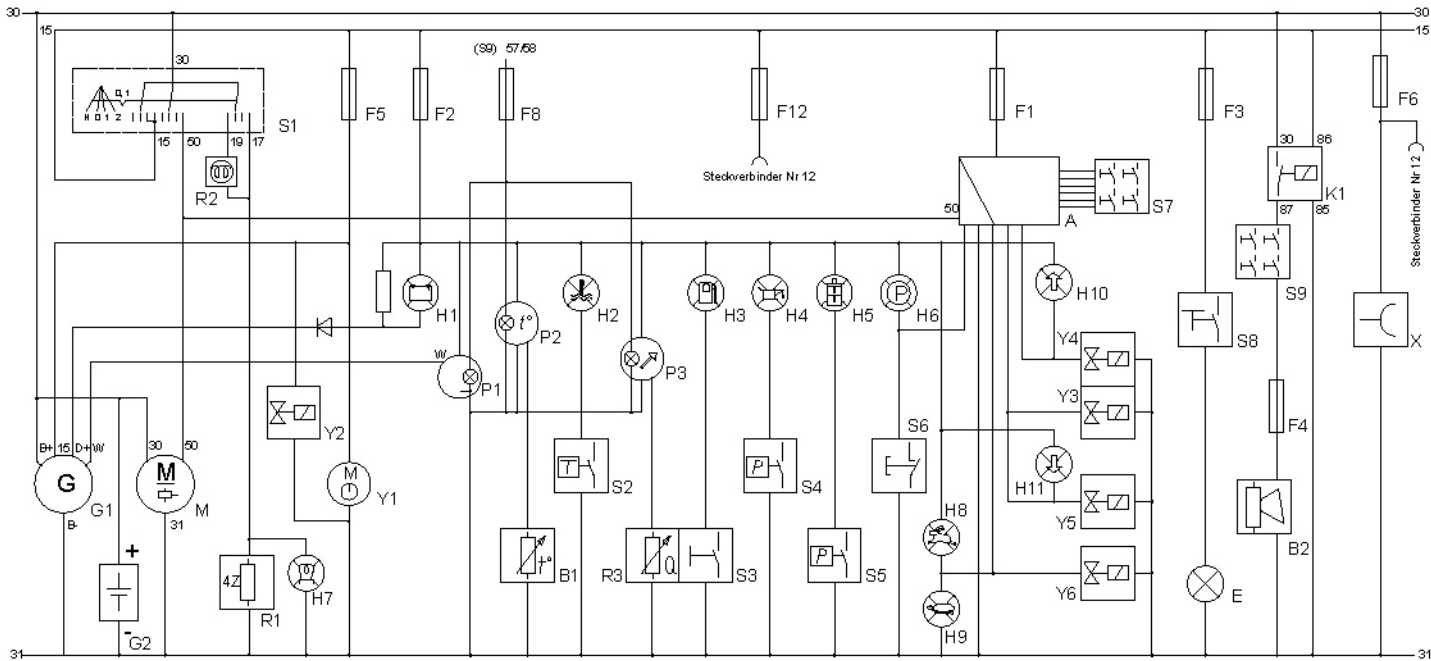

+

Stand: 07.07.2000



**Stromlaufplan verstellbare Lenksäule Wiring diagram adjustable steering column Diagramme de filage colonne de direction ajustable Diagrama de cableado colum.direcc.regul.**

Bezeichnung	Description	Pièce de rechange	Parte de repuesto
Stromlaufplan verstellbare Lenksäule	Wiring diagram adjustable steering column	Diagramme de filage colonne de direction ajustable	Diagrama de cableado colum.direcc.regul.



Схема электрических соединений 1360, 1370  
Освещение

WEIDEMANN GmbH & Co KG  
MASCHINEN FABRIK  
34519 Diemelde - Flechtendorf  
Tel.: 05633/609-0  
Fax: 05633/609-6 7

Фары
E1: Стояночный фонарь, передний левый
E2: Стояночный фонарь, задний левый
E3: Стояночный фонарь, задний правый
E4: Стояночный фонарь, передний правый
E5: Ближний свет/дальний свет, левый
E6: Ближний свет/дальний свет, правый
E7: Указатель поворота задний левый
E8: Указатель поворота передний левый
E9: Указатель поворота передний правый
E10: Указатель поворота задний правый

Предохранитель
F6: Указатель поворота 30
F7: Указатель поворота 16
F8: Стояночный фонарь, правый
F9: Стояночный фонарь, левый
F10: Ближний свет, правый/левый
F11: Дальний свет, правый/левый

Индикатор в предохранительные световые сигналы

H12: Стояночный фонарь
H13: Ближний свет
H14: Указатель поворота

Реле
K1: Обводное реле 16
K2: Реле-прерыватель указателя поворота

Выключатель, Датчик

S1: Зажигание - пуск
S9: Фонарь, указатель поворота, звуковой сигнал
S10: Предупреждающий световой сигнал

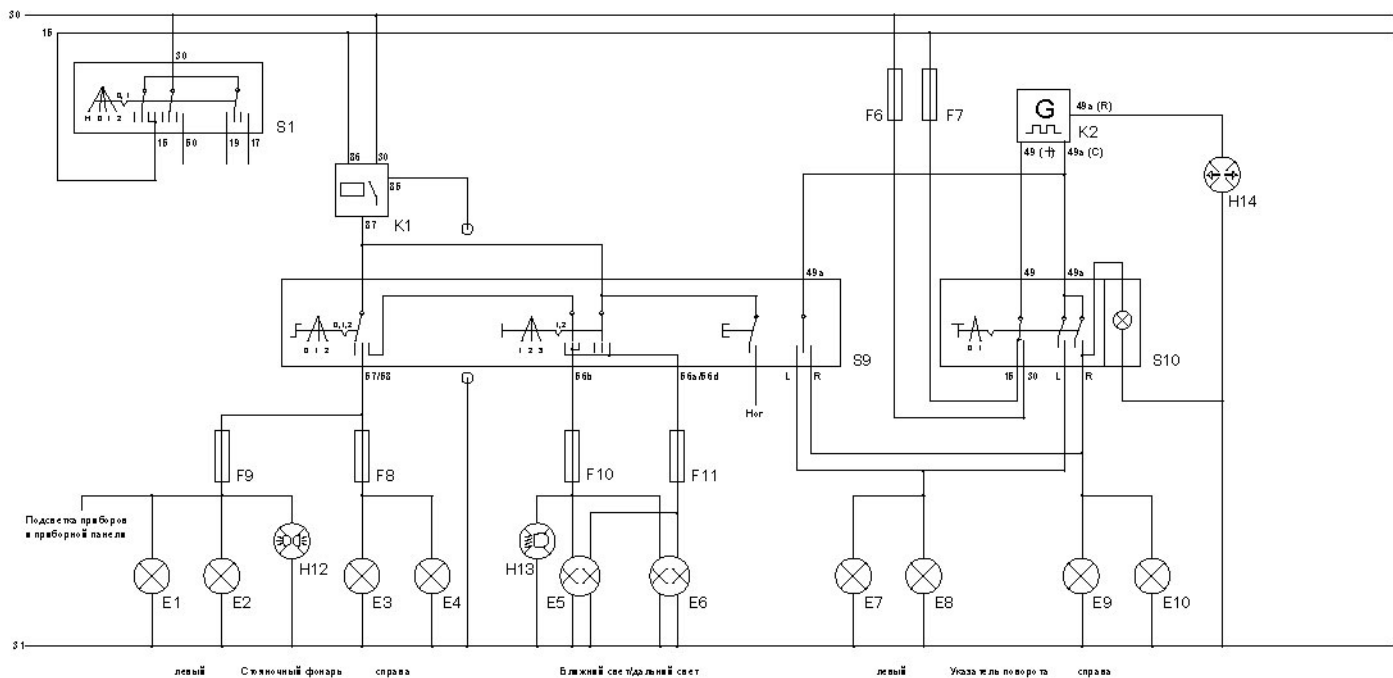

Составная\_01.07.2000

Bezeichnung	Description	Pièce de rechange	Parte de repuesto	Menge
Stromlaufplan Beleuchtung	Edge protection	Protection d'arête	Protección de los bordes	1



WEIDEMANN GmbH & Co KG  
 MASCHINENFABRIK  
 34519 Diemelsee - Flechtendorf  
 Tel.: 05633/609-0  
 Fax: 05633/609-77

Нофрас 1055 спец. / 1060 / 1360  
 Принципиальная гидравлическая схема

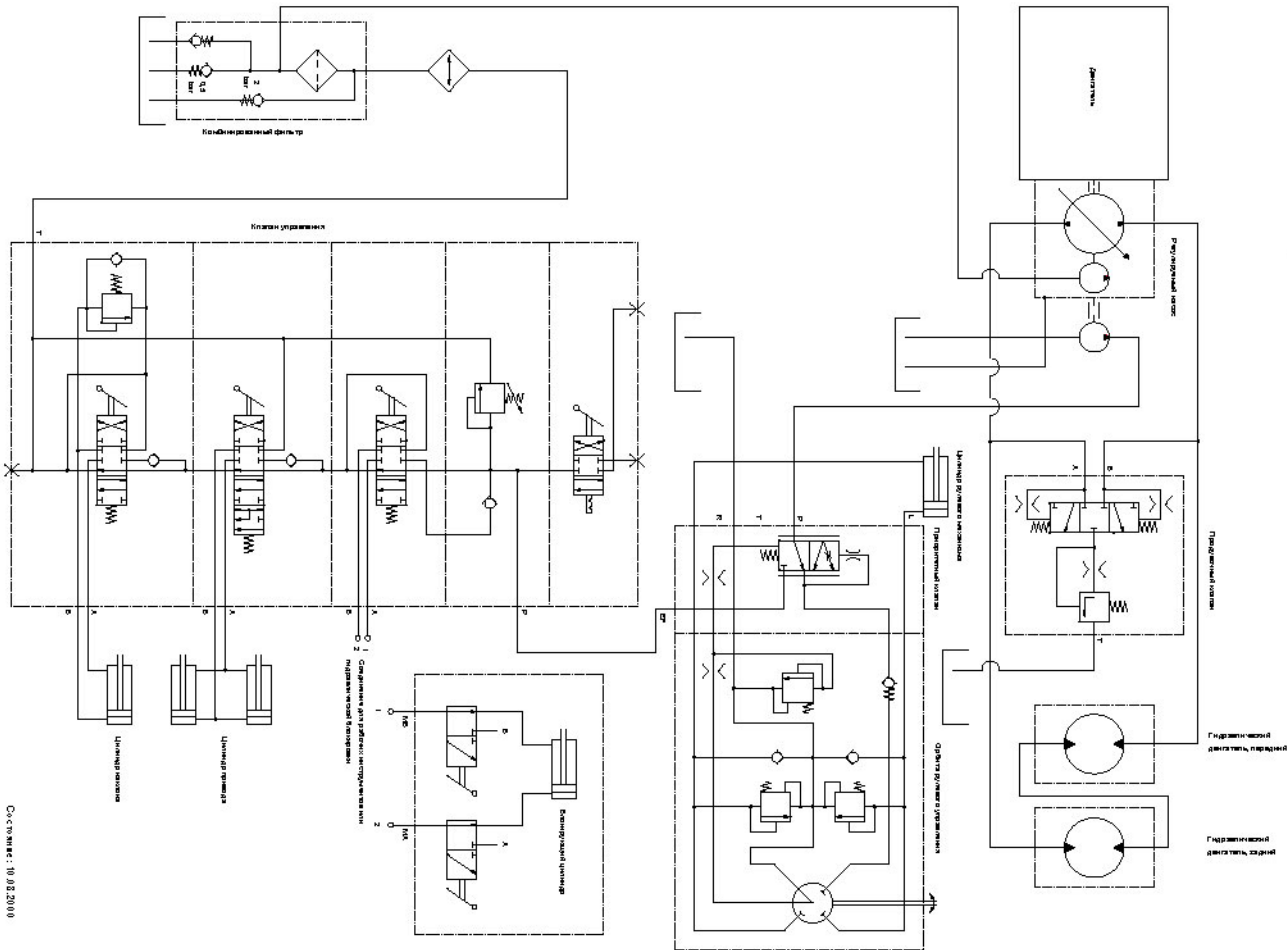

Bezeichnung	Description	Pièce de rechange	Parte de repuesto
Hydraulikschaltplan	Hydraulic circuit diagram	Diagramme de circuit hydraulique	Diagrama de circuito hidráulico



Ölpumpe Oil pump Pompe à huile Bomba de aceite

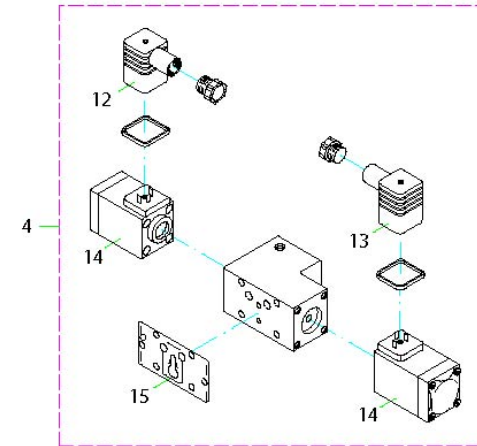
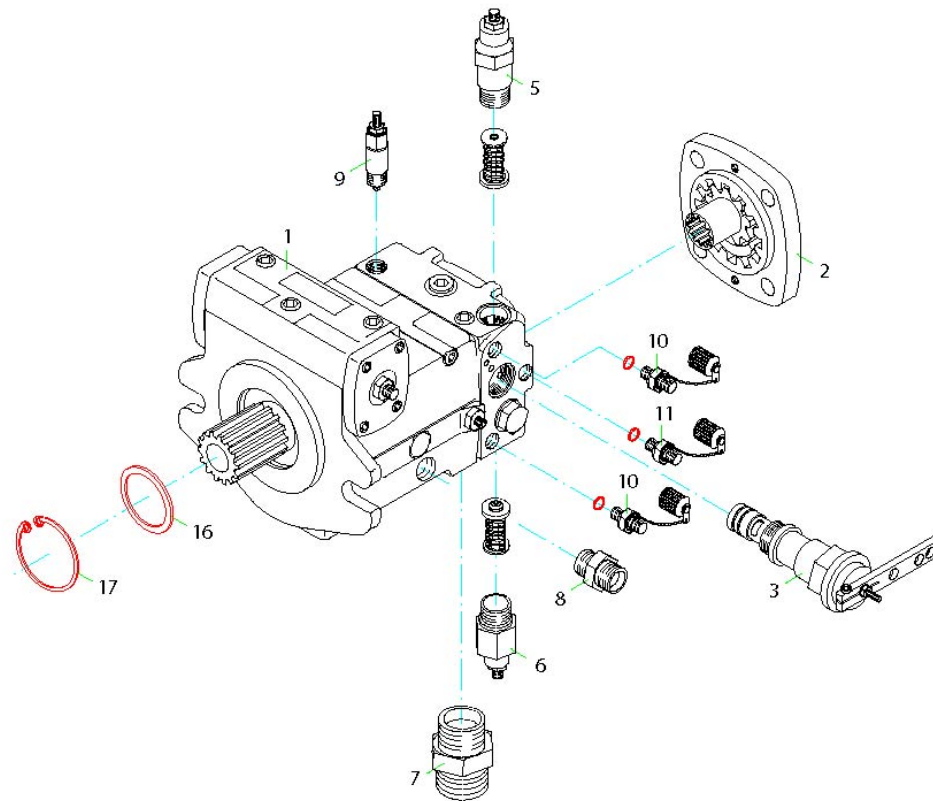



## Ölpumpe Oil pump Pompe à huile Bomba de aceite

Pos.	Artikelnr.	Bezeichnung	Description	Pièce de rechange	Parte de repuesto	Menge	Ausführung:
1	1000205858	Ölpumpe	Oil pump	Pompe à huile	Bomba de aceite	1	A10VG28DA
	1000224305	Dichtsatz	Service kit	Trousse de service	Kit de servicio	1	
2	1000226064	Pumpe	Pump	Pompe	Bomba	1	
3	1000135225	Inchpatrone	Inching valve	Soupape d'opération pas-à-pas	Válvula de marcha lenta	1	
4	1000192811	Ventil	Valve	Soupape	Válvula	1	
5	1000192703	Ventil	Valve	Soupape	Válvula	1	
6	1000192803	Ventil	Valve	Soupape	Válvula	1	
7	1000225997	Verschraubung	Screw coupling	Couplage fileté	Acoplamiento roscado	1	
8	1000226175	Verschraubung	Screw coupling	Couplage fileté	Acoplamiento roscado	1	
9	1000124065	Ventil	Valve	Soupape	Válvula	1	
10	1000226052	Verschraubung	Screw coupling	Couplage fileté	Acoplamiento roscado	1	
11	1000226043	Verschraubung	Screw coupling	Couplage fileté	Acoplamiento roscado	1	
12	1000235232	Verbindung	Connection	Connexion	Conexión	1	
13	1000235234	Verbindung	Connection	Connexion	Conexión	1	
14	1000226231	Magnet	Magnet	Aimant	Imán	1	
15	1000225430	Dichtung	Gasket	Garniture	Junta de estanqueidad	1	
16	1000098777	Wellendichtring	Sealing ring	Bague de scellement	Anillo de sellado	1	
17	1000223645	Ring	Ring	Anneau	Anillo	1	



Ölpumpe Oil pump Pompe à huile Bomba de aceite

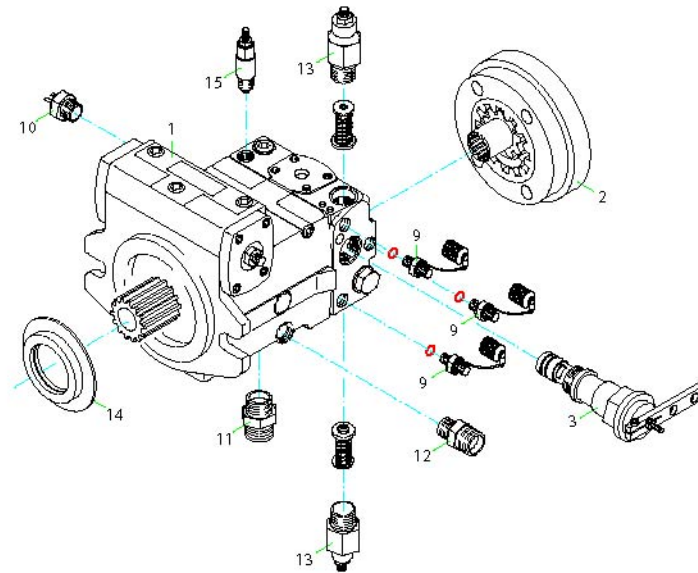
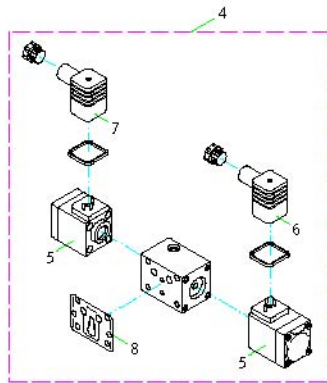

## Ölpumpe Oil pump Pompe à huile Bomba de aceite

Pos.	Artikelnr.	Bezeichnung	Description	Pièce de rechange	Parte de repuesto	Menge	Ausführung:
1	1000204448	Ölpumpe	Oil pump	Pompe à huile	Bomba de aceite	1	A 4VG40DA
	1000224302	Dichtsatz	Service kit	Trousse de service	Kit de servicio	1	
	1000224305	Dichtsatz	Service kit	Trousse de service	Kit de servicio	1	
2	1000226063	Pumpe	Pump	Pompe	Bomba	1	
3	1000226310	Inchpatrone	Inching valve	Soupape d'opération pas-à-pas	Válvula de marcha lenta	1	
4	1000192729	Ventil	Valve	Soupape	Válvula	1	
5	1000226231	Magnet	Magnet	Aimant	Imán	1	
6	1000235232	Verbindung	Connection	Connexion	Conexión	1	
7	1000235234	Verbindung	Connection	Connexion	Conexión	1	
8	1000225430	Dichtung	Gasket	Garniture	Junta de estanqueidad	1	
9	1000226052	Verschraubung	Screw coupling	Couplage fileté	Acoplamiento roscado	1	
10	1000226308	Temperaturgeber	Temperature sensor	Capteur de température	Sensor de temperatura	1	
11	1000225997	Verschraubung	Screw coupling	Couplage fileté	Acoplamiento roscado	1	
12	1000226175	Verschraubung	Screw coupling	Couplage fileté	Acoplamiento roscado	1	
13	1000165635	Ventil	Valve	Soupape	Válvula	1	
14	1000033272	Wellendichtring	Sealing ring	Bague de scellement	Anillo de sellado	1	
15	1000087816	Ventil	Valve	Soupape	Válvula	1	



Verstellpumpe Displacement pump Pompe de translation Bomba graduable

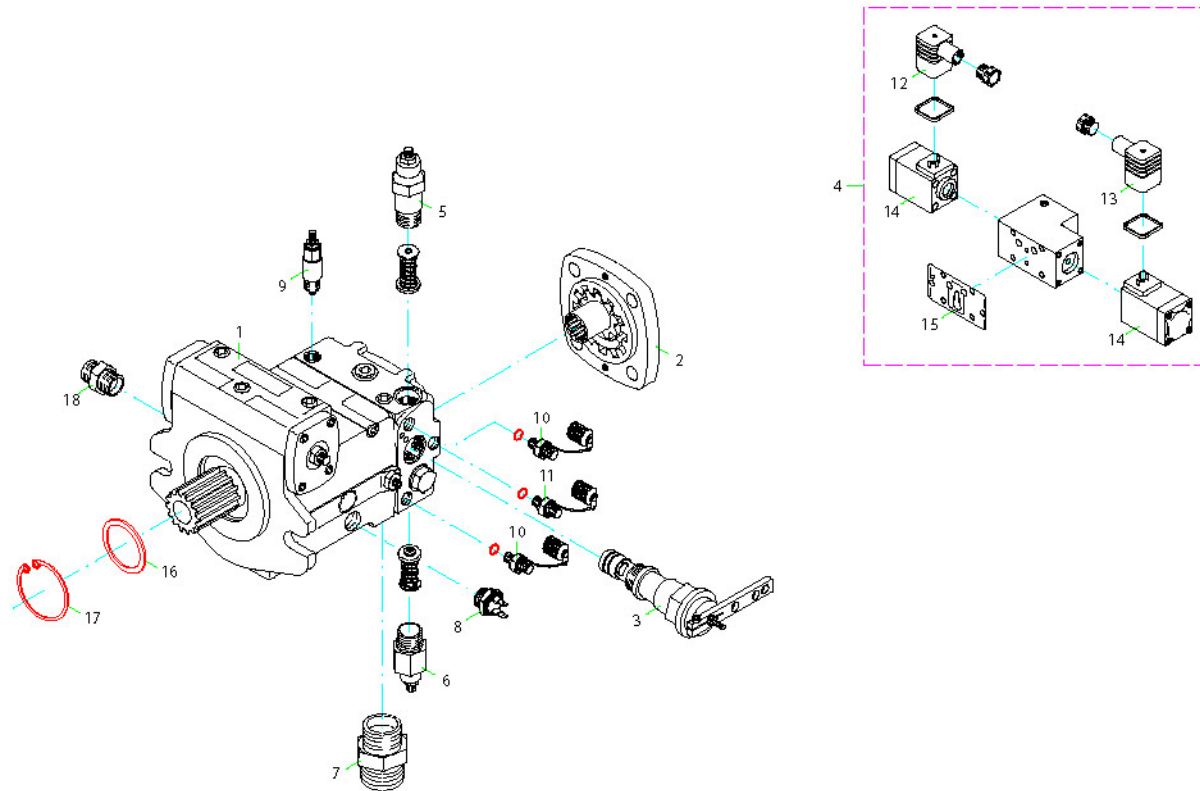

## Verstellpumpe Displacement pump Pompe de translation Bomba graduable

Pos.	Artikelnr.	Bezeichnung	Description	Pièce de rechange	Parte de repuesto	Menge
1	1000205858	Verstellpumpe	displacement pump	pompe de translation	bomba graduable	1
2	1000226064	Satz Zahnradpumpe	Pump	Pompe	Bomba	1
3	1000135225	Reglerpatrone	control cartridge	cartouche de régulateur	cartucho de control	1
4	1000124682	Wegeventil	drive valve	soupape de conduite	válvula distribuidora	1
5	1000192703	Druckbegrenzungsventil	pressure limit reliefvalve	soupape limitrice de pression	válvula de limitador de presión	1
6	1000192803	Druckbegrenzungsventil	pressure limit reliefvalve	soupape limitrice de pression	válvula de limitador de presión	1
7	1000225997	Gerade Verschraubung	screw connection	connexion à visser	atornillado directo	1
8	1000226308	Temperaturschalter	temperature switch	thermostat	interruptor de temperatura	1
9	1000124065	Abschaltventil	shut off valve	soupape de coupure	válvula de desconexión	1
10	1000226052	Messanschluss	measure connection	connexion de mesurage	conexión de medición	1
11	1000226043	Messanschluss	measure connection	connexion de mesurage	conexión de medición	1
12	1000229815	Steckhülsegehäuse	plug sleeve housing	prise de connexion	caja manguito de enchufes	1
13	1000229814	Steckhülsegehäuse	plug sleeve housing	prise de connexion	caja manguito de enchufes	1
14	1000226231	Schaltmagnet	shift solenoid	aimant de commande	electroimán de conexión	1
15	1000225423	Ventildichtung	seal	joint de soupape	junta de válvula	1
16	1000098777	Wellendichtring	shaft seal	joint spi	anillo de junta	1
17	1000223645	Sicherungsring	lock ring	circlips	anillo fijador	1
18	1000226175	Gerade Verschraubung	screw connection	connexion à visser	atornillado directo	1



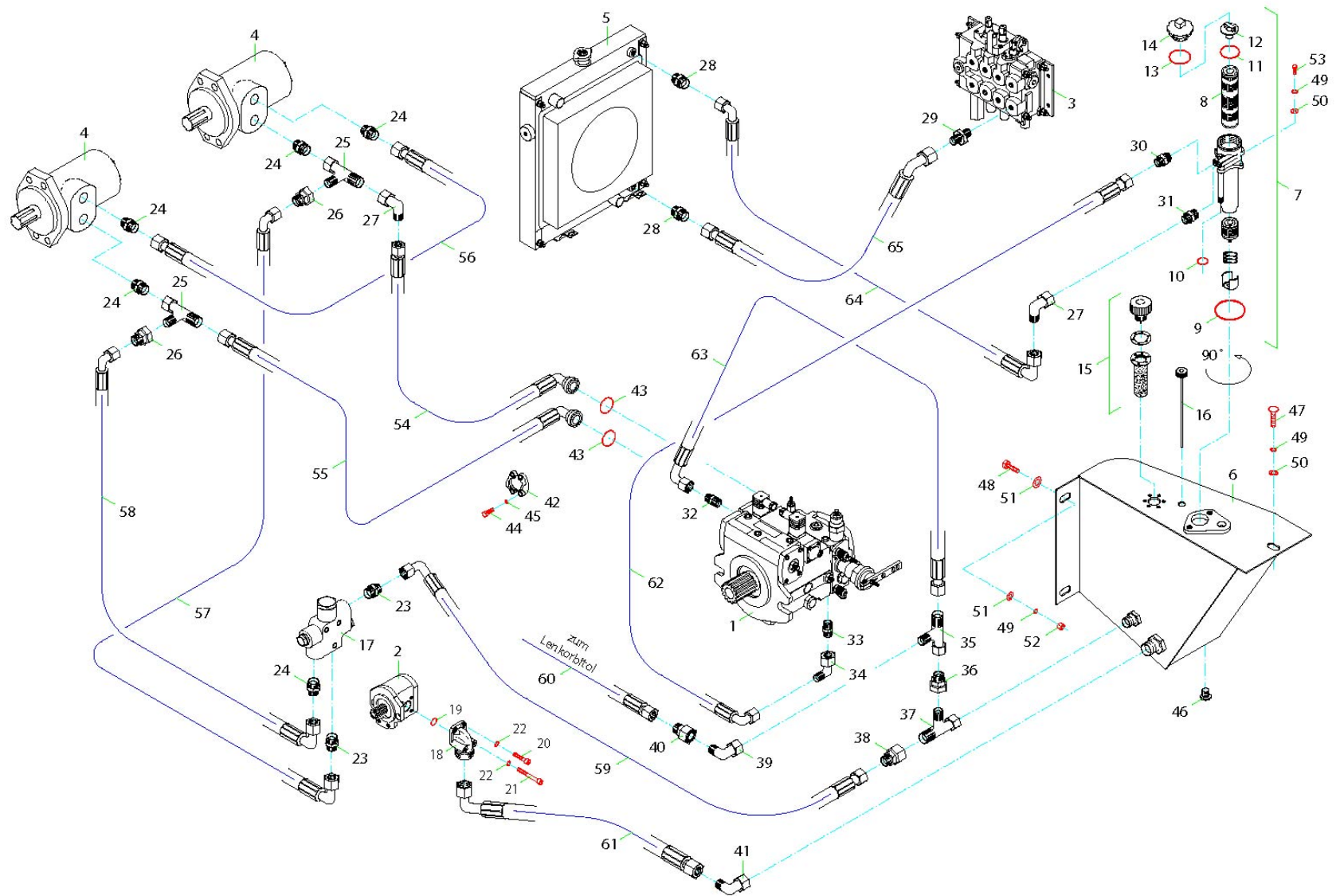

Fahrhydraulik P33 bis 10.2002 Drive hydraulics P33 up to 10-2002 Entraînement hydraulique P33 jusqu'à 10-2002 Hidráulica de accionamiento P33 hasta 10-2002

Pos.	Artikelnr.	Bezeichnung	Description	Pièce de rechange	Parte de repuesto	Menge	Ausführung:
1	1000205858	Ölpumpe	Oil pump	Pompe à huile	Bomba de aceite	1	A10VG28DA
	1000192700	Ölpumpe	Oil pump	Pompe à huile	Bomba de aceite	1	WÜ
	1000224305	Dichtsatz	Service kit	Trousse de service	Kit de servicio	1	
2	1000199130	Pumpe	Pump	Pompe	Bomba	1	
	1000224657	Dichtsatz	Service kit	Trousse de service	Kit de servicio	1	
3	1000196801	Ventil	Valve	Soupape	Válvula	1	
	1000196800	Ventil	Valve	Soupape	Válvula	1	WÜ
	1000224330	Dichtsatz	Service kit	Trousse de service	Kit de servicio	1	
4	1000200290	Ölmotor	Hydraulic motor	Moteur hydraulique	Motor hidráulico	1	
	1000201718	Ölmotor	Hydraulic motor	Moteur hydraulique	Motor hidráulico	1	WÜ
	1000225187	Dichtsatz	Service kit	Trousse de service	Kit de servicio	1	
5	1000204935	Kühler	Cooler	Refroidisseur	Enfriador	1	
	1000202681	Wasserkühler	Watercooler	Refroidisseur à eau	Refrigerante de agua	1	
	1000202386	Ölkühler	Oil cooler	Refroidisseur d'huile	Refrigerador de aceite	1	
6	1000202193	Tank	Tank	Réservoir	Tanque	1	
7	1000231529	Filter	Filter	Filtre	Filtro	1	
8	1000231365	Filter	Filter	Filtre	Filtro	1	
9	1000224909	Ring	Ring	Anneau	Anillo	1	
10	1000224858	Ring	Ring	Anneau	Anillo	1	
11	1000224914	Ring	Ring	Anneau	Anillo	1	
12	1000226496	Stutzen	Muff	Manchon	Manguito	1	
13	1000225482	Dichtung	Gasket	Garniture	Junta de estanqueidad	1	
14	1000223085	Deckel	Cover	Couvercle	Cubierta	1	
15	1000196866	Stutzen	Muff	Manchon	Manguito	1	

Fahrhydraulik P33 bis 10-2002 Drive hydraulics P33 up to 10-2002 Entraînement hydraulique P33 jusqu'à 10-2002 Hidráulica de accionamiento P33 hasta 10-2002

Pos.	Artikelnr.	Bezeichnung	Description	Pièce de rechange	Parte de repuesto	Menge	Ausführung:
16	1000225827	Ölmeßstab	Dipstick	Gauge à huile	Varilla medición de nivel	1	
17	1000226094	Ventil	Valve	Soupape	Válvula	1	
18	1000021697	Verschraubung	Screw coupling	Couplage fileté	Acoplamiento roscado	1	
19	1000224648	Ring	Ring	Anneau	Anillo	1	
20	1000048165	Schraube	Bolt	Boulon	Perno	1	
21	1000085460	Schraube	Bolt	Boulon	Perno	1	
22	1000015444	Federring	Spring washer	Rondelle de ressort	Arandela de resorte	1	
23	1000225994	Verschraubung	Screw coupling	Couplage fileté	Acoplamiento roscado	1	
24	1000225986	Verschraubung	Screw coupling	Couplage fileté	Acoplamiento roscado	1	
25	1000015517	Verschraubung	Screw coupling	Couplage fileté	Acoplamiento roscado	1	
26	1000085070	Schraube	Bolt	Boulon	Perno	1	
27	1000015513	Verschraubung	Screw coupling	Couplage fileté	Acoplamiento roscado	1	
28	1000225995	Verschraubung	Screw coupling	Couplage fileté	Acoplamiento roscado	1	
29	1000225986	Verschraubung	Screw coupling	Couplage fileté	Acoplamiento roscado	1	
30	1000225987	Verschraubung	Screw coupling	Couplage fileté	Acoplamiento roscado	1	
31	1000225995	Verschraubung	Screw coupling	Couplage fileté	Acoplamiento roscado	1	
32	1000226175	Verschraubung	Screw coupling	Couplage fileté	Acoplamiento roscado	1	
33	1000225997	Verschraubung	Screw coupling	Couplage fileté	Acoplamiento roscado	1	
34	1000020261	Verschraubung	Screw coupling	Couplage fileté	Acoplamiento roscado	1	
35	1000015539	Verschraubung	Screw coupling	Couplage fileté	Acoplamiento roscado	1	
36	1000085037	Verschraubung	Screw coupling	Couplage fileté	Acoplamiento roscado	1	
37	1000015517	Verschraubung	Screw coupling	Couplage fileté	Acoplamiento roscado	1	
38	1000085070	Verschraubung	Screw coupling	Couplage fileté	Acoplamiento roscado	1	
39	1000015512	Verschraubung	Screw coupling	Couplage fileté	Acoplamiento roscado	1	



Fahrhydraulik P33 bis 10.2002 Drive hydraulics P33 up to 10-2002 Entraînement hydraulique P33 jusqu'à 10-2002 Hidráulica de accionamiento P33 hasta 10-2002

Pos.	Artikelnr.	Bezeichnung	Description	Pièce de rechange	Parte de repuesto	Menge	Ausführung:
40	1000103420	Verschraubung	Screw coupling	Couplage fileté	Acoplamiento roscado	1	
41	1000085091	Verschraubung	Screw coupling	Couplage fileté	Acoplamiento roscado	1	
42	1000028689	Halter	Bracket	Équerre	Soporte	1	
43	1000224256	Ring	Ring	Anneau	Anillo	1	
44	1000015346	Schraube	Bolt	Boulon	Perno	1	
45	1000022016	Federring	Spring washer	Rondelle de ressort	Arandela de resorte	1	
46	1000222699	Schraube	Bolt	Boulon	Perno	1	
47	1000048576	Schraube	Bolt	Boulon	Perno	1	
48	1000015346	Schraube	Bolt	Boulon	Perno	1	
49	1000022016	Federring	Spring washer	Rondelle de ressort	Arandela de resorte	1	
50	1000015432	Scheibe	Washer	Rondelle	Disco	1	
51	1000222577	Scheibe	Washer	Rondelle	Disco	1	
52	1000015407	Mutter	Nut	Écrou	Tuerca	1	
53	1000048177	Schraube	Bolt	Boulon	Perno	1	
54	1000219019	Schlauch	Hose	Boyau	Manguera	1	
55	1000218881	Schlauch	Hose	Boyau	Manguera	1	
56	1000219023	Schlauch	Hose	Boyau	Manguera	1	
57	1000218130	Schlauch	Hose	Boyau	Manguera	1	
58	1000219096	Schlauch	Hose	Boyau	Manguera	1	
59	1000219095	Schlauch	Hose	Boyau	Manguera	1	
60	1000217380	Schlauch	Hose	Boyau	Manguera	1	
61	1000219094	Schlauch	Hose	Boyau	Manguera	1	
62	1000217929	Schlauch	Hose	Boyau	Manguera	1	
63	1000219267	Schlauch	Hose	Boyau	Manguera	1	
64	1000219188	Schlauch	Hose	Boyau	Manguera	1	

Fahrhydraulik P33 bis 10.2002 Drive hydraulics P33 up to 10-2002 Entraînement hydraulique P33 jusqu'à 10-2002 Hidráulica de accionamiento P33 hasta 10-2002

Pos.	Artikelnr.	Bezeichnung	Description	Pièce de rechange	Parte de repuesto	Menge	Ausführung:
65	1000217956	Schlauch	Hose	Boyau	Manguera	1	





**WEIDEMANN**

**Weidemann 1360**

**-147-**



Fahrhydraulik P33/34 ab 10.2002 Drive hydraulics P33/34 from 10-2002 onwards Entraînement hydraulique P33/34 de 10-2002 et au-delà Hidráulica de accionamiento P33/34 desde 10-2002

Pos.	Artikelnr.	Bezeichnung	Description	Pièce de rechange	Parte de repuesto	Menge	Ausführung:
1	1000204448	Ölpumpe	Oil pump	Pompe à huile	Bomba de aceite	1,00	A 4VG40DA
2	1000028062	Pumpe	Pump	Pompe	Bomba	1,00	
3	1000204068	Ventil	Valve	Soupape	Válvula	1,00	
	1000206204	Ventil	Valve	Soupape	Válvula	1,00	WÜ
	1000225607	Dichtsatz	Service kit	Trousse de service	Kit de servicio	1,00	
4	1000192698	Ölmotor	Hydraulic motor	Moteur hydraulique	Motor hidráulico	1,00	
	1000192699	Ölmotor	Hydraulic motor	Moteur hydraulique	Motor hidráulico	1,00	WÜ
5	1000204935	Kühler	Cooler	Refroidisseur	Enfriador	1,00	
	1000202386	Ölkühler	Oil cooler	Refroidisseur d'huile	Refrigerador de aceite	1,00	
	1000202924	Ölkühler	Oil cooler	Refroidisseur d'huile	Refrigerador de aceite	1,00	
6	1000207493	Tank	Tank	Réservoir	Tanque	1,00	
7	1000231440	Filter	Filter	Filtre	Filtro	1,00	
8	1000231365	Filter	Filter	Filtre	Filtro	1,00	
9	1000224909	Ring	Ring	Anneau	Anillo	1,00	
10	1000224858	Ring	Ring	Anneau	Anillo	1,00	
11	1000224914	Ring	Ring	Anneau	Anillo	1,00	
12	1000226496	Stutzen	Muff	Manchon	Manguito	1,00	
13	1000225482	Dichtung	Gasket	Garniture	Junta de estanqueidad	1,00	
14	1000223085	Deckel	Cover	Couvercle	Cubierta	1,00	
15	1000196866	Stutzen	Muff	Manchon	Manguito	1,00	
16	1000231370	Filter	Filter	Filtre	Filtro	1,00	
17	1000225827	Ölmeßstab	Dipstick	Gauge à huile	Varilla medición de nivel	1,00	
18	1000021697	Verschraubung	Screw coupling	Couplage fileté	Acoplamiento roscado	1,00	
19	1000224648	Ring	Ring	Anneau	Anillo	1,00	

Fahrhydraulik P33/34 ab 10.2002 Drive hydraulics P33/34 from 10-2002 onwards Entraînement hydraulique P33/34 de 10-2002 et au-delà Hidráulica de accionamiento P33/34 desde 10-2002

Pos.	Artikelnr.	Bezeichnung	Description	Pièce de rechange	Parte de repuesto	Menge	Ausführung:
20	1000048165	Schraube	Bolt	Boulon	Perno	2,00	
21	1000085460	Schraube	Bolt	Boulon	Perno	2,00	
22	1000015444	Federring	Spring washer	Rondelle de ressort	Arandela de resorte	4,00	
23	1000225995	Verschraubung	Screw coupling	Couplage fileté	Acoplamiento roscado	2,00	
24	1000225986	Verschraubung	Screw coupling	Couplage fileté	Acoplamiento roscado	1,00	
25	1000225987	Verschraubung	Screw coupling	Couplage fileté	Acoplamiento roscado	1,00	
26	1000225995	Verschraubung	Screw coupling	Couplage fileté	Acoplamiento roscado	1,00	
27	1000048177	Schraube	Bolt	Boulon	Perno	2,00	
28	1000022016	Federring	Spring washer	Rondelle de ressort	Arandela de resorte	2,00	
29	1000015432	Scheibe	Washer	Rondelle	Disco	2,00	
30	1000048576	Schraube	Bolt	Boulon	Perno	1,00	
31	1000085355	Schraube	Bolt	Boulon	Perno	1,00	
32	1000222577	Scheibe	Washer	Rondelle	Disco	1,00	
33	1000015408	Mutter	Nut	Écrou	Tuerca	1,00	
34	1000222699	Schraube	Bolt	Boulon	Perno	1,00	
35	1000225976	Verschraubung	Screw coupling	Couplage fileté	Acoplamiento roscado	1,00	
36	1000225977	Verschraubung	Screw coupling	Couplage fileté	Acoplamiento roscado	1,00	
37	1000015517	Verschraubung	Screw coupling	Couplage fileté	Acoplamiento roscado	1,00	
38	1000085037	Verschraubung	Screw coupling	Couplage fileté	Acoplamiento roscado	1,00	
39	1000015517	Verschraubung	Screw coupling	Couplage fileté	Acoplamiento roscado	1,00	
40	1000015539	Verschraubung	Screw coupling	Couplage fileté	Acoplamiento roscado	1,00	
41	1000018398	Verschraubung	Screw coupling	Couplage fileté	Acoplamiento roscado	1,00	
42	1000194721	Ventil	Valve	Soupape	Válvula	1,00	
43	1000225997	Verschraubung	Screw coupling	Couplage fileté	Acoplamiento roscado	1,00	
44	1000020261	Verschraubung	Screw coupling	Couplage fileté	Acoplamiento roscado	1,00	

Fahrhydraulik P33/34 ab 10.2002 Drive hydraulics P33/34 from 10-2002 onwards Entraînement hydraulique P33/34 de 10-2002 et au-delà Hidráulica de accionamiento P33/34 desde 10-2002

Pos.	Artikelnr.	Bezeichnung	Description	Pièce de rechange	Parte de repuesto	Menge	Ausführung:
45	1000226175	Verschraubung	Screw coupling	Couplage fileté	Acoplamiento roscado	1,00	
46	1000085108	Verschraubung	Screw coupling	Couplage fileté	Acoplamiento roscado	1,00	
47	1000015513	Verschraubung	Screw coupling	Couplage fileté	Acoplamiento roscado	1,00	
48	1000100531	Halter	Bracket	Équerre	Soporte	2,00	
49	1000028689	Halter	Bracket	Équerre	Soporte	2,00	
50	1000225273	Ring	Ring	Anneau	Anillo	2,00	
51	1000224256	Ring	Ring	Anneau	Anillo	2,00	
52	1000082242	Schraube	Bolt	Boulon	Perno	2,00	
53	1000085476	Schraube	Bolt	Boulon	Perno	2,00	
54	1000022016	Federring	Spring washer	Rondelle de ressort	Arandela de resorte	2,00	
55	1000022017	Federring	Spring washer	Rondelle de ressort	Arandela de resorte	2,00	
56	1000220117	Schlauch	Hose	Boyau	Manguera	1,00	
57	1000219172	Schlauch	Hose	Boyau	Manguera	1,00	
58	1000217908	Schlauch	Hose	Boyau	Manguera	1,00	0° / 90° 1400mm
	1000219978	Schlauch	Hose	Boyau	Manguera	1,00	0° / 90° 1300mm
59	1000220115	Schlauch	Hose	Boyau	Manguera	1,00	
60	1000220523	Schlauch	Hose	Boyau	Manguera	1,00	
61	1000220272	Schlauch	Hose	Boyau	Manguera	1,00	
62	1000220323	Schlauch	Hose	Boyau	Manguera	1,00	
63	1000217933	Schlauch	Hose	Boyau	Manguera	1,00	
64	1000220116	Schlauch	Hose	Boyau	Manguera	1,00	
65	1000220112	Schlauch	Hose	Boyau	Manguera	1,00	
66	1000219152	Schlauch	Hose	Boyau	Manguera	1,00	0° / 75° 1000mm
	1000220104	Schlauch	Hose	Boyau	Manguera	1,00	90° / 75° 850mm

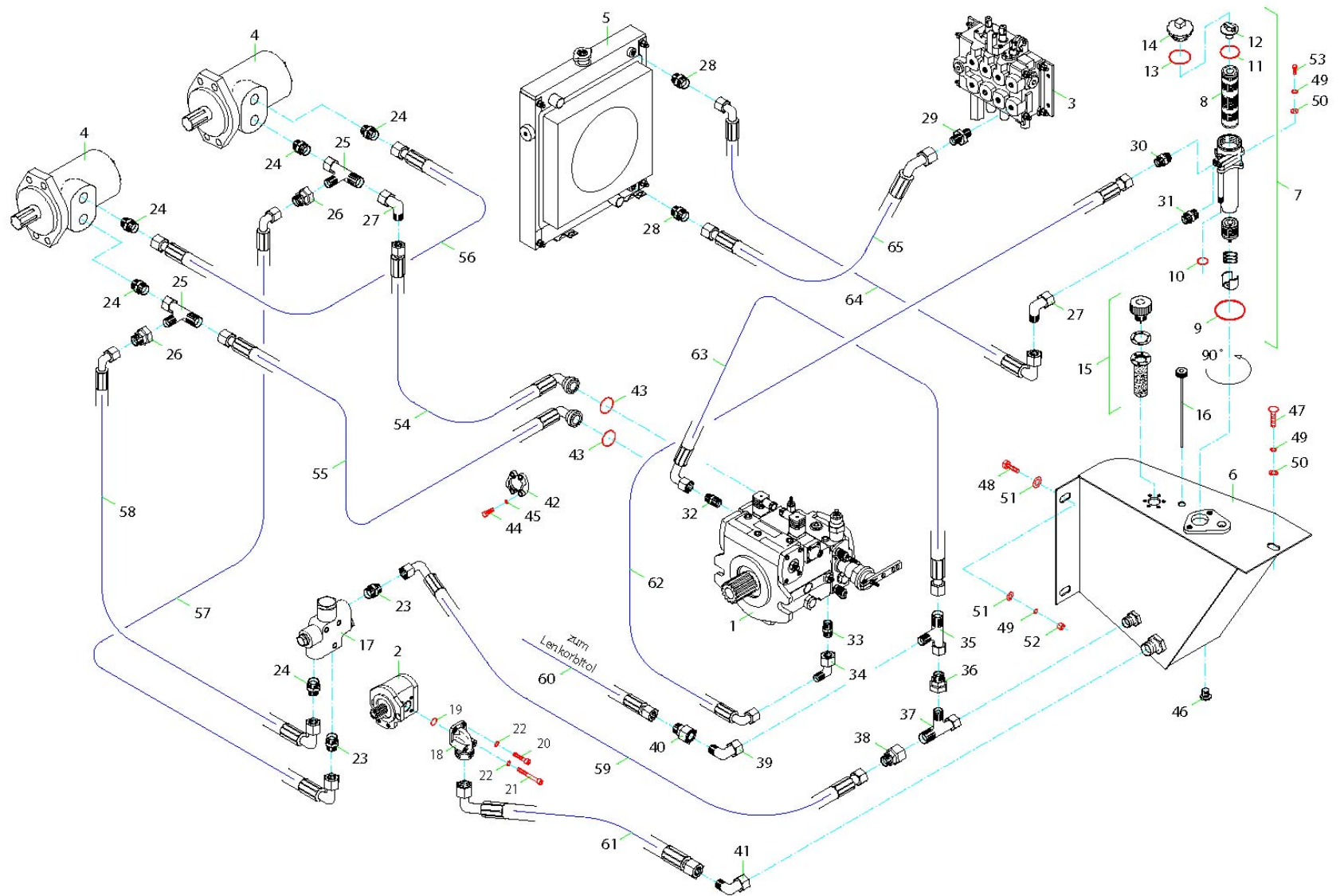



Fahrhydraulik P43 bis 10.2002 Drive hydraulics P43 up to 10-2002 Entraînement hydraulique P43 jusqu'à 10-2002 Hidráulica de accionamiento P43 hasta 10-2002

Pos.	Artikelnr.	Bezeichnung	Description	Pièce de rechange	Parte de repuesto	Menge	Ausführung:
1	1000205858	Ölpumpe	Oil pump	Pompe à huile	Bomba de aceite	1	
	1000192700	Ölpumpe	Oil pump	Pompe à huile	Bomba de aceite	1	WÜ
	1000224305	Dichtsatz	Service kit	Trousse de service	Kit de servicio	1	
2	1000199130	Pumpe	Pump	Pompe	Bomba	1	
	1000224657	Dichtsatz	Service kit	Trousse de service	Kit de servicio	1	
3	1000196801	Ventil	Valve	Soupape	Válvula	1	
	1000196800	Ventil	Valve	Soupape	Válvula	1	WÜ
	1000224330	Dichtsatz	Service kit	Trousse de service	Kit de servicio	1	
4	1000200290	Ölmotor	Hydraulic motor	Moteur hydraulique	Motor hidráulico	1	
	1000201718	Ölmotor	Hydraulic motor	Moteur hydraulique	Motor hidráulico	1	WÜ
	1000225187	Dichtsatz	Service kit	Trousse de service	Kit de servicio	1	
5	1000204935	Kühler	Cooler	Refroidisseur	Enfriador	1	
6	1000202193	Tank	Tank	Réservoir	Tanque	1	
7	1000231529	Filter	Filter	Filtre	Filtro	1	
8	1000231365	Filter	Filter	Filtre	Filtro	1	
9	1000224909	Ring	Ring	Anneau	Anillo	1	
10	1000224858	Ring	Ring	Anneau	Anillo	1	
11	1000224914	Ring	Ring	Anneau	Anillo	1	
12	1000226496	Stutzen	Muff	Manchon	Manguito	1	
13	1000225482	Dichtung	Gasket	Garniture	Junta de estanqueidad	1	
14	1000223085	Deckel	Cover	Couvercle	Cubierta	1	
15	1000196866	Stutzen	Muff	Manchon	Manguito	1	
16	1000225827	Ölmeßstab	Dipstick	Gauge à huile	Varilla medición de nivel	1	
17	1000226094	Ventil	Valve	Soupape	Válvula	1	

Fahrhydraulik P43 bis 10.2002 Drive hydraulics P43 up to 10-2002 Entraînement hydraulique P43 jusqu'à 10-2002 Hidráulica de accionamiento P43 hasta 10-2002

Pos.	Artikelnr.	Bezeichnung	Description	Pièce de rechange	Parte de repuesto	Menge	Ausführung:
18	1000021697	Verschraubung	Screw coupling	Couplage fileté	Acoplamiento roscado	1	
19	1000224648	Ring	Ring	Anneau	Anillo	1	
20	1000048165	Schraube	Bolt	Boulon	Perno	1	
21	1000085460	Schraube	Bolt	Boulon	Perno	1	
22	1000015444	Federring	Spring washer	Rondelle de ressort	Arandela de resorte	1	
23	1000225994	Verschraubung	Screw coupling	Couplage fileté	Acoplamiento roscado	1	
24	1000225986	Verschraubung	Screw coupling	Couplage fileté	Acoplamiento roscado	1	
25	1000015517	Verschraubung	Screw coupling	Couplage fileté	Acoplamiento roscado	1	
26	1000085070	Schraube	Bolt	Boulon	Perno	1	
27	1000015513	Verschraubung	Screw coupling	Couplage fileté	Acoplamiento roscado	1	
28	1000225995	Verschraubung	Screw coupling	Couplage fileté	Acoplamiento roscado	1	
29	1000225986	Verschraubung	Screw coupling	Couplage fileté	Acoplamiento roscado	1	
30	1000225987	Verschraubung	Screw coupling	Couplage fileté	Acoplamiento roscado	1	
31	1000225995	Verschraubung	Screw coupling	Couplage fileté	Acoplamiento roscado	1	
32	1000226175	Verschraubung	Screw coupling	Couplage fileté	Acoplamiento roscado	1	
33	1000225997	Verschraubung	Screw coupling	Couplage fileté	Acoplamiento roscado	1	
34	1000020261	Verschraubung	Screw coupling	Couplage fileté	Acoplamiento roscado	1	
35	1000015539	Verschraubung	Screw coupling	Couplage fileté	Acoplamiento roscado	1	
36	1000085037	Verschraubung	Screw coupling	Couplage fileté	Acoplamiento roscado	1	
37	1000015517	Verschraubung	Screw coupling	Couplage fileté	Acoplamiento roscado	1	
38	1000085070	Verschraubung	Screw coupling	Couplage fileté	Acoplamiento roscado	1	
39	1000015512	Verschraubung	Screw coupling	Couplage fileté	Acoplamiento roscado	1	
40	1000103420	Verschraubung	Screw coupling	Couplage fileté	Acoplamiento roscado	1	
41	1000085091	Verschraubung	Screw coupling	Couplage fileté	Acoplamiento roscado	1	
42	1000028689	Halter	Bracket	Équerre	Soporte	1	

Fahrhydraulik P43 bis 10.2002 Drive hydraulics P43 up to 10-2002 Entraînement hydraulique P43 jusqu'à 10-2002 Hidráulica de accionamiento P43 hasta 10-2002

Pos.	Artikelnr.	Bezeichnung	Description	Pièce de rechange	Parte de repuesto	Menge	Ausführung:
43	1000224256	Ring	Ring	Anneau	Anillo	1	
44	1000015346	Schraube	Bolt	Boulon	Perno	1	
45	1000022016	Federring	Spring washer	Rondelle de ressort	Arandela de resorte	1	
46	1000222699	Schraube	Bolt	Boulon	Perno	1	
47	1000048576	Schraube	Bolt	Boulon	Perno	1	
48	1000015346	Schraube	Bolt	Boulon	Perno	1	
49	1000022016	Federring	Spring washer	Rondelle de ressort	Arandela de resorte	1	
50	1000015432	Scheibe	Washer	Rondelle	Disco	1	
51	1000222577	Scheibe	Washer	Rondelle	Disco	1	
52	1000015407	Mutter	Nut	Écrou	Tuerca	1	
53	1000048177	Schraube	Bolt	Boulon	Perno	1	
54	1000219290	Schlauch	Hose	Boyau	Manguera	1	
55	1000219089	Schlauch	Hose	Boyau	Manguera	1	
56	1000219023	Schlauch	Hose	Boyau	Manguera	1	
57	1000218130	Schlauch	Hose	Boyau	Manguera	1	
58	1000219096	Schlauch	Hose	Boyau	Manguera	1	
59	1000219095	Schlauch	Hose	Boyau	Manguera	1	
60	1000217380	Schlauch	Hose	Boyau	Manguera	1	
61	1000218078	Schlauch	Hose	Boyau	Manguera	1	
62	1000217947	Schlauch	Hose	Boyau	Manguera	1	
63	1000217693	Schlauch	Hose	Boyau	Manguera	1	
64	1000219188	Schlauch	Hose	Boyau	Manguera	1	
65	1000217956	Schlauch	Hose	Boyau	Manguera	1	



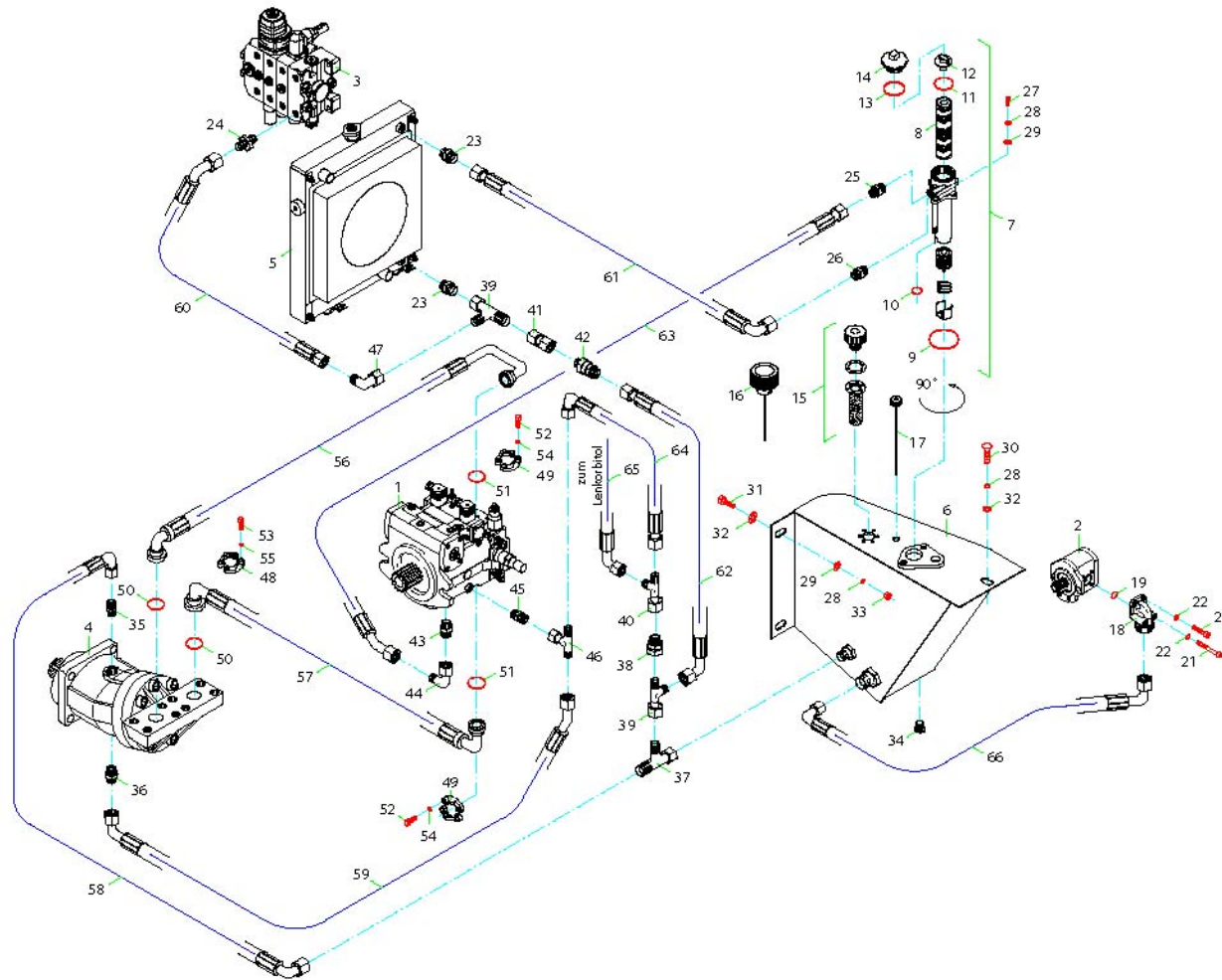

Fahrhydraulik P43/45 ab 10.2002 Drive hydraulics P43/45 from 10-2002 onwards Entraînement hydraulique P43/45 de 10-2002 et au-delà Hidráulica de accionamiento P43/45 desde 10-2002

Pos.	Artikelnr.	Bezeichnung	Description	Pièce de rechange	Parte de repuesto	Menge	Ausführung:
1	1000204448	Ölpumpe	Oil pump	Pompe à huile	Bomba de aceite	1,00	
2	1000199136	Pumpe	Pump	Pompe	Bomba	1,00	
3	1000204068	Ventil	Valve	Soupape	Válvula	1,00	
	1000206204	Ventil	Valve	Soupape	Válvula	1,00	WÜ
	1000225607	Dichtsatz	Service kit	Trousse de service	Kit de servicio	1,00	
4	1000192698	Ölmotor	Hydraulic motor	Moteur hydraulique	Motor hidráulico	1,00	
	1000192699	Ölmotor	Hydraulic motor	Moteur hydraulique	Motor hidráulico	1,00	WÜ
5	1000204935	Kühler	Cooler	Refroidisseur	Enfriador	1,00	
	1000202386	Ölkühler	Oil cooler	Refroidisseur d'huile	Refrigerador de aceite	1,00	
	1000202924	Ölkühler	Oil cooler	Refroidisseur d'huile	Refrigerador de aceite	1,00	WÜ
6	1000207493	Tank	Tank	Réservoir	Tanque	1,00	
7	1000231440	Filter	Filter	Filtre	Filtro	1,00	
8	1000231365	Filter	Filter	Filtre	Filtro	1,00	
9	1000224909	Ring	Ring	Anneau	Anillo	1,00	
10	1000224858	Ring	Ring	Anneau	Anillo	1,00	
11	1000224914	Ring	Ring	Anneau	Anillo	1,00	
12	1000226496	Stutzen	Muff	Manchon	Manguito	1,00	
13	1000225482	Dichtung	Gasket	Garniture	Junta de estanqueidad	1,00	
14	1000223085	Deckel	Cover	Couvercle	Cubierta	1,00	
15	1000196866	Stutzen	Muff	Manchon	Manguito	1,00	
16	1000231370	Filter	Filter	Filtre	Filtro	1,00	
17	1000225827	Ölmeßstab	Dipstick	Gauge à huile	Varilla medición de nivel	1,00	
18	1000021697	Verschraubung	Screw coupling	Couplage fileté	Acoplamiento roscado	1,00	
19	1000224648	Ring	Ring	Anneau	Anillo	1,00	

Fahrhydraulik P43/45 ab 10.2002 Drive hydraulics P43/45 from 10-2002 onwards Entraînement hydraulique P43/45 de 10-2002 et au-delà Hidráulica de accionamiento P43/45 desde 10-2002

Pos.	Artikelnr.	Bezeichnung	Description	Pièce de rechange	Parte de repuesto	Menge	Ausführung:
20	1000048165	Schraube	Bolt	Boulon	Perno	2,00	
21	1000085460	Schraube	Bolt	Boulon	Perno	2,00	
22	1000015444	Federring	Spring washer	Rondelle de ressort	Arandela de resorte	4,00	
23	1000225995	Verschraubung	Screw coupling	Couplage fileté	Acoplamiento roscado	2,00	
24	1000225986	Verschraubung	Screw coupling	Couplage fileté	Acoplamiento roscado	1,00	
25	1000225987	Verschraubung	Screw coupling	Couplage fileté	Acoplamiento roscado	1,00	
26	1000225995	Verschraubung	Screw coupling	Couplage fileté	Acoplamiento roscado	1,00	
27	1000048177	Schraube	Bolt	Boulon	Perno	2,00	
28	1000022016	Federring	Spring washer	Rondelle de ressort	Arandela de resorte	2,00	
29	1000015432	Scheibe	Washer	Rondelle	Disco	2,00	
30	1000048576	Schraube	Bolt	Boulon	Perno	1,00	
31	1000085355	Schraube	Bolt	Boulon	Perno	1,00	
32	1000222577	Scheibe	Washer	Rondelle	Disco	1,00	
33	1000015408	Mutter	Nut	Écrou	Tuerca	1,00	
34	1000222699	Schraube	Bolt	Boulon	Perno	1,00	
35	1000225976	Verschraubung	Screw coupling	Couplage fileté	Acoplamiento roscado	1,00	
36	1000225977	Verschraubung	Screw coupling	Couplage fileté	Acoplamiento roscado	1,00	
37	1000015517	Verschraubung	Screw coupling	Couplage fileté	Acoplamiento roscado	1,00	
38	1000085037	Verschraubung	Screw coupling	Couplage fileté	Acoplamiento roscado	1,00	
39	1000015517	Verschraubung	Screw coupling	Couplage fileté	Acoplamiento roscado	1,00	
40	1000015539	Verschraubung	Screw coupling	Couplage fileté	Acoplamiento roscado	1,00	
41	1000018398	Verschraubung	Screw coupling	Couplage fileté	Acoplamiento roscado	1,00	
42	1000194721	Ventil	Valve	Soupape	Válvula	1,00	
43	1000225997	Verschraubung	Screw coupling	Couplage fileté	Acoplamiento roscado	1,00	
44	1000020261	Verschraubung	Screw coupling	Couplage fileté	Acoplamiento roscado	1,00	

Fahrhydraulik P43/45 ab 10.2002 Drive hydraulics P43/45 from 10-2002 onwards Entraînement hydraulique P43/45 de 10-2002 et au-delà Hidráulica de accionamiento P43/45 desde 10-2002

Pos.	Artikelnr.	Bezeichnung	Description	Pièce de rechange	Parte de repuesto	Menge	Ausführung:
45	1000226175	Verschraubung	Screw coupling	Couplage fileté	Acoplamiento roscado	1,00	
46	1000085108	Verschraubung	Screw coupling	Couplage fileté	Acoplamiento roscado	1,00	
47	1000015513	Verschraubung	Screw coupling	Couplage fileté	Acoplamiento roscado	1,00	
48	1000100531	Halter	Bracket	Équerre	Soporte	2,00	
49	1000028689	Halter	Bracket	Équerre	Soporte	2,00	
50	1000225273	Ring	Ring	Anneau	Anillo	2,00	
51	1000224256	Ring	Ring	Anneau	Anillo	2,00	
52	1000082242	Schraube	Bolt	Boulon	Perno	2,00	
53	1000085476	Schraube	Bolt	Boulon	Perno	2,00	
54	1000022016	Federring	Spring washer	Rondelle de ressort	Arandela de resorte	2,00	
55	1000022017	Federring	Spring washer	Rondelle de ressort	Arandela de resorte	2,00	
56	1000220137	Schlauch	Hose	Boyau	Manguera	1,00	
57	1000220142	Schlauch	Hose	Boyau	Manguera	1,00	
58	1000220321	Schlauch	Hose	Boyau	Manguera	1,00	
59	1000220143	Schlauch	Hose	Boyau	Manguera	1,00	
60	1000220523	Schlauch	Hose	Boyau	Manguera	1,00	
61	1000220272	Schlauch	Hose	Boyau	Manguera	1,00	
62	1000220323	Schlauch	Hose	Boyau	Manguera	1,00	
63	1000217947	Schlauch	Hose	Boyau	Manguera	1,00	
64	1000219798	Schlauch	Hose	Boyau	Manguera	1,00	
65	1000220112	Schlauch	Hose	Boyau	Manguera	1,00	
66	1000220322	Schlauch	Hose	Boyau	Manguera	1,00	

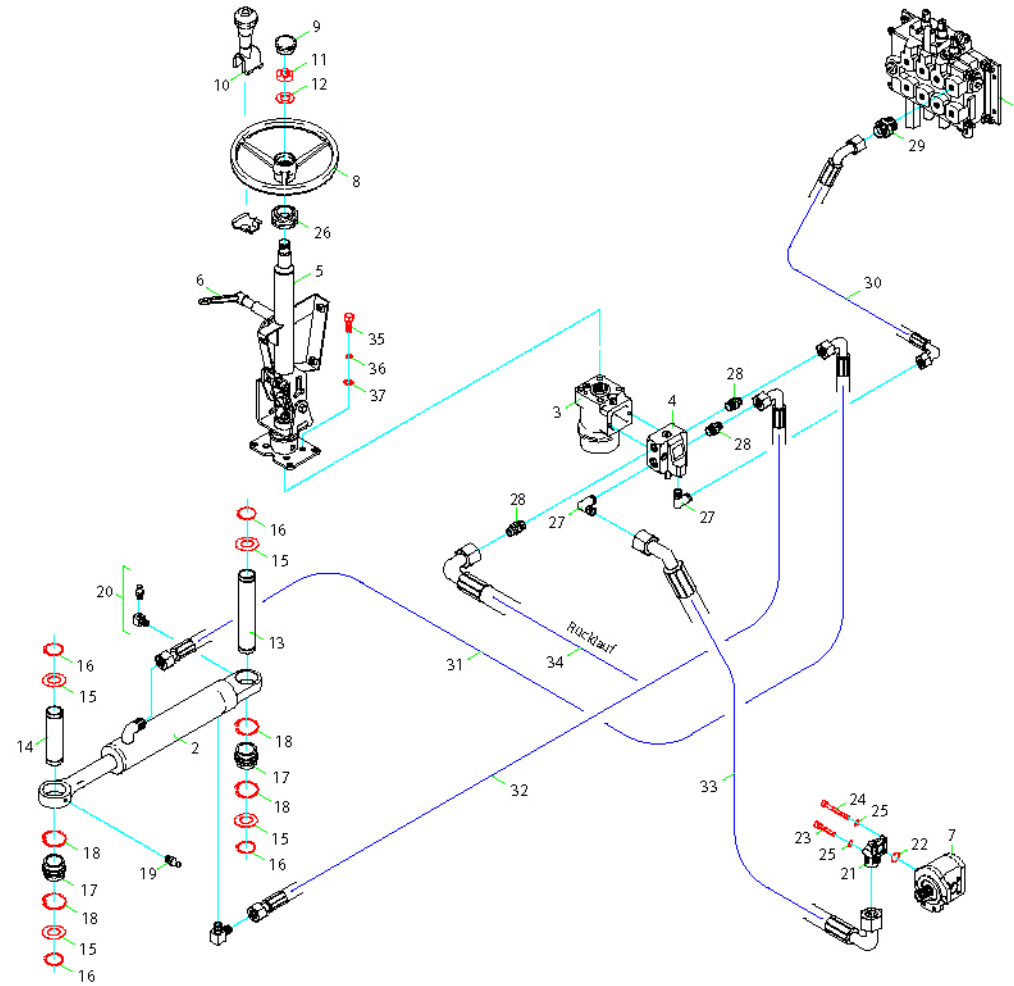



**Lenkhydraulik P33/34 Steering hydraulics P33/34 Système hydraulique de direction P33/34 Hidráulica de dirección P33/34**

Pos.	Artikelnr.	Bezeichnung	Description	Pièce de rechange	Parte de repuesto	Menge	Ausführung:
1	1000196801	Ventil	Valve	Soupape	Válvula	1	HV 07
	1000224330	Dichtsatz	Service kit	Trousse de service	Kit de servicio	1	
2	1000204068	Ventil	Valve	Soupape	Válvula	1	SDS100/3
	1000225607	Dichtsatz	Service kit	Trousse de service	Kit de servicio	1	
	1000230038	Zylinder BÜ	Cylinder BÜ	Cylindre BÜ	Cilindro BÜ	1	3483 187 BÜ Ø25 Bolzen
	1000225108	Dichtsatz M	Service kit M	Trousse de service M	Kit de servicio M	1	3186774M91
3	1000230037	Zylinder HP	Cylinder HP	Cylindre HP	Cilindro HP	1	5071532000 HP Ø30 Bolzen
	1000225774	Dichtsatz HP	Service kit HP	Trousse de service HP	Kit de servicio HP	1	3483 187 HP
	1000230048	Zylinder PH	Cylinder PH	Cylindre PH	Cilindro PH	1	31M605 PH Ø30 Bolzen
	1000225100	Dichtsatz PH	Service kit PH	Trousse de service PH	Kit de servicio PH	1	Dichtsatz H.Zyl. 31M605
	1000230041	Zylinder BÜ	Cylinder	Cylindre BÜ	Cilindro	1	5122832000 BÜ Ø30 Bolzen
	1000225779	Dichtsatz BÜ	Service kit	Trousse de service	Kit de servicio	1	5122832000 BÜ
	1000196788	Lenkung	Steering system	Système de direction	Sistema de dirección	1	
4	1000192686	Lenkung	Steering system	Système de direction	Sistema de dirección	1	
	1000196789	Lenkung	Steering system	Système de direction	Sistema de dirección	1	
	1000192688	Lenkung	Steering system	Système de direction	Sistema de dirección	1	kpl.
	1000196789	Ventil	Valve	Soupape	Válvula	1	
5	1000192690	Ventil	Valve	Soupape	Válvula	1	
	1000196945	Lenksäule	Steering column	Colonne de direction	Columna de dirección	1	starr
6	1000196944	Lenksäule	Steering column	Colonne de direction	Columna de dirección	1	verstellbar
	1000196813	Hebel	Lever	Levier	Palanca	1	
7	1000199130	Pumpe	Pump	Pompe	Bomba	1	14 ccm
	1000028062	Pumpe	Pump	Pompe	Bomba	1	16 ccm
	1000199136	Pumpe	Pump	Pompe	Bomba	1	19 ccm
	1000224657	Dichtsatz	Service kit	Trousse de service	Kit de servicio	1	



**Lenkhydraulik P33/34 Steering hydraulics P33/34 Système hydraulique de direction P33/34 Hidráulica de dirección P33/34**

Pos.	Artikelnr.	Bezeichnung	Description	Pièce de rechange	Parte de repuesto	Menge	Ausführung:
8	1000198961	Lenkrad	Steering wheel	Volant	Volante de dirección	1	
9	1000198962	Kappe	Cap	Couvercle	Tapa	1	
10	1000198964	Drehknopf	Rotary knob	Poignée rotative	Perilla rotativa	1	
11	1000222460	Mutter	Nut	Écrou	Tuerca	1	
12	1000082625	Scheibe	Washer	Rondelle	Disco	1	
13	1000224708	Bolzen	Bolt	Boulon	Perno	1	Ø 25mm
	1000224713	Bolzen	Bolt	Boulon	Perno	1	Ø 30mm
14	1000224707	Bolzen	Bolt	Boulon	Perno	1	Ø 25mm
	1000224712	Bolzen	Bolt	Boulon	Perno	1	Ø 30mm
15	1000222586	Scheibe	Washer	Rondelle	Disco	1	Ø 25mm
	1000095376	Scheibe	Washer	Rondelle	Disco	1	Ø 30mm
16	1000019253	Ring	Ring	Anneau	Anillo	1	Ø 25mm
	1000095359	Ring	Ring	Anneau	Anillo	1	Ø 30mm
17	1000224825	Lager	Bearing	Palier	Cojinete	1	Ø 25mm
	1000224827	Lager	Bearing	Palier	Cojinete	1	Ø 30mm
18	1000223218	Ring	Ring	Anneau	Anillo	1	42 x 1.5
	1000223128	Ring	Ring	Anneau	Anillo	1	47 x 1.5
19	1000222726	Schmiernippel	Grease nipple	Raccord graisseur	Boquilla de engrasar	1	
20	1000223026	Schmiernippel	Grease nipple	Raccord graisseur	Boquilla de engrasar	1	
21	1000021696	Verschraubung	Screw coupling	Couplage fileté	Acoplamiento roscado	1	
22	1000224646	Ring	Ring	Anneau	Anillo	1	
23	1000048165	Schraube	Bolt	Boulon	Perno	1	
24	1000048166	Schraube	Bolt	Boulon	Perno	1	
25	1000015444	Federring	Spring washer	Rondelle de ressort	Arandela de resorte	1	
26	1000228495	Scheibe	Washer	Rondelle	Disco	1	



**Lenkhydraulik P33/34 Steering hydraulics P33/34 Système hydraulique de direction P33/34 Hidráulica de dirección P33/34**

Pos.	Artikelnr.	Bezeichnung	Description	Pièce de rechange	Parte de repuesto	Menge	Ausführung:
27	1000225910	Verschraubung	Screw coupling	Couplage fileté	Acoplamiento roscado	1	
28	1000226177	Verschraubung	Screw coupling	Couplage fileté	Acoplamiento roscado	1	
29	1000225980	Verschraubung	Screw coupling	Couplage fileté	Acoplamiento roscado	1	
30	1000218680	Schlauch	Hose	Boyau	Manguera	1	90° / 45° 700mm
	1000220520	Schlauch	Hose	Boyau	Manguera	1	90° / 45° 1000mm
31	1000173286	Schlauch	Hose	Boyau	Manguera	1	0° / 90° 1300mm
	1000220521	Schlauch	Hose	Boyau	Manguera	1	0° / 90° 1650mm
32	1000218062	Schlauch	Hose	Boyau	Manguera	1	0° / 90° 1000mm
	1000220522	Schlauch	Hose	Boyau	Manguera	1	0° / 90° 1300mm
33	1000219046	Schlauch	Hose	Boyau	Manguera	1	90° / 90° 950mm
	1000220141	Schlauch	Hose	Boyau	Manguera	1	90° / 90° 1050mm
	1000218636	Schlauch	Hose	Boyau	Manguera	1	90° / 45° 1050mm
34	1000217380	Schlauch	Hose	Boyau	Manguera	1	0° / 90° 1650mm
	1000220112	Schlauch	Hose	Boyau	Manguera	1	90° / 90° 1800mm
35	1000015345	Schraube	Bolt	Boulon	Perno	1	
36	1000022016	Federring	Spring washer	Rondelle de ressort	Arandela de resorte	1	
37	1000015432	Scheibe	Washer	Rondelle	Disco	1	



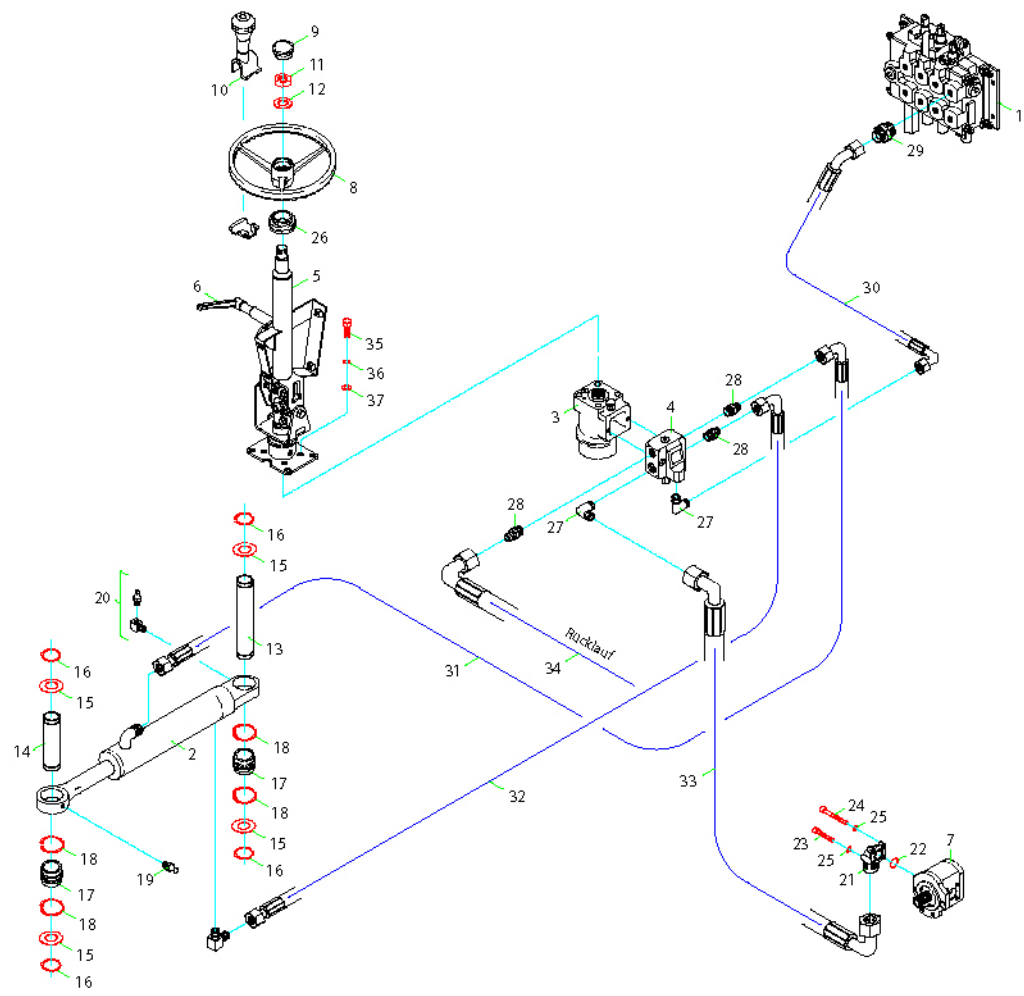

**Lenkhydraulik P43/45 Steering hydraulics P43/45 Système hydraulique de direction P43/45 Hidráulica de dirección P43/45**

Pos.	Artikelnr.	Bezeichnung	Description	Pièce de rechange	Parte de repuesto	Menge	Ausführung:
1	1000196801	Ventil	Valve	Soupape	Válvula	1	HV 07
	1000224330	Dichtsatz	Service kit	Trousse de service	Kit de servicio	1	
	1000204068	Ventil	Valve	Soupape	Válvula	1	SDS100/3
	1000225607	Dichtsatz	Service kit	Trousse de service	Kit de servicio	1	
2	1000230038	Zylinder BÜ	Cylinder	Cylindre	Cilindro	1	3483 187 BÜ Ø25 Bolzen
	1000225108	Dichtsatz M	Cylinder	Cylindre	Cilindro	1	3186774M91
	1000230037	Zylinder HP	Service kit	Trousse de service	Kit de servicio	1	5071532000 HP Ø30 Bolzen
	1000225774	Dichtsatz HP	Cylinder	Cylindre	Cilindro	1	3483 187 HP
	1000230048	Zylinder PH	Cylinder	Cylindre	Cilindro	1	31M605 PH Ø30 Bolzen
	1000225100	Dichtsatz PH	Service kit	Trousse de service	Kit de servicio	1	Dichtsatz H.Zyl. 31M605
	1000230041	Zylinder BÜ	Cylinder	Cylindre	Cilindro	1	5122832000 BÜ Ø30 Bolzen
	1000225779	Dichtsatz BÜ	Cylinder	Cylindre	Cilindro	1	5122832000 BÜ
3	1000196788	Lenkung	Steering system	Système de direction	Sistema de dirección	1	
	1000192686	Lenkung	Steering system	Système de direction	Sistema de dirección	1	
	1000196789	Lenkung	Steering system	Système de direction	Sistema de dirección	1	
	1000192688	Lenkung	Steering system	Système de direction	Sistema de dirección	1	kpl.
4	1000196789	Ventil	Valve	Soupape	Válvula	1	
	1000192690	Ventil	Valve	Soupape	Válvula	1	
5	1000196945	Lenksäule	Steering column	Colonne de direction	Columna de dirección	1	starr
	1000196944	Lenksäule	Steering column	Colonne de direction	Columna de dirección	1	verstellbar
6	1000196813	Hebel	Lever	Levier	Palanca	1	
7	1000199130	Pumpe	Pump	Pompe	Bomba	1	14 ccm
	1000028062	Pumpe	Pump	Pompe	Bomba	1	16 ccm
	1000199136	Pumpe	Pump	Pompe	Bomba	1	19 ccm
	1000224657	Dichtsatz	Service kit	Trousse de service	Kit de servicio	1	



Lenkhydraulik P43/45 Steering hydraulics P43/45 Système hydraulique de direction P43/45 Hidráulica de dirección P43/45

Pos.	Artikelnr.	Bezeichnung	Description	Pièce de rechange	Parte de repuesto	Menge	Ausführung:
8	1000198961	Lenkrad	Steering wheel	Volant	Volante de dirección	1	
9	1000198962	Kappe	Cap	Couvercle	Tapa	1	
10	1000198964	Drehknopf	Rotary knob	Poignée rotative	Perilla rotativa	1	
11	1000222460	Mutter	Nut	Écrou	Tuerca	1	
12	1000082625	Scheibe	Washer	Rondelle	Disco	1	
13	1000224708	Bolzen	Bolt	Boulon	Perno	1	Ø 25mm
	1000224713	Bolzen	Bolt	Boulon	Perno	1	Ø 30mm
14	1000224707	Bolzen	Bolt	Boulon	Perno	1	Ø 25mm
	1000224712	Bolzen	Bolt	Boulon	Perno	1	Ø 30mm
15	1000222586	Scheibe	Washer	Rondelle	Disco	1	Ø 25mm
	1000095376	Scheibe	Washer	Rondelle	Disco	1	Ø 30mm
16	1000019253	Ring	Ring	Anneau	Anillo	1	Ø 25mm
	1000095359	Ring	Ring	Anneau	Anillo	1	Ø 30mm
17	1000224825	Lager	Bearing	Palier	Cojinete	1	Ø 25mm
	1000224827	Lager	Bearing	Palier	Cojinete	1	Ø 30mm
18	1000223218	Ring	Ring	Anneau	Anillo	1	42 x 1.5
	1000223218	Ring	Ring	Anneau	Anillo	1	47 x 1.5
19	1000222726	Schmiernippel	Grease nipple	Raccord graisseur	Boquilla de engrasar	1	
20	1000223031	Schmiernippel	Grease nipple	Raccord graisseur	Boquilla de engrasar	1	
21	1000021696	Verschraubung	Screw coupling	Couplage fileté	Acoplamiento roscado	1	
22	1000224646	Ring	Ring	Anneau	Anillo	1	
23	1000048165	Schraube	Bolt	Boulon	Perno	1	
24	1000048166	Schraube	Bolt	Boulon	Perno	1	
25	1000015444	Federring	Spring washer	Rondelle de ressort	Arandela de resorte	1	
26	1000228697	Ring	Ring	Anneau	Anillo	1	

**Lenkhydraulik P43/45 Steering hydraulics P43/45 Système hydraulique de direction P43/45 Hidráulica de dirección P43/45**

Pos.	Artikelnr.	Bezeichnung	Description	Pièce de rechange	Parte de repuesto	Menge	Ausführung:
27	1000225910	Verschraubung	Screw coupling	Couplage fileté	Acoplamiento roscado	1	
28	1000226177	Verschraubung	Screw coupling	Couplage fileté	Acoplamiento roscado	1	
29	1000225980	Verschraubung	Screw coupling	Couplage fileté	Acoplamiento roscado	1	
30	1000218680	Schlauch	Hose	Boyau	Manguera	1	90° / 45° 700mm
	1000220520	Schlauch	Hose	Boyau	Manguera	1	90° / 45° 1000mm
31	1000173286	Schlauch	Hose	Boyau	Manguera	1	0° / 90° 1300mm
	1000220521	Schlauch	Hose	Boyau	Manguera	1	0° / 90° 1650mm
32	1000218062	Schlauch	Hose	Boyau	Manguera	1	0° / 90° 1000mm
	1000220522	Schlauch	Hose	Boyau	Manguera	1	0° / 90° 1300mm
33	1000218585	Schlauch	Hose	Boyau	Manguera	1	90° / 90° 900mm
	1000218622	Schlauch	Hose	Boyau	Manguera	1	90° / 45° 1000mm
	1000218543	Schlauch	Hose	Boyau	Manguera	1	90° / 90° 800mm
	1000220519	Schlauch	Hose	Boyau	Manguera	1	90° / 90° 900mm
34	1000217380	Schlauch	Hose	Boyau	Manguera	1	0° / 90° 1650mm
	1000220112	Schlauch	Hose	Boyau	Manguera	1	90° / 90° 1800mm
35	1000015354	Schraube	Bolt	Boulon	Perno	1	
36	1000022016	Federring	Spring washer	Rondelle de ressort	Arandela de resorte	1	
37	1000015432	Scheibe	Washer	Rondelle	Disco	1	



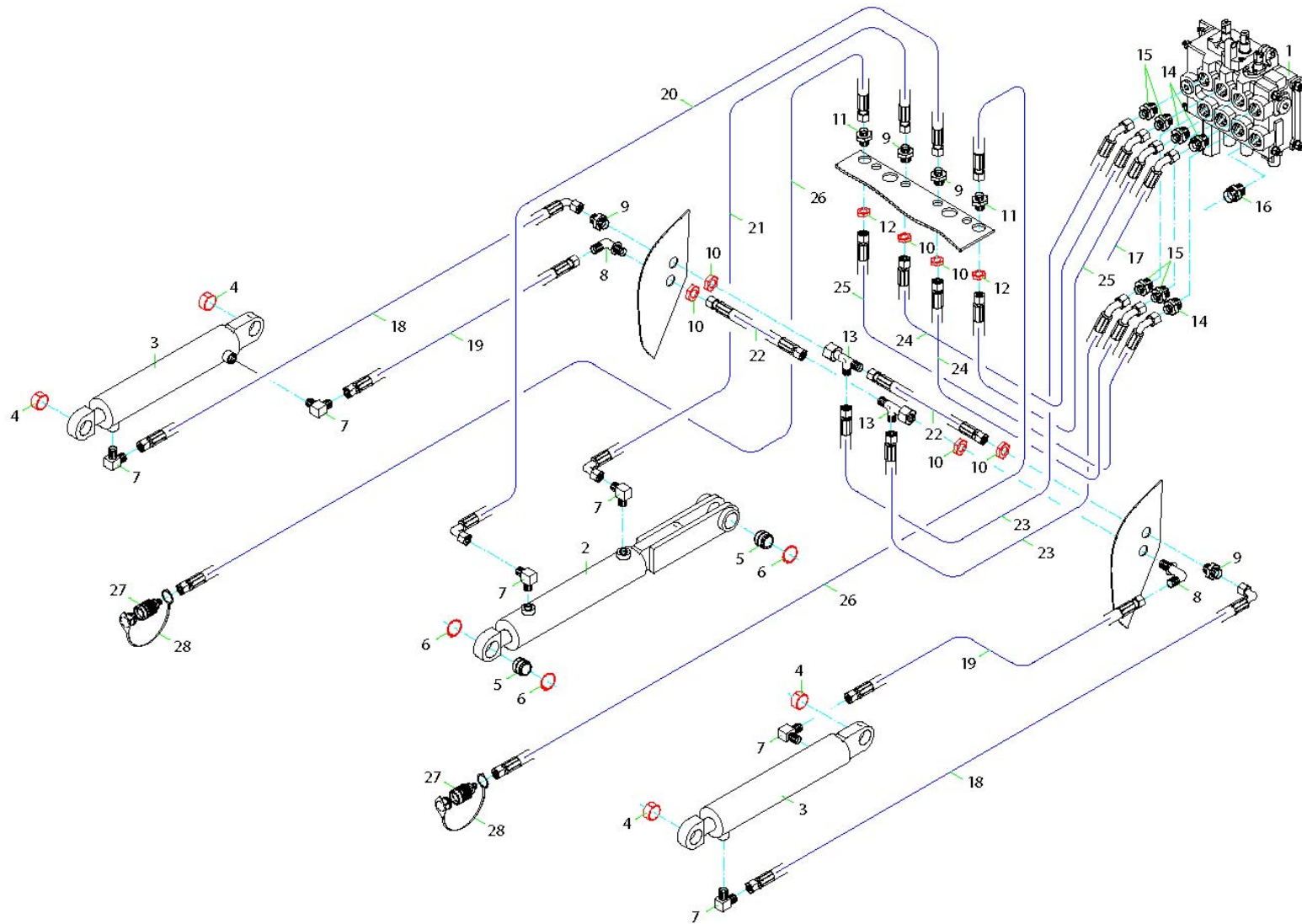



**Hydraulikanlage MV Hydraulic system MV Système hydraulique MV Sistema hidráulico MV**

Pos.	Artikelnr.	Bezeichnung	Description	Pièce de rechange	Parte de repuesto	Menge	Ausführung:
1	1000196801	Ventil	Valve	Soupape	Válvula	1	
	1000196800	Ventil	Valve	Soupape	Válvula	1	WÜ
	1000224330	Dichtsatz	Service kit	Trousse de service	Kit de servicio	1	
2	1000229980	Zylinder	Cylinder	Cylindre	Cilindro	1	
	1000229981	Zylinder	Cylinder	Cylindre	Cilindro	1	WÜ
	1000225126	Dichtsatz	Service kit	Trousse de service	Kit de servicio	1	
3	1000230090	Zylinder	Cylinder	Cylindre	Cilindro	1	
	1000230269	Zylinder	Cylinder	Cylindre	Cilindro	1	WÜ
	1000225103	Dichtsatz	Service kit	Trousse de service	Kit de servicio	1	
4	1000225631	Lager	Bearing	Palier	Cojinete	1	
5	1000224830	Lager	Bearing	Palier	Cojinete	1	
6	1000223598	Ring	Ring	Anneau	Anillo	1	
7	1000225909	Verschraubung	Screw coupling	Couplage fileté	Acoplamiento roscado	1	
8	1000085064	Verschraubung	Screw coupling	Couplage fileté	Acoplamiento roscado	1	
9	1000085076	Verschraubung	Screw coupling	Couplage fileté	Acoplamiento roscado	1	
10	1000225971	Verschraubung	Screw coupling	Couplage fileté	Acoplamiento roscado	1	
11	1000028467	Verschraubung	Screw coupling	Couplage fileté	Acoplamiento roscado	1	
12	1000225973	Verschraubung	Screw coupling	Couplage fileté	Acoplamiento roscado	1	
13	1000085089	Verschraubung	Screw coupling	Couplage fileté	Acoplamiento roscado	1	
14	1000225980	Verschraubung	Screw coupling	Couplage fileté	Acoplamiento roscado	1	
15	1000225967	Verschraubung	Screw coupling	Couplage fileté	Acoplamiento roscado	1	
16	1000225986	Verschraubung	Screw coupling	Couplage fileté	Acoplamiento roscado	1	
17	1000218680	Schlauch	Hose	Boyau	Manguera	1	
18	1000076760	Schlauch	Hose	Boyau	Manguera	1	
19	1000218169	Schlauch	Hose	Boyau	Manguera	1	



**Hydraulikanlage MV Hydraulic system MV Système hydraulique MV Sistema hidráulico MV**

Pos.	Artikelnr.	Bezeichnung	Description	Pièce de rechange	Parte de repuesto	Menge	Ausführung:
20	1000218332	Schlauch	Hose	Boyau	Manguera	1	
21	1000218053	Schlauch	Hose	Boyau	Manguera	1	
22	1000218089	Schlauch	Hose	Boyau	Manguera	1	
23	1000187481	Schlauch	Hose	Boyau	Manguera	1	
24	1000187531	Schlauch	Hose	Boyau	Manguera	1	
25	1000219061	Schlauch	Hose	Boyau	Manguera	1	
26	1000218495	Schlauch	Hose	Boyau	Manguera	1	
27	1000226162	Kupplung	Coupling	Couplage	Acoplamiento	1	
28	1000186757	Deckel	Cover	Couvercle	Cubierta	1	





**WEIDEMANN**

**Weidemann 1360**

**-171-**

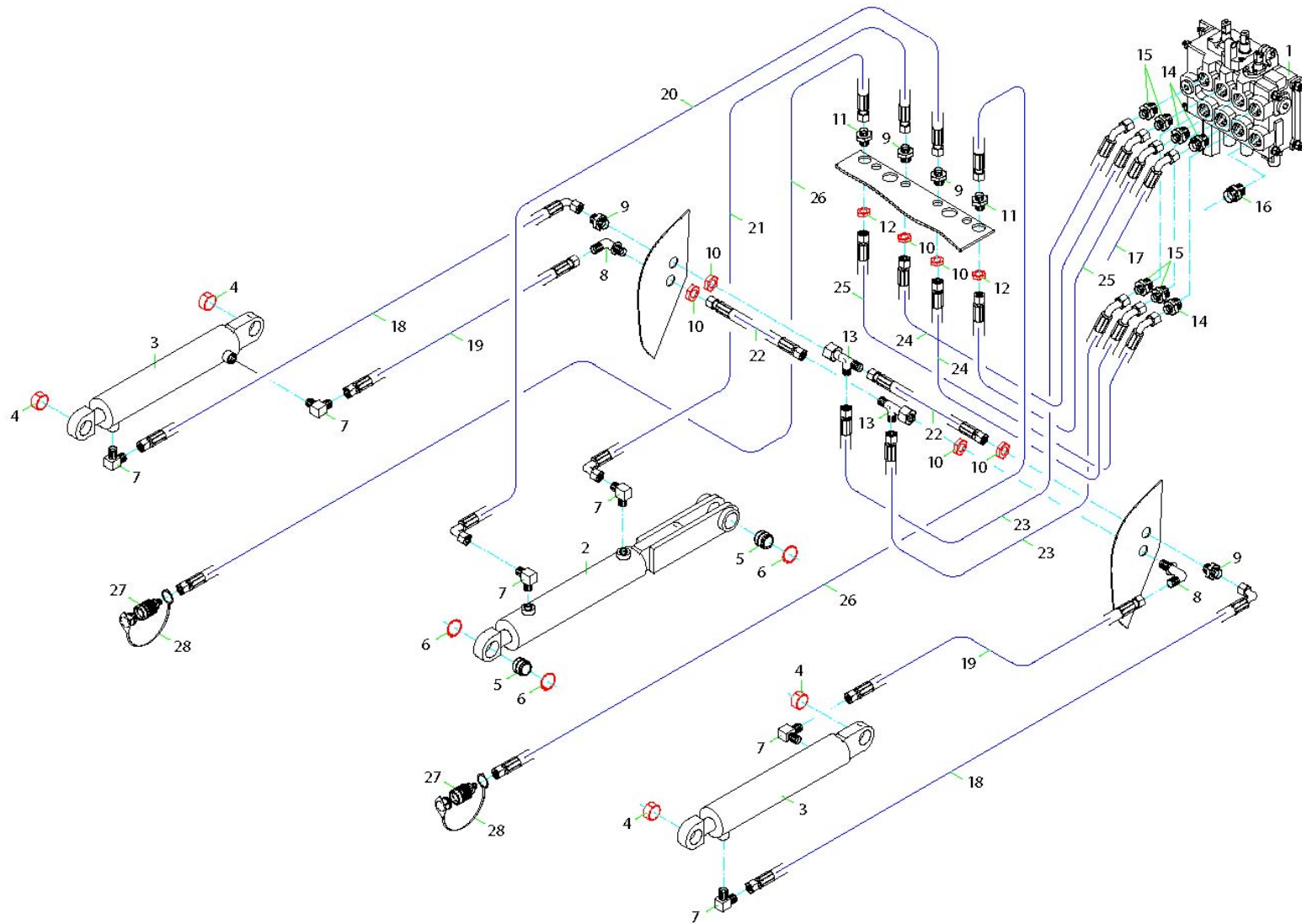

**Hydraulikanlage MV HH Hydraulic system MV HH Système hydraulique MV HH Sistema hidráulico MV HH**

Pos.	Artikelnr.	Bezeichnung	Description	Pièce de rechange	Parte de repuesto	Menge	Ausführung:
1	1000196801	Ventil	Valve	Soupape	Válvula	1	
	1000196800	Ventil	Valve	Soupape	Válvula	1	WÜ
	1000224330	Dichtsatz	Service kit	Trousse de service	Kit de servicio	1	
2	1000229980	Zylinder	Cylinder	Cylindre	Cilindro	1	
	1000229981	Zylinder	Cylinder	Cylindre	Cilindro	1	WÜ
	1000225126	Dichtsatz	Service kit	Trousse de service	Kit de servicio	1	
3	1000230090	Zylinder	Cylinder	Cylindre	Cilindro	1	
	1000230269	Zylinder	Cylinder	Cylindre	Cilindro	1	WÜ
	1000225103	Dichtsatz	Service kit	Trousse de service	Kit de servicio	1	
4	1000225631	Lager	Bearing	Palier	Cojinete	1	
5	1000224830	Lager	Bearing	Palier	Cojinete	1	
6	1000223598	Ring	Ring	Anneau	Anillo	1	
7	1000225909	Verschraubung	Screw coupling	Couplage fileté	Acoplamiento roscado	1	
8	1000085064	Verschraubung	Screw coupling	Couplage fileté	Acoplamiento roscado	1	
9	1000085076	Verschraubung	Screw coupling	Couplage fileté	Acoplamiento roscado	1	
10	1000225971	Verschraubung	Screw coupling	Couplage fileté	Acoplamiento roscado	1	
11	1000028467	Verschraubung	Screw coupling	Couplage fileté	Acoplamiento roscado	1	
12	1000225973	Verschraubung	Screw coupling	Couplage fileté	Acoplamiento roscado	1	
13	1000085089	Verschraubung	Screw coupling	Couplage fileté	Acoplamiento roscado	1	
14	1000225980	Verschraubung	Screw coupling	Couplage fileté	Acoplamiento roscado	1	
15	1000225967	Verschraubung	Screw coupling	Couplage fileté	Acoplamiento roscado	1	
16	1000225986	Verschraubung	Screw coupling	Couplage fileté	Acoplamiento roscado	1	
17	1000218680	Schlauch	Hose	Boyau	Manguera	1	
18	1000076760	Schlauch	Hose	Boyau	Manguera	1	
19	1000218169	Schlauch	Hose	Boyau	Manguera	1	



Hydraulikanlage MV HH Hydraulic system MV HH Système hydraulique MV HH Sistema hidráulico MV HH

Pos.	Artikelnr.	Bezeichnung	Description	Pièce de rechange	Parte de repuesto	Menge	Ausführung:
20	1000218332	Schlauch	Hose	Boyau	Manguera	1	
21	1000218033	Schlauch	Hose	Boyau	Manguera	1	
22	1000218089	Schlauch	Hose	Boyau	Manguera	1	
23	1000187481	Schlauch	Hose	Boyau	Manguera	1	
24	1000187531	Schlauch	Hose	Boyau	Manguera	1	
25	1000219061	Schlauch	Hose	Boyau	Manguera	1	
26	1000218514	Schlauch	Hose	Boyau	Manguera	1	
27	1000226162	Kupplung	Coupling	Couplage	Acoplamiento	1	
28	1000186757	Deckel	Cover	Couvercle	Cubierta	1	





**WEIDEMANN**

**Weidemann 1360**

**-175-**

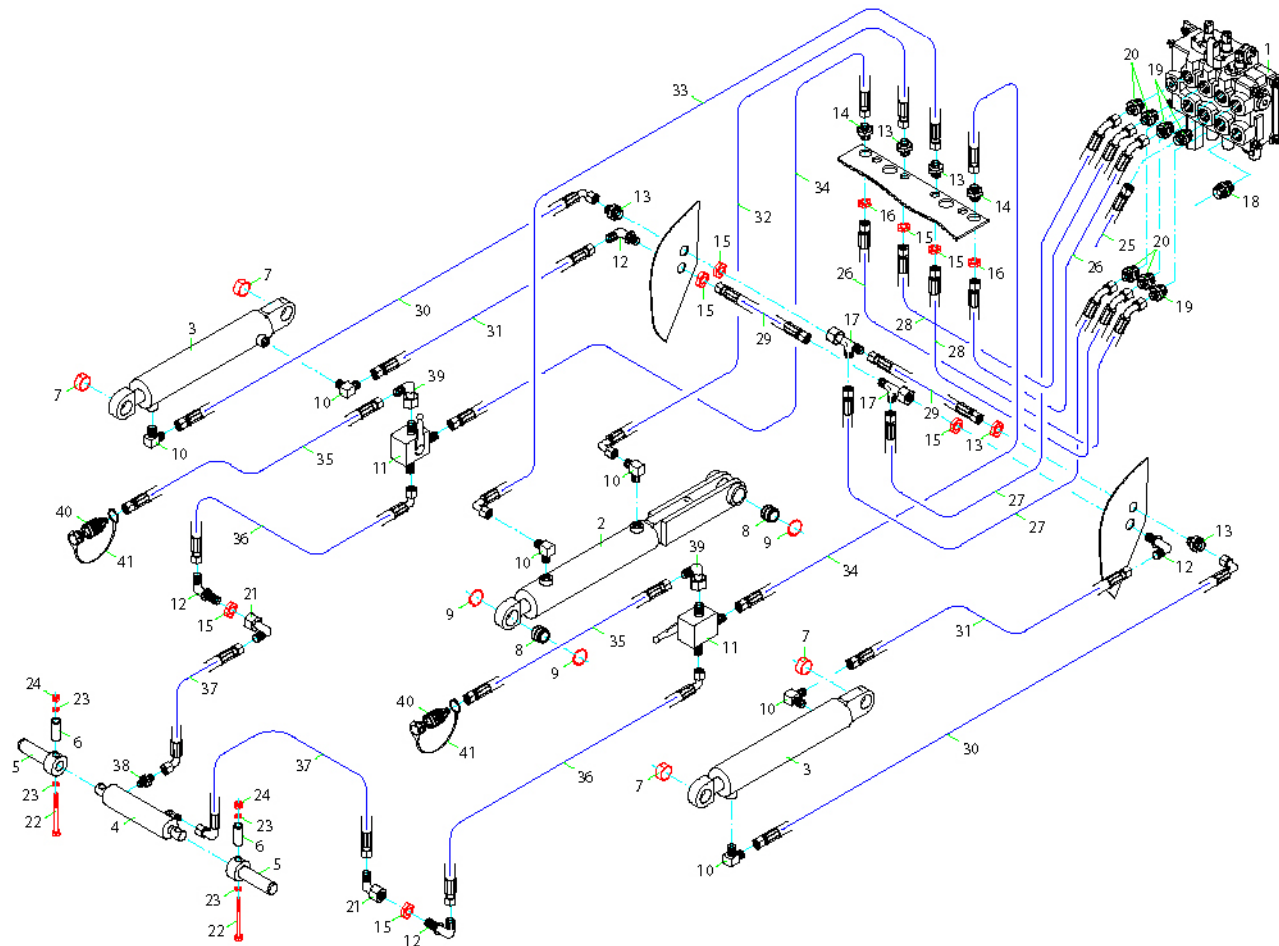



**Hydraulikanlage HV Hydraulic system HV Système hydraulique HV Sistema hidráulico HV**

Pos.	Artikelnr.	Bezeichnung	Description	Pièce de rechange	Parte de repuesto	Menge	Ausführung:
1	1000196801	Ventil	Valve	Soupape	Válvula	1	
2	1000229980	Zylinder	Cylinder	Cylindre	Cilindro	1	3622 954 M
	1000229981	Zylinder	Cylinder	Cylindre	Cilindro	1	3622 954 M WÜ
	1000225126	Dichtsatz	Service kit	Trousse de service	Kit de servicio	1	
	1000229978	Zylinder	Cylinder	Cylindre	Cilindro	1	80/40/440 Bü
	1000229983	Zylinder	Cylinder	Cylindre	Cilindro	1	80/40/440 Bü WÜ
	1000225146	Dichtsatz	Service kit	Trousse de service	Kit de servicio	1	
3	1000230090	Zylinder	Cylinder	Cylindre	Cilindro	1	3622 160 HP
	1000230269	Zylinder	Cylinder	Cylindre	Cilindro	1	WÜ
	1000225103	Dichtsatz	Service kit	Trousse de service	Kit de servicio	1	
	1000230084	Zylinder	Cylinder	Cylindre	Cilindro	1	31M667 PH
	1000225102	Dichtsatz	Service kit	Trousse de service	Kit de servicio	1	
4	1000230013	Zylinder	Cylinder	Cylindre	Cilindro	1	3622 566 M
	1000230243	Zylinder	Cylinder	Cylindre	Cilindro	1	3622 566 M WÜ
	1000225122	Dichtsatz	Service kit	Trousse de service	Kit de servicio	1	
5	1000222385	Bolzen	Bolt	Boulon	Perno	1	
6	1000196350	Hülse	Sleeve	Manchon	Manguito	1	
7	1000225631	Lager	Bearing	Palier	Cojinete	1	
8	1000224830	Lager	Bearing	Palier	Cojinete	1	
9	1000223598	Ring	Ring	Anneau	Anillo	1	
10	1000225909	Verschraubung	Screw coupling	Couplage fileté	Acoplamiento roscado	1	
11	1000199063	Hahn	Valve	Soupape	Válvula	1	
12	1000085064	Verschraubung	Screw coupling	Couplage fileté	Acoplamiento roscado	1	
13	1000085076	Verschraubung	Screw coupling	Couplage fileté	Acoplamiento roscado	1	
14	1000028467	Verschraubung	Screw coupling	Couplage fileté	Acoplamiento roscado	1	



**Hydraulikanlage HV Hydraulic system HV Système hydraulique HV Sistema hidráulico HV**

Pos.	Artikelnr.	Bezeichnung	Description	Pièce de rechange	Parte de repuesto	Menge	Ausführung:
15	1000225971	Verschraubung	Screw coupling	Couplage fileté	Acoplamiento roscado	1	
16	1000225973	Verschraubung	Screw coupling	Couplage fileté	Acoplamiento roscado	1	
17	1000085089	Verschraubung	Screw coupling	Couplage fileté	Acoplamiento roscado	1	
18	1000225986	Verschraubung	Screw coupling	Couplage fileté	Acoplamiento roscado	1	
19	1000225980	Verschraubung	Screw coupling	Couplage fileté	Acoplamiento roscado	1	
20	1000225967	Verschraubung	Screw coupling	Couplage fileté	Acoplamiento roscado	1	
21	1000015510	Verschraubung	Screw coupling	Couplage fileté	Acoplamiento roscado	1	
22	1000222557	Schraube	Bolt	Boulon	Perno	1	
23	1000019126	Scheibe	Washer	Rondelle	Disco	1	
24	1000049060	Mutter	Nut	Écrou	Tuerca	1	
25	1000218680	Schlauch	Hose	Boyau	Manguera	1	
26	1000219061	Schlauch	Hose	Boyau	Manguera	1	
27	1000187481	Schlauch	Hose	Boyau	Manguera	1	
28	1000187531	Schlauch	Hose	Boyau	Manguera	1	
29	1000218089	Schlauch	Hose	Boyau	Manguera	1	
30	1000076760	Schlauch	Hose	Boyau	Manguera	1	
31	1000218169	Schlauch	Hose	Boyau	Manguera	1	
32	1000218053	Schlauch	Hose	Boyau	Manguera	1	
33	1000218332	Schlauch	Hose	Boyau	Manguera	1	
34	1000218672	Schlauch	Hose	Boyau	Manguera	1	
35	1000218639	Schlauch	Hose	Boyau	Manguera	1	
36	1000218196	Schlauch	Hose	Boyau	Manguera	1	
37	1000076721	Schlauch	Hose	Boyau	Manguera	1	
38	1000226007	Verschraubung	Screw coupling	Couplage fileté	Acoplamiento roscado	1	
39	1000015512	Verschraubung	Screw coupling	Couplage fileté	Acoplamiento roscado	1	



**Hydraulikanlage HV Hydraulic system HV Système hydraulique HV Sistema hidráulico HV**

Pos.	Artikelnr.	Bezeichnung	Description	Pièce de rechange	Parte de repuesto	Menge	Ausführung:
40	1000226162	Kupplung	Coupling	Couplage	Acoplamiento	1	
41	1000186757	Deckel	Cover	Couvercle	Cubierta	1	



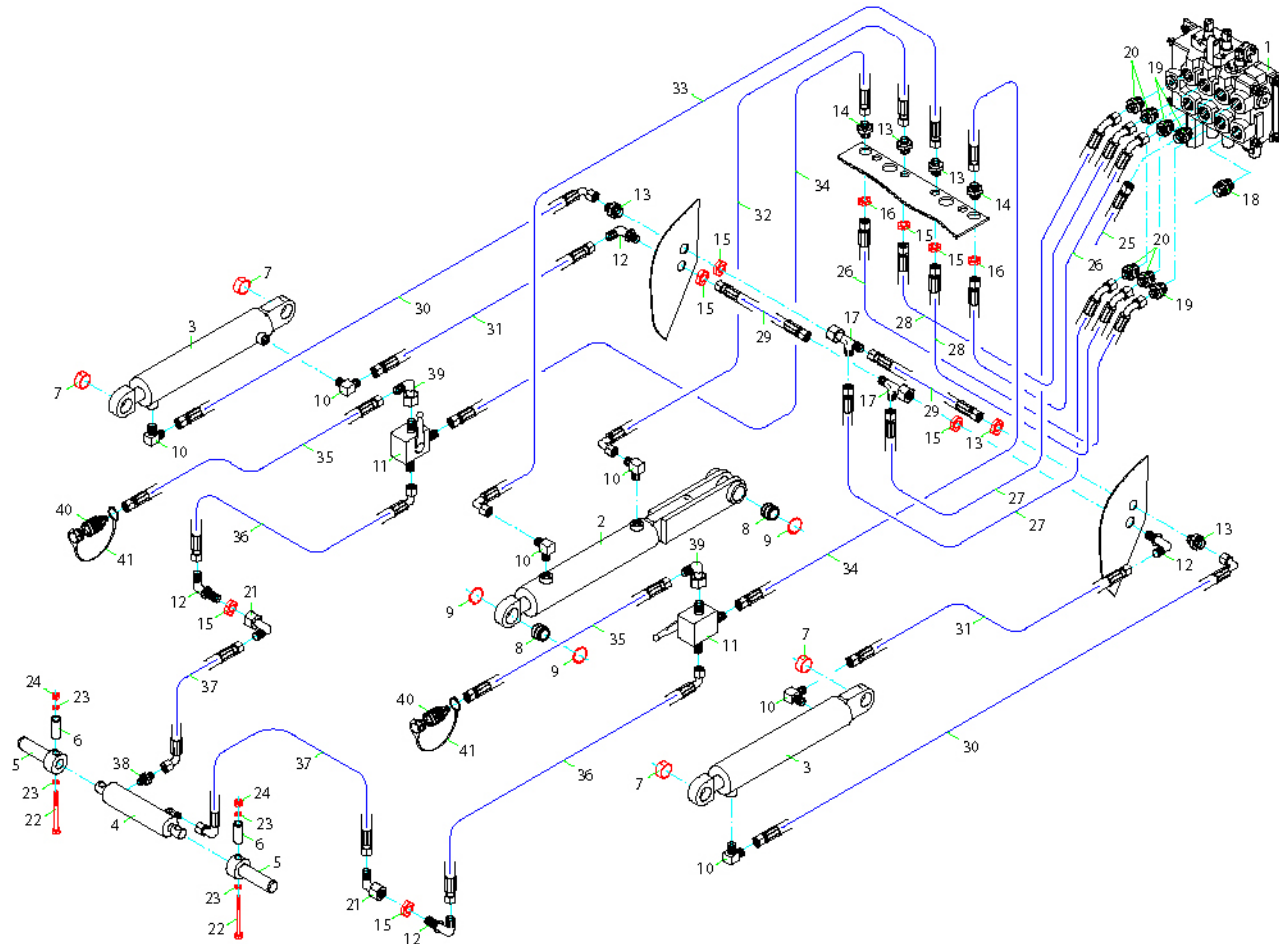

**Hydraulikanlage HV HH Hydraulic system HV HH Système hydraulique HV HH Sistema hidráulico HV HH**

Pos.	Artikelnr.	Bezeichnung	Description	Pièce de rechange	Parte de repuesto	Menge	Ausführung:
1	1000196801	Ventil	Valve	Soupape	Válvula	1	
2	1000229980	Zylinder	Cylinder	Cylindre	Cilindro	1	3622 954 M
	1000229981	Zylinder	Cylinder	Cylindre	Cilindro	1	3622 954 M WÜ
	1000225126	Dichtsatz	Service kit	Trousse de service	Kit de servicio	1	
	1000229978	Zylinder	Cylinder	Cylindre	Cilindro	1	80/40/440 Bü
	1000229983	Zylinder	Cylinder	Cylindre	Cilindro	1	80/40/440 Bü WÜ
	1000225146	Dichtsatz	Service kit	Trousse de service	Kit de servicio	1	
3	1000230090	Zylinder	Cylinder	Cylindre	Cilindro	1	3622 160 HP
	1000230269	Zylinder	Cylinder	Cylindre	Cilindro	1	3622 160 HP WÜ
	1000225103	Dichtsatz	Service kit	Trousse de service	Kit de servicio	1	
	1000230084	Zylinder	Cylinder	Cylindre	Cilindro	1	31M667 PH
	1000225102	Dichtsatz	Service kit	Trousse de service	Kit de servicio	1	
4	1000230013	Zylinder	Cylinder	Cylindre	Cilindro	1	
	1000230243	Zylinder	Cylinder	Cylindre	Cilindro	1	WÜ
	1000225122	Dichtsatz	Service kit	Trousse de service	Kit de servicio	1	
5	1000222385	Bolzen	Bolt	Boulon	Perno	1	
6	1000196350	Hülse	Sleeve	Manchon	Manguito	1	
7	1000225631	Lager	Bearing	Palier	Cojinete	1	
8	1000224830	Lager	Bearing	Palier	Cojinete	1	
9	1000223598	Ring	Ring	Anneau	Anillo	1	
10	1000225909	Verschraubung	Screw coupling	Couplage fileté	Acoplamiento roscado	1	
11	1000199063	Hahn	Valve	Soupape	Válvula	1	
12	1000085064	Verschraubung	Screw coupling	Couplage fileté	Acoplamiento roscado	1	
13	1000085076	Verschraubung	Screw coupling	Couplage fileté	Acoplamiento roscado	1	
14	1000028467	Verschraubung	Screw coupling	Couplage fileté	Acoplamiento roscado	1	

**Hydraulikanlage HV HH Hydraulic system HV HH Système hydraulique HV HH Sistema hidráulico HV HH**

Pos.	Artikelnr.	Bezeichnung	Description	Pièce de rechange	Parte de repuesto	Menge	Ausführung:
15	1000225971	Verschraubung	Screw coupling	Couplage fileté	Acoplamiento roscado	1	
16	1000225973	Verschraubung	Screw coupling	Couplage fileté	Acoplamiento roscado	1	
17	1000085089	Verschraubung	Screw coupling	Couplage fileté	Acoplamiento roscado	1	
18	1000225986	Verschraubung	Screw coupling	Couplage fileté	Acoplamiento roscado	1	
19	1000225980	Verschraubung	Screw coupling	Couplage fileté	Acoplamiento roscado	1	
20	1000225967	Verschraubung	Screw coupling	Couplage fileté	Acoplamiento roscado	1	
21	1000015510	Verschraubung	Screw coupling	Couplage fileté	Acoplamiento roscado	1	
22	1000222557	Schraube	Bolt	Boulon	Perno	1	
23	1000019126	Scheibe	Washer	Rondelle	Disco	1	
24	1000049060	Mutter	Nut	Écrou	Tuerca	1	
25	1000218680	Schlauch	Hose	Boyau	Manguera	1	
26	1000219061	Schlauch	Hose	Boyau	Manguera	1	
27	1000187481	Schlauch	Hose	Boyau	Manguera	1	
28	1000187531	Schlauch	Hose	Boyau	Manguera	1	
29	1000218089	Schlauch	Hose	Boyau	Manguera	1	
30	1000076760	Schlauch	Hose	Boyau	Manguera	1	
31	1000218169	Schlauch	Hose	Boyau	Manguera	1	
32	1000218033	Schlauch	Hose	Boyau	Manguera	1	
33	1000218332	Schlauch	Hose	Boyau	Manguera	1	
34	1000218685	Schlauch	Hose	Boyau	Manguera	1	
35	1000218672	Schlauch	Hose	Boyau	Manguera	1	
36	1000218040	Schlauch	Hose	Boyau	Manguera	1	
37	1000076721	Schlauch	Hose	Boyau	Manguera	1	
38	1000226007	Verschraubung	Screw coupling	Couplage fileté	Acoplamiento roscado	1	
39	1000015512	Verschraubung	Screw coupling	Couplage fileté	Acoplamiento roscado	1	



Hydraulikanlage HV HH Hydraulic system HV HH Système hydraulique HV HH Sistema hidráulico HV HH

Pos.	Artikelnr.	Bezeichnung	Description	Pièce de rechange	Parte de repuesto	Menge	Ausführung:
40	1000226162	Kupplung	Coupling	Couplage	Acoplamiento	1	
41	1000186757	Deckel	Cover	Couvercle	Cubierta	1	

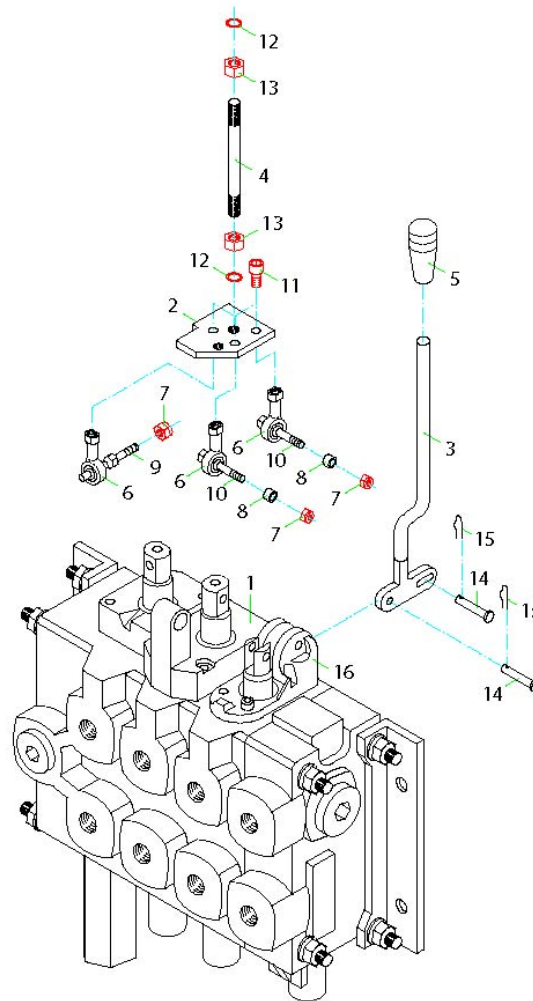



Kreuzsteuerventil HV 07 Cross control valve HV 07 Valve de croisement de commande HV 07 Válvula de control superior HV 07

Pos.	Artikelnr.	Bezeichnung	Description	Pièce de rechange	Parte de repuesto	Menge	Ausführung:
1	1000196801	Ventil	Valve	Soupape	Válvula	1	
	1000196800	Ventil	Valve	Soupape	Válvula	1	WÜ
	1000224330	Dichtsatz	Service kit	Trousse de service	Kit de servicio	1	
2	1000226501	Aufnahmeplatte	Insert plate	Plaque d'insertion	Placa del inserto	1	
3	1000225818	Hebel	Lever	Levier	Palanca	1	
4	1000203619	Schraube	Bolt	Boulon	Perno	1	
5	1000225940	Griff	Handle	Poignée	Mango	1	
6	1000223722	Gelenkkopf	Swivel head	Tête à rotule	Cabezal giratorio	1	
7	1000015412	Mutter	Nut	Écrou	Tuerca	1	
8	1000196891	Hülse	Sleeve	Manchon	Manguito	1	
9	1000225964	Schraube	Bolt	Boulon	Perno	1	
10	1000225963	Schraube	Bolt	Boulon	Perno	1	
11	1000019593	Schraube	Bolt	Boulon	Perno	1	
12	1000022017	Federring	Spring washer	Rondelle de ressort	Arandela de resorte	1	
13	1000049000	Mutter	Nut	Écrou	Tuerca	1	
14	1000225664	Bolzen	Bolt	Boulon	Perno	1	
15	1000223442	Federstecker	Hairpin spring	Ressort à arc	Resorte en V	1	
16	1000226012	Halterung	Bracket	Équerre	Soporte	1	



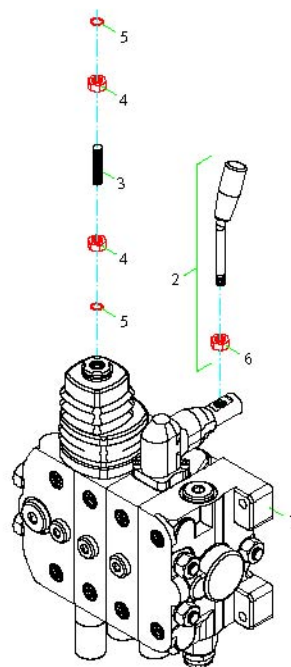

Kreuzsteuerventil SDS 100 Cross control valve SDS 100 Valve de croisement de commande SDS 100 Válvula de control superior SDS 100

Pos.	Artikelnr.	Bezeichnung	Description	Pièce de rechange	Parte de repuesto	Menge	Ausführung:
1	1000204068	Ventil	Valve	Soupape	Válvula	1,00	
	1000206204	Ventil	Valve	Soupape	Válvula	1,00	WÜ
	1000225607	Dichtsatz	Service kit	Trousse de service	Kit de servicio	1,00	
2	1000225947	Hebel	Lever	Levier	Palanca	1,00	
3	1000222690	Schraube	Bolt	Boulon	Perno	1,00	
4	1000049000	Mutter	Nut	Écrou	Tuerca	1,00	
5	1000223943	Scheibe	Washer	Rondelle	Disco	1,00	
6	1000015407	Mutter	Nut	Écrou	Tuerca	1,00	

Bremsanlage K Achse bis 10.2002 Brake system K Axle up to 10-2002 Système de freinage essieu K jusqu'à 10-2002 Sistema de frenos Eje K hasta 10-2002

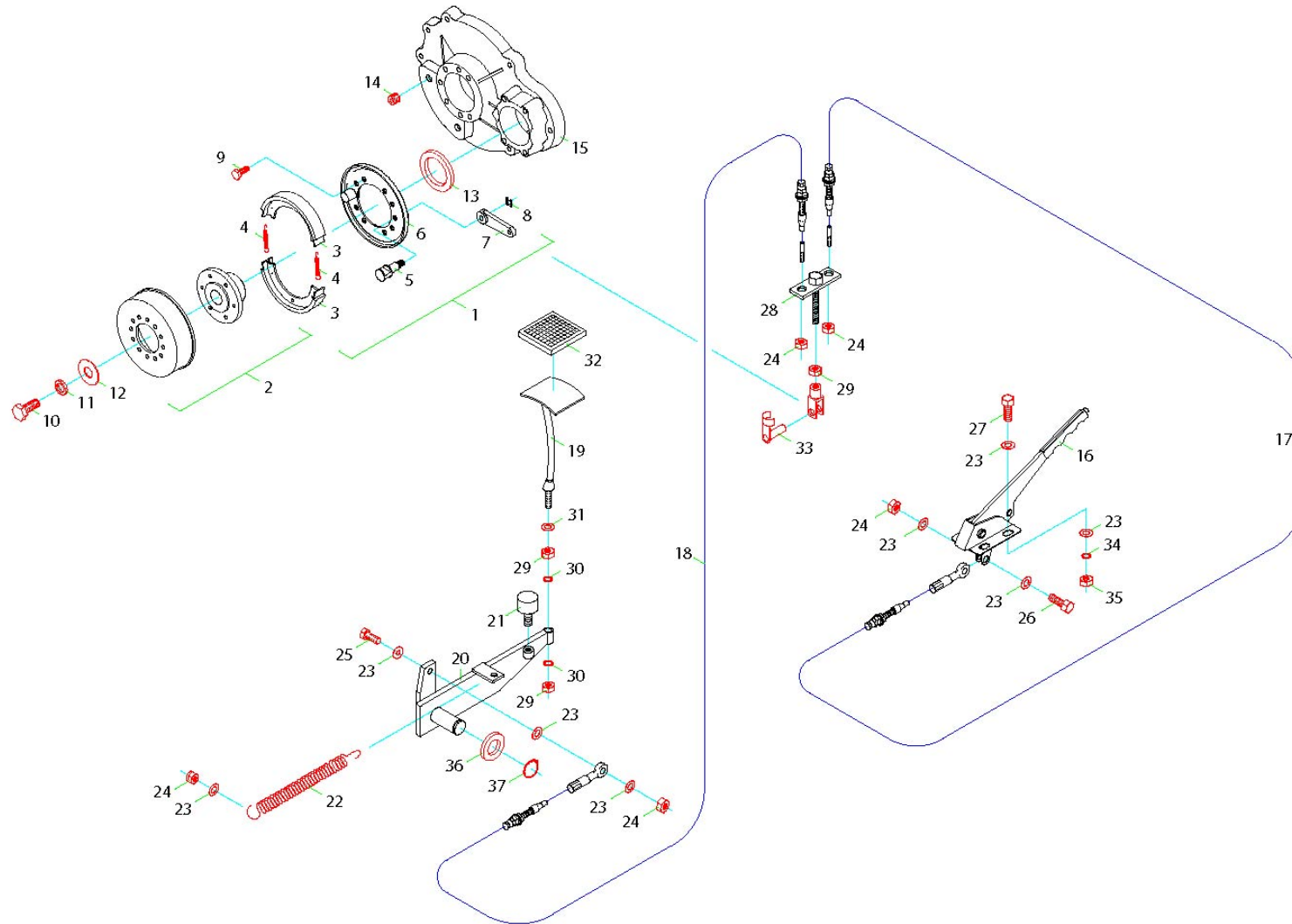

**Bremsanlage K Achse bis 10.2002 Brake system K Axle up to 10-2002 Système de freinage essieu K jusqu'à 10-2002 Sistema de frenos Eje K hasta 10-2002**

Pos.	Artikelnr.	Bezeichnung	Description	Pièce de rechange	Parte de repuesto	Menge
1	1000196973	Bremse	Brake	Frein	Freno	1
2	1000193645	Bremstrommel	Brake drum	Tambour de frein	Tambor de freno	1
3	1000196977	Bremsbacken	Brake shoes	Sabots de frein	Pastillas de freno	1
4	1000222939	Feder	Spring	Ressort	Resorte	1
5	1000196978	Bolzen	Bolt	Boulon	Perno	1
6	1000196973	Bremsankerplatte	Brake anchoring plate	Chape de fixation du frein	Placa de anclaje del freno	1
7	1000196975	Hebel	Lever	Levier	Palanca	1
8	1000196976	Sicherung	Retainer	Dispositif de retenue	Retén	1
9	1000015345	Schraube	Bolt	Boulon	Perno	1
10	1000015347	Schraube	Bolt	Boulon	Perno	1
11	1000022017	Federring	Spring washer	Rondelle de ressort	Arandela de resorte	1
12	1000223005	Scheibe	Washer	Rondelle	Disco	1
13	1000225477	Wellendichtring	Sealing ring	Bague de scellement	Anillo de sellado	1
14	1000222717	Schraube	Bolt	Boulon	Perno	1
15	1000192598	Deckel	Cover	Couvercle	Cubierta	1
16	1000196803	Hebel	Lever	Levier	Palanca	1
17	1000222903	Bowdenzug	Bowden cable	Câble de Bowden	Cable Bowden	1
18	1000222900	Bowdenzug	Bowden cable	Câble de Bowden	Cable Bowden	1
19	1000195109	Hebel	Lever	Levier	Palanca	1
20	1000203048	Hebel	Lever	Levier	Palanca	1
21	1000228510	Gummipuffer	Silent block	Silentbloc	Bloque silente	1
22	1000200250	Feder	Spring	Ressort	Resorte	1
23	1000222819	Scheibe	Washer	Rondelle	Disco	1
24	1000015412	Mutter	Nut	Écrou	Tuerca	1
25	1000085391	Schraube	Bolt	Boulon	Perno	1

**Bremsanlage K Achse bis 10.2002 Brake system K Axle up to 10-2002 Système de freinage essieu K jusqu'à 10-2002 Sistema de frenos Eje K hasta 10-2002**

Pos.	Artikelnr.	Bezeichnung	Description	Pièce de rechange	Parte de repuesto	Menge
26	1000015343	Schraube	Bolt	Boulon	Perno	1
27	1000015343	Schraube	Bolt	Boulon	Perno	1
28	1000202247	Gabelkopf	Swivel head	Tête à rotule	Cabezal giratorio	1
29	1000015407	Mutter	Nut	Écrou	Tuerca	1
30	1000022016	Federring	Spring washer	Rondelle de ressort	Arandela de resorte	1
31	1000015432	Scheibe	Washer	Rondelle	Disco	1
32	1000228627	Bezug	Cover	Couvercle	Cubierta	1
33	1000222571	Gabelkopf	Swivel head	Tête à rotule	Cabezal giratorio	1
34	1000082617	Federring	Spring washer	Rondelle de ressort	Arandela de resorte	1
35	1000015406	Mutter	Nut	Écrou	Tuerca	1
36	1000095351	Scheibe	Washer	Rondelle	Disco	1
37	1000095358	Ring	Ring	Anneau	Anillo	1





**WEIDEMANN**

**Weidemann 1360**

**-191-**

Bremsanlage K Achse ab 10.2002 Brake system K Axle from 10-2002 onwards Système de freinage essieu K et 10-2002 et au-delà Sistema de frenos Eje K desde 10-2002

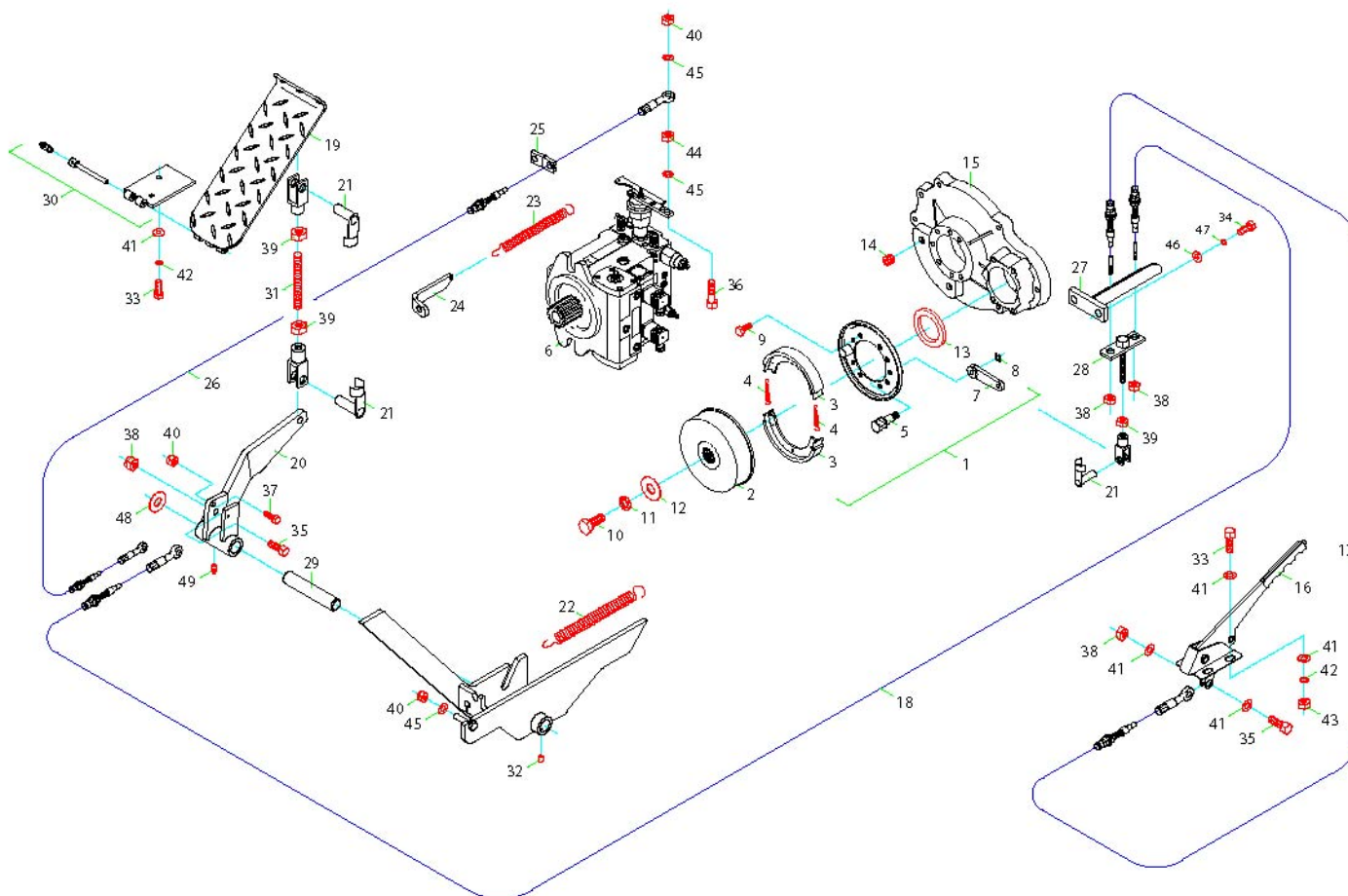



**Bremsanlage K Achse ab 10.2002 Brake system K Axle from 10-2002 onwards Système de freinage essieu K et 10-2002 et au-delà Sistema de frenos Eje K desde 10-2002**

Pos.	Artikelnr.	Bezeichnung	Description	Pièce de rechange	Parte de repuesto	Menge	Ausführung:
1	1000196973	Bremse	Brake	Frein	Freno	1,00	p. Bremstrommel
	1000196972	Bremse	Brake	Frein	Freno	1,00	m. Bremstrommel
2	1000193645	Bremstrommel	Brake drum	Tambour de frein	Tambor de freno	1,00	
3	1000196977	Bremsbacken	Brake shoes	Sabots de frein	Pastillas de freno	1,00	
4	1000222939	Feder	Spring	Ressort	Resorte	2,00	
5	1000196978	Bolzen	Bolt	Boulon	Perno	1,00	
6	1000205858	Ölpumpe	Oil pump	Pompe à huile	Bomba de aceite	1,00	
7	1000196975	Hebel	Lever	Levier	Palanca	1,00	
8	1000196976	Sicherung	Retainer	Dispositif de retenue	Retén	1,00	
9	1000015345	Schraube	Bolt	Boulon	Perno	4,00	
10	1000015347	Schraube	Bolt	Boulon	Perno	1,00	
11	1000022017	Federring	Spring washer	Rondelle de ressort	Arandela de resorte	1,00	
12	1000223005	Scheibe	Washer	Rondelle	Disco	1,00	
13	1000225477	Wellendichtring	Sealing ring	Bague de scellement	Anillo de sellado	1,00	
14	1000222717	Schraube	Bolt	Boulon	Perno	1,00	
15	1000192598	Deckel	Cover	Couvercle	Cubierta	1,00	
16	1000196803	Hebel	Lever	Levier	Palanca	1,00	
17	1000222903	Bowdenzug	Bowden cable	Câble de Bowden	Cable Bowden	1,00	
18	1000222900	Bowdenzug	Bowden cable	Câble de Bowden	Cable Bowden	1,00	
19	1000205077	Pedal	Pedal	Pédale	Pedal	1,00	
20	1000205071	Hebel	Lever	Levier	Palanca	1,00	
21	1000222571	Gabelkopf	Swivel head	Tête à rotule	Cabezal giratorio	1,00	
22	1000200250	Feder	Spring	Ressort	Resorte	1,00	
23	1000222932	Feder	Spring	Ressort	Resorte	1,00	
24	1000203136	Halterung	Bracket	Équerre	Soporte	1,00	

**Bremsanlage K Achse ab 10.2002 Brake system K Axle from 10-2002 onwards Système de freinage essieu K et 10-2002 et au-delà Sistema de frenos Eje K desde 10-2002**

Pos.	Artikelnr.	Bezeichnung	Description	Pièce de rechange	Parte de repuesto	Menge	Ausführung:
25	1000202618	Halterung	Bracket	Équerre	Soporte	1,00	
26	1000222820	Bowdenzug	Bowden cable	Câble de Bowden	Cable Bowden	1,00	
27	1000206479	Halterung	Bracket	Équerre	Soporte	1,00	
28	1000232511	Gabelkopf	Swivel head	Tête à rotule	Cabezal giratorio	1,00	
29	1000225519	Bolzen	Bolt	Boulon	Perno	1,00	
30	1000223284	Scharnier	Hinge	Charnière	Bisagra	1,00	
31	1000222484	Stange	Rod	Tige	Varilla	1,00	
32	1000015384	Stift	Pin	Goupille	Clavija	1,00	
33	1000015342	Schraube	Bolt	Boulon	Perno	2,00	
34	1000015364	Schraube	Bolt	Boulon	Perno	2,00	
35	1000015343	Schraube	Bolt	Boulon	Perno	1,00	
36	1000085385	Schraube	Bolt	Boulon	Perno	1,00	
37	1000085384	Schraube	Bolt	Boulon	Perno	1,00	
38	1000015412	Mutter	Nut	Écrou	Tuerca	1,00	
39	1000015407	Mutter	Nut	Écrou	Tuerca	1,00	
40	1000085588	Mutter	Nut	Écrou	Tuerca	1,00	
41	1000222819	Scheibe	Washer	Rondelle	Disco	1,00	
42	1000082617	Federring	Spring washer	Rondelle de ressort	Arandela de resorte	1,00	
43	1000015406	Mutter	Nut	Écrou	Tuerca	1,00	
44	1000015405	Mutter	Nut	Écrou	Tuerca	1,00	
45	1000015430	Scheibe	Washer	Rondelle	Disco	1,00	
46	1000015432	Scheibe	Washer	Rondelle	Disco	2,00	
47	1000022016	Federring	Spring washer	Rondelle de ressort	Arandela de resorte	2,00	
48	1000095351	Scheibe	Washer	Rondelle	Disco	2,00	
49	1000222726	Schmiernippel	Grease nipple	Raccord graisseur	Boquilla de engrasar	1,00	



**WEIDEMANN**

**Weidemann 1360**

**-195-**

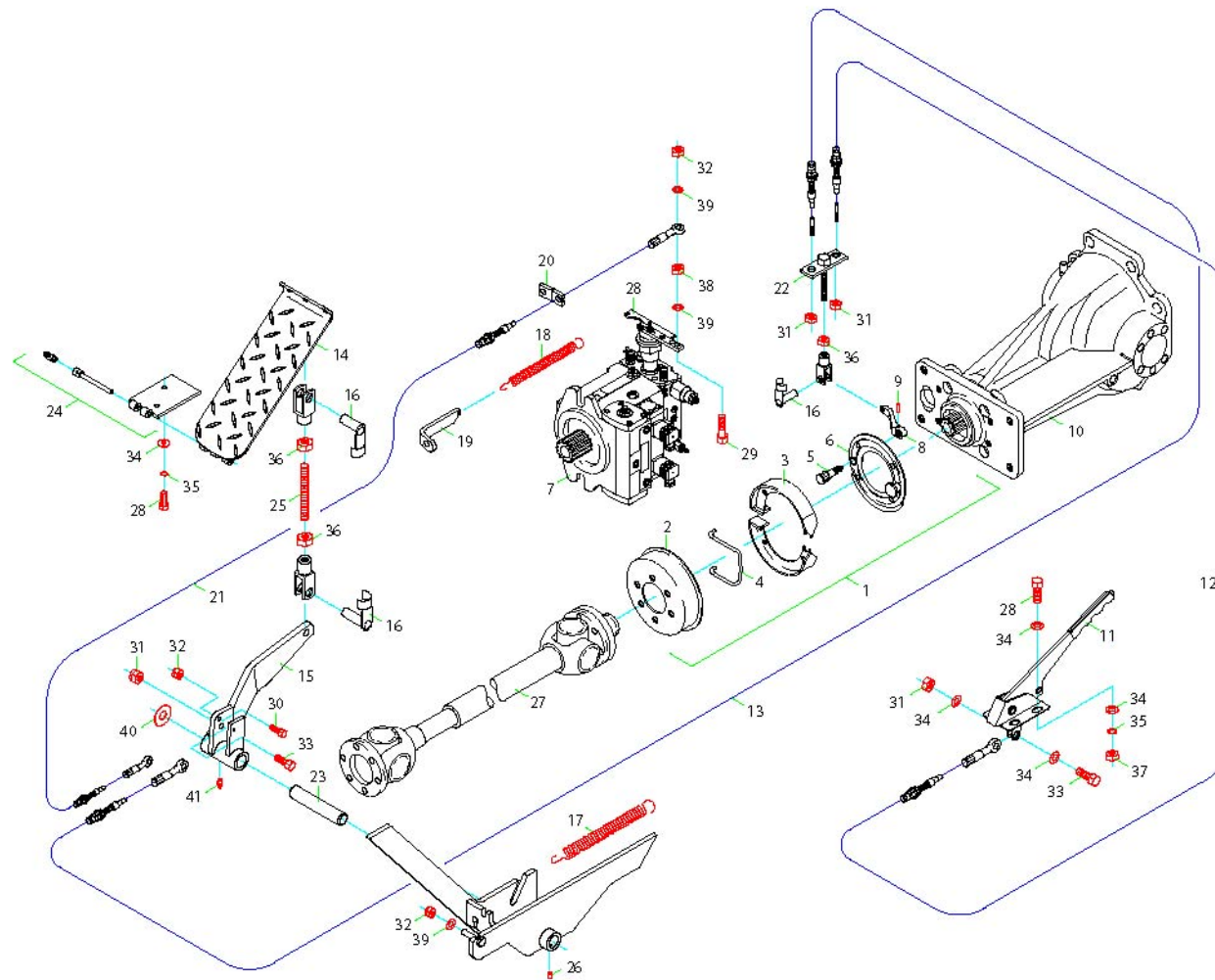

**Bremsanlage S Achse Brake system S Axle Système de freinage essieu S Sistema de frenos Eje S**

Pos.	Artikelnr.	Bezeichnung	Description	Pièce de rechange	Parte de repuesto	Menge	Ausführung:
1	1000196990	Bremse	Brake	Frein	Freno	1,00	b. Bremstrommel
	1000196989	Bremse	Brake	Frein	Freno	1,00	m. Bremstrommel
2	1000196991	Bremstrommel	Brake drum	Tambour de frein	Tambor de freno	1,00	
3	1000196995	Bremsbacken	Brake shoes	Sabots de frein	Pastillas de freno	1,00	
4	1000196993	Feder	Spring	Ressort	Resorte	1,00	
5	1000196996	Bolzen	Bolt	Boulon	Perno	1,00	
6	1000196997	Bremsankerplatte	Brake anchoring plate	Chape de fixation du frein	Placa de anclaje del freno	1,00	
7	1000204448	Ölpumpe	Oil pump	Pompe à huile	Bomba de aceite	1,00	
8	1000196992	Hebel	Lever	Levier	Palanca	1,00	
9	1000196994	Sicherung	Retainer	Dispositif de retenue	Retén	1,00	
10	1000212863	Differential	Differential gear	Engrenage différentiel	Engranaje del diferencial	1,00	
11	1000196803	Hebel	Lever	Levier	Palanca	1,00	
12	1000222753	Bowdenzug	Bowden cable	Câble de Bowden	Cable Bowden	1,00	
13	1000222903	Bowdenzug	Bowden cable	Câble de Bowden	Cable Bowden	1,00	
14	1000205077	Pedal	Pedal	Pédale	Pedal	1,00	
15	1000205071	Hebel	Lever	Levier	Palanca	1,00	
16	1000222571	Gabelkopf	Swivel head	Tête à rotule	Cabezal giratorio	1,00	
17	1000200250	Feder	Spring	Ressort	Resorte	1,00	
18	1000222932	Feder	Spring	Ressort	Resorte	1,00	
19	1000203136	Halterung	Bracket	Équerre	Soporte	1,00	
20	1000202618	Halterung	Bracket	Équerre	Soporte	1,00	
21	1000222820	Bowdenzug	Bowden cable	Câble de Bowden	Cable Bowden	1,00	
22	1000202247	Gabelkopf	Swivel head	Tête à rotule	Cabezal giratorio	1,00	
23	1000225519	Bolzen	Bolt	Boulon	Perno	1,00	

**Bremsanlage S Achse Brake system S Axle Système de freinage essieu S Sistema de frenos Eje S**

Pos.	Artikelnr.	Bezeichnung	Description	Pièce de rechange	Parte de repuesto	Menge	Ausführung:
24	1000223284	Scharnier	Hinge	Charnière	Bisagra	1,00	
25	1000222484	Stange	Rod	Tige	Varilla	1,00	
26	1000015384	Stift	Pin	Goupille	Clavija	1,00	
27	1000226860	Gelenkwelle	Cardan shaft	Arbre à cardan	Eje del cardán	1,00	
28	1000015342	Schraube	Bolt	Boulon	Perno	1,00	
29	1000085385	Schraube	Bolt	Boulon	Perno	1,00	
30	1000085384	Schraube	Bolt	Boulon	Perno	1,00	
31	1000015412	Mutter	Nut	Écrou	Tuerca	1,00	
32	1000085588	Mutter	Nut	Écrou	Tuerca	1,00	
33	1000015343	Schraube	Bolt	Boulon	Perno	1,00	
34	1000222819	Scheibe	Washer	Rondelle	Disco	1,00	
35	1000082617	Federring	Spring washer	Rondelle de ressort	Arandela de resorte	1,00	
36	1000015407	Mutter	Nut	Écrou	Tuerca	1,00	
37	1000015406	Mutter	Nut	Écrou	Tuerca	1,00	
38	1000015405	Mutter	Nut	Écrou	Tuerca	1,00	
39	1000015430	Scheibe	Washer	Rondelle	Disco	1,00	
40	1000095351	Scheibe	Washer	Rondelle	Disco	2,00	
41	1000222726	Schmiernippel	Grease nipple	Raccord graisseur	Boquilla de engrasar	1,00	





**WEIDEMANN**

**Weidemann 1360**

**-199-**

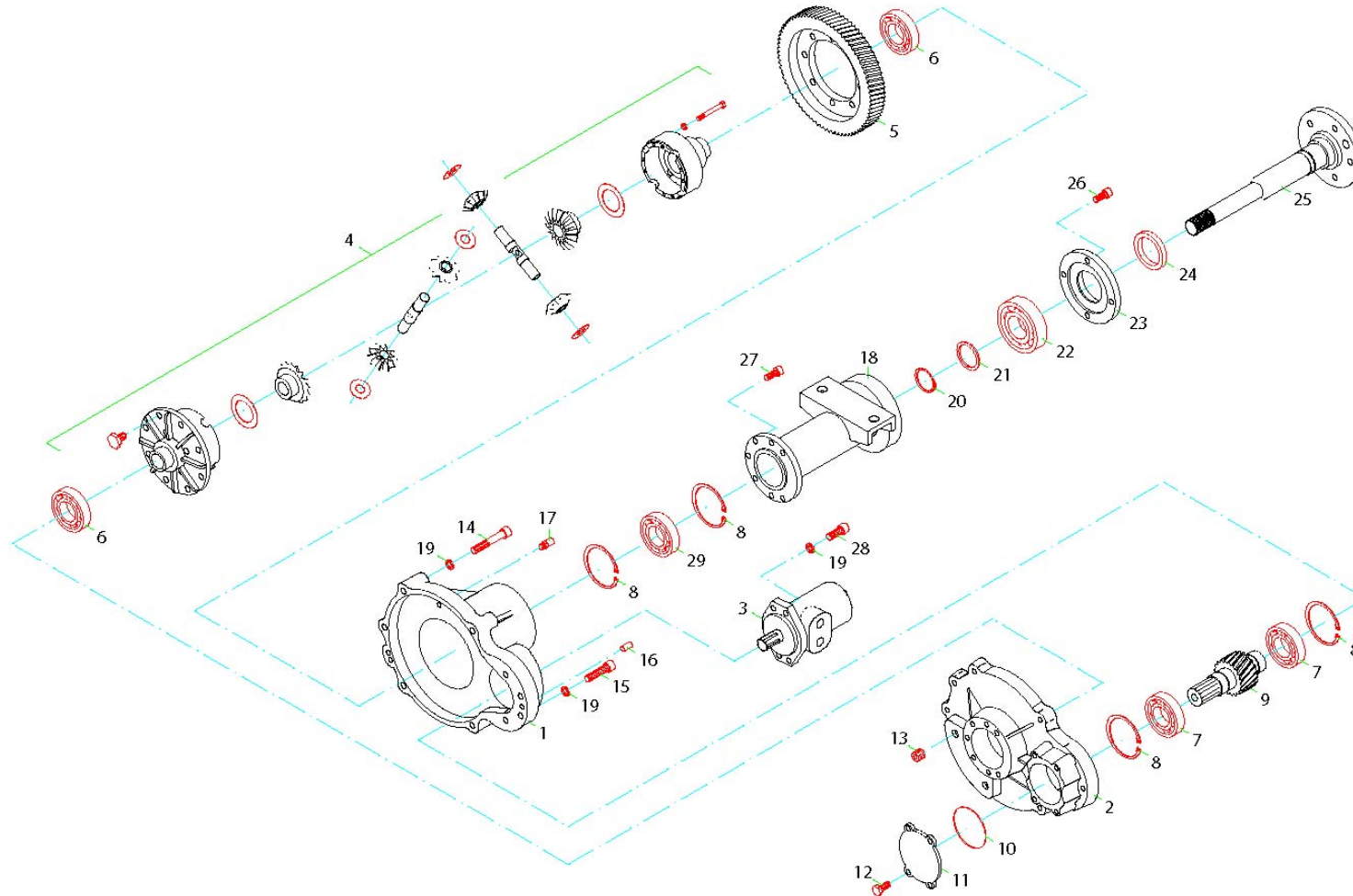



**Vorderachse K90 bis 09.01 Fg.Nr.:10917446 Front axle K90 up to 09-01 Veh.Nr.10917446 Essieu avant K90 jusqu'à 09-01 Veh.Nr.10917446 Eje frontal K90 hasta 09-01 Veh.Nr.10917446**

Pos.	Artikelnr.	Bezeichnung	Description	Pièce de rechange	Parte de repuesto	Menge	Ausführung:
	1000192480	Achse	Axle	Essieu	Eje	1	
	1000192546	Achshälfte	Axle half	Demi essieu	Semieje	1	i.
	1000192548	Achshälfte	Axle half	Demi essieu	Semieje	1	re.
1	1000192597	Gehäuse	Housing	Enveloppe	Carcasa	1	
2	1000192598	Deckel	Cover	Couvercle	Cubierta	1	
3	1000200290	Ölmotor	Hydraulic motor	Moteur hydraulique	Motor hidráulico	1	
	1000225187	Dichtsatz	Service kit	Trousse de service	Kit de servicio	1	
4	1000199033	Differential	Differential gear	Engrenage différentiel	Engranaje del diferencial	1	
5	1000192472	Zahnrad	Gear wheel	Engrenage	Engranaje	1	
6	1000224264	Lager	Bearing	Palier	Cojinete	1	
7	1000225747	Lager	Bearing	Palier	Cojinete	1	
8	1000015474	Ring	Ring	Anneau	Anillo	1	
9	1000193605	Welle	Shaft	Arbre	Árbol	1	
10	1000224983	Dichtung	Gasket	Garniture	Junta de estanqueidad	1	
11	1000192586	Deckel	Cover	Couvercle	Cubierta	1	
12	1000085411	Schraube	Bolt	Boulon	Perno	1	
13	1000222717	Schraube	Bolt	Boulon	Perno	1	
14	1000085479	Schraube	Bolt	Boulon	Perno	1	
15	1000048191	Schraube	Bolt	Boulon	Perno	1	
16	1000223463	Ring	Ring	Anneau	Anillo	1	
17	1000198691	Ventil	Valve	Soupape	Válvula	1	
18	1000202104	Achsrohr	Axle pipe	Tuyau d'essieu	Caño del eje	1	i.
	1000202117	Achsrohr	Axle pipe	Tuyau d'essieu	Caño del eje	1	re.
19	1000022017	Federring	Spring washer	Rondelle de ressort	Arandela de resorte	1	

Vorderachse K90 bis 09.01 Fg.Nr.:10917446 Front axle K90 up to 09-01 Veh.Nr.10917446 Essieu avant K90 jusqu'à 09-01 Veh.Nr.10917446 Eje frontal K90 hasta 09-01 Veh.Nr.10917446

Pos.	Artikelnr.	Bezeichnung	Description	Pièce de rechange	Parte de repuesto	Menge	Ausführung:
20	1000021348	Ring	Ring	Anneau	Anillo	1	
21	1000079454	Scheibe	Washer	Rondelle	Disco	1	
22	1000224987	Lager	Bearing	Palier	Cojinete	1	
23	1000192475	Deckel	Cover	Couvercle	Cubierta	1	
24	1000224899	Wellendichtring	Sealing ring	Bague de scellement	Anillo de sellado	1	
25	4008050446	Welle	Shaft	Arbre	Árbol	1	
26	1000015376	Schraube	Bolt	Boulon	Perno	1	
27	1000223837	Schraube	Bolt	Boulon	Perno	1	
28	1000085475	Schraube	Bolt	Boulon	Perno	1	
29	1000224265	Lager	Bearing	Palier	Cojinete	1	



**WEIDEMANN**

**Weidemann 1360**

**-203-**

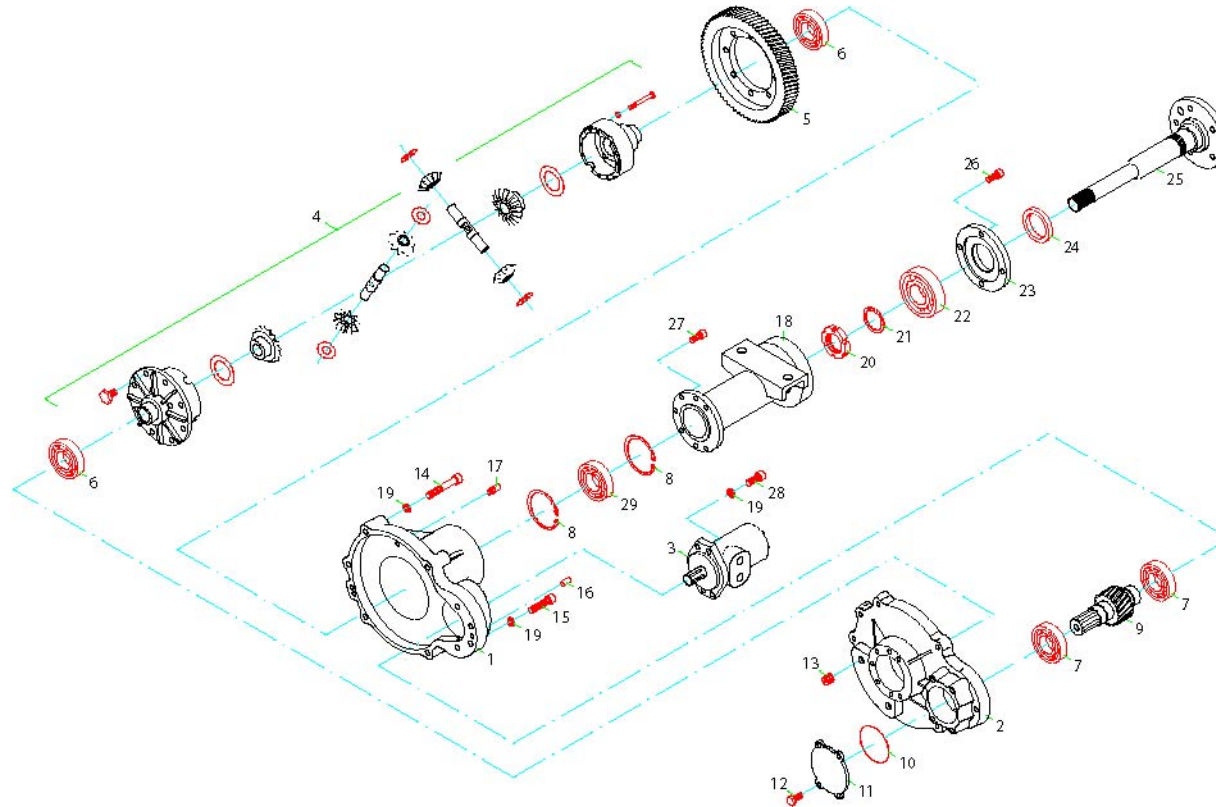

**Vorderachse K90 ab 09.01 Fg.Nr.:10917513 Front axle K90 from 09-01 Veh.Nr.10917513 Essieu avant K90 de 09-01 Veh.Nr.10917513 Eje frontal K90 desde 09-01 Veh.Nr.10917513**

Pos.	Artikelnr.	Bezeichnung	Description	Pièce de rechange	Parte de repuesto	Menge	Ausführung:
	1000203855	Achse	Axle	Essieu	Eje	1,00	
	1000203928	Achshälfte	Axle half	Demi essieu	Semieje	1,00	li.
	1000203929	Achshälfte	Axle half	Demi essieu	Semieje	1,00	re.
1	1000203856	Gehäuse	Housing	Enveloppe	Carcasa	1,00	
2	1000203857	Deckel	Cover	Couvercle	Cubierta	1,00	
3	1000200290	Ölmotor	Hydraulic motor	Moteur hydraulique	Motor hidráulico	1,00	
	1000201718	Ölmotor	Hydraulic motor	Moteur hydraulique	Motor hidráulico	1,00	WÜ
	1000225187	Dichtsatz	Service kit	Trousse de service	Kit de servicio	1,00	
4	1000199033	Differential	Differential gear	Engrenage différentiel	Engranaje del diferencial	1,00	
5	1000192472	Zahnrad	Gear wheel	Engrenage	Engranaje	1,00	
6	1000224264	Lager	Bearing	Palier	Cojinete	2,00	
7	1000003117	Lager	Bearing	Palier	Cojinete	2,00	
8	1000015474	Ring	Ring	Anneau	Anillo	2,00	
9	1000204007	Welle	Shaft	Arbre	Árbol	1,00	
10	1000224983	Dichtung	Gasket	Garniture	Junta de estanqueidad	1,00	
11	1000192586	Deckel	Cover	Couvercle	Cubierta	1,00	
12	1000015345	Schraube	Bolt	Boulon	Perno	4,00	
13	1000222717	Schraube	Bolt	Boulon	Perno	1,00	
14	1000048193	Schraube	Bolt	Boulon	Perno	8,00	
15	1000048193	Schraube	Bolt	Boulon	Perno	8,00	
16	1000223463	Stift	Pin	Goupille	Clavija	1,00	
17	1000198691	Ventil	Valve	Soupape	Válvula	1,00	
18	1000202104	Achsrohr	Axle pipe	Tuyau d'essieu	Caño del eje	1,00	li.
	1000202117	Achsrohr	Axle pipe	Tuyau d'essieu	Caño del eje	1,00	re.

**Vorderachse K90 ab 09.01 Fg.Nr.:10917513 Front axle K90 from 09-01 Veh.Nr.10917513 Essieu avant K90 de 09-01 Veh.Nr.10917513 Eje frontal K90 desde 09-01 Veh.Nr.10917513**

Pos.	Artikelnr.	Bezeichnung	Description	Pièce de rechange	Parte de repuesto	Menge	Ausführung:
19	1000022017	Federring	Spring washer	Rondelle de ressort	Arandela de resorte	4,00	
20	1000222512	Mutter	Nut	Écrou	Tuerca	1,00	
21	1000222590	Scheibe	Washer	Rondelle	Disco	1,00	
22	1000224987	Lager	Bearing	Palier	Cojinete	1,00	
23	1000192475	Deckel	Cover	Couvercle	Cubierta	1,00	
24	1000224899	Wellendichtring	Sealing ring	Bague de scellement	Anillo de sellado	1,00	
25	1000203145	Welle	Shaft	Arbre	Árbol	1,00	
26	1000222555	Schraube	Bolt	Boulon	Perno	4,00	
27	1000222555	Schraube	Bolt	Boulon	Perno	11,00	
28	1000085475	Schraube	Bolt	Boulon	Perno	4,00	
29	1000224265	Lager	Bearing	Palier	Cojinete	1,00	





**WEIDEMANN**

**Weidemann 1360**

**-207-**





Vorderachse S90 Front axle S90 Essieu avant S90 Eje frontal S90

Pos.	Artikelnr.	Bezeichnung	Description	Pièce de rechange	Parte de repuesto	Menge	Ausführung:
	1000212865	Achse	Axle	Essieu	Eje	1,00	
	1000203928	Achshälfte	Axle half	Demi essieu	Semieje	1,00	i.
	1000203929	Achshälfte	Axle half	Demi essieu	Semieje	1,00	re.
1	1000212863	Differential	Differential gear	Engrenage différentiel	Engranaje del diferencial	1,00	
2	1000192600	Deckel	Cover	Couvercle	Cubierta	1,00	
3	1000195004	Gehäuse	Housing	Enveloppe	Carcasa	1,00	
4	1000222717	Schraube	Bolt	Boulon	Perno	1,00	
5	1000198691	Ventil	Valve	Soupape	Válvula	1,00	
6	1000095360	Ring	Ring	Anneau	Anillo	1,00	
7	1000015153	Lager	Bearing	Palier	Cojinete	2,00	
8	1000015474	Ring	Ring	Anneau	Anillo	1,00	
9	1000193692	Flansch	Flange	Bride	Brida	1,00	
10	1000222706	Schraube	Bolt	Boulon	Perno	6,00	
11	1000015412	Mutter	Nut	Écrou	Tuerca	6,00	
12	1000226860	Gelenkwelle	Cardan shaft	Arbre à cardan	Eje del cardán	1,00	
13	1000226764	Reparatursatz	Repair kit	Nécessaire de réparation	Kit de reparaciones	1,00	
14	1000092439	Ring	Ring	Anneau	Anillo	4,00	
15	1000196992	Hebel	Lever	Levier	Palanca	1,00	
16	1000196994	Sicherung	Retainer	Dispositif de retenue	Retén	1,00	
17	1000196997	Bremsankerplatte	Brake anchoring plate	Chape de fixation du frein	Placa de anclaje del freno	1,00	
18	1000015345	Schraube	Bolt	Boulon	Perno	4,00	
19	1000224183	Hülse	Sleeve	Manchon	Manguito	4,00	
20	1000196995	Bremsbacken	Brake shoes	Sabots de frein	Pastillas de freno	1,00	
21	1000196993	Feder	Spring	Ressort	Resorte	1,00	

**Vorderachse S90 Front axle S90 Essieu avant S90 Eje frontal S90**

Pos.	Artikelnr.	Bezeichnung	Description	Pièce de rechange	Parte de repuesto	Menge	Ausführung:
22	1000196991	Bremstrommel	Brake drum	Tambour de frein	Tambor de freno	1,00	
23	1000085473	Schraube	Bolt	Boulon	Perno	1,00	
24	1000225474	Wellendichtring	Sealing ring	Bague de scellement	Anillo de sellado	1,00	
25	1000202117	Achsrohr	Axle pipe	Tuyau d'essieu	Caño del eje	1,00	re.
26	1000202104	Achsrohr	Axle pipe	Tuyau d'essieu	Caño del eje	1,00	ii.
27	1000196996	Bolzen	Bolt	Boulon	Perno	1,00	
28	1000079561	Lager	Bearing	Palier	Cojinete	1,00	
29	1000015470	Ring	Ring	Anneau	Anillo	1,00	
30	1000222512	Mutter	Nut	Écrou	Tuerca	1,00	
31	1000222590	Scheibe	Washer	Rondelle	Disco	1,00	
32	1000224987	Lager	Bearing	Palier	Cojinete	1,00	
33	1000192475	Deckel	Cover	Couvercle	Cubierta	1,00	
34	1000224899	Wellendichtring	Sealing ring	Bague de scellement	Anillo de sellado	1,00	
35	1000203145	Welle	Shaft	Arbre	Árbol	1,00	
36	1000222555	Schraube	Bolt	Boulon	Perno	11,00	
37	1000015354	Schraube	Bolt	Boulon	Perno	1,00	
38	1000015376	Schraube	Bolt	Boulon	Perno	1,00	
39	1000015364	Schraube	Bolt	Boulon	Perno	1,00	
40	1000022016	Federring	Spring washer	Rondelle de ressort	Arandela de resorte	1,00	





**WEIDEMANN**

**Weidemann 1360**

**-211-**

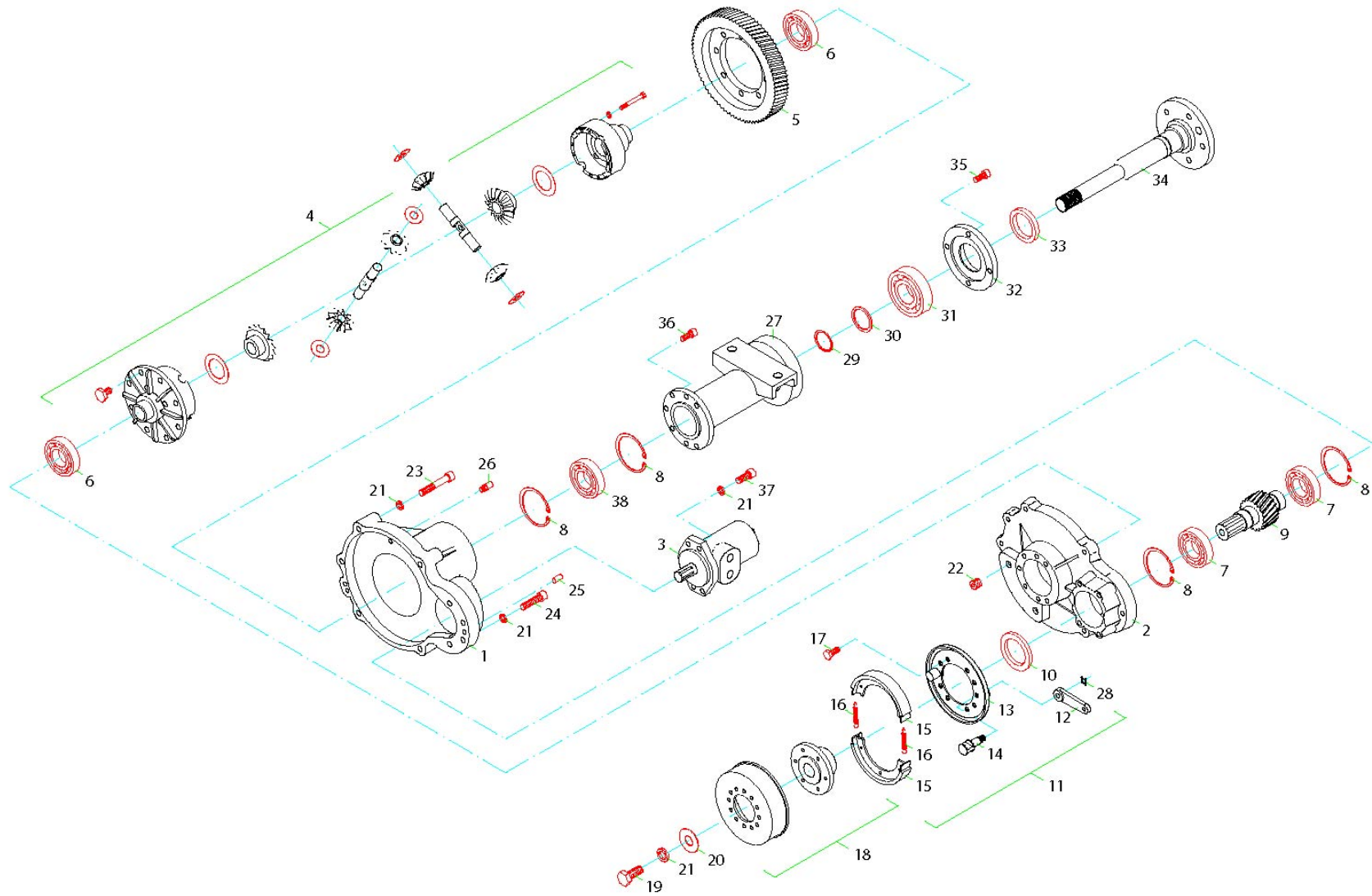

Hinterachse K90 bis 09.01 Fg.Nr.:10917446 Rear axle K90 up to 09-01 Veh.Nr.10917446 Essieu arrière K90 jusqu'à 09-01 Veh.Nr.10917446 Eje trasero K90 hasta 09-01 Veh.Nr.10917446

Pos.	Artikelnr.	Bezeichnung	Description	Pièce de rechange	Parte de repuesto	Menge	Ausführung:
	1000192483	Achse	Axle	Essieu	Eje	1	
	1000192546	Achshälfte	Axle half	Demi essieu	Semieje	1	i.
	1000192548	Achshälfte	Axle half	Demi essieu	Semieje	1	re.
1	1000192597	Gehäuse	Housing	Enveloppe	Carcasa	1	
2	1000192598	Deckel	Cover	Couvercle	Cubierta	1	
3	1000200290	Ölmotor	Hydraulic motor	Moteur hydraulique	Motor hidráulico	1	
	1000201718	Ölmotor	Hydraulic motor	Moteur hydraulique	Motor hidráulico	1	WÜ
	1000225187	Dichtsatz	Service kit	Trousse de service	Kit de servicio	1	
4	1000199033	Differential	Differential gear	Engrenage différentiel	Engranaje del diferencial	1	
5	1000192472	Zahnrad	Gear wheel	Engrenage	Engranaje	1	
6	1000224264	Lager	Bearing	Palier	Cojinete	1	
7	1000225747	Lager	Bearing	Palier	Cojinete	1	
8	1000015474	Ring	Ring	Anneau	Anillo	1	
9	1000193606	Welle	Shaft	Arbre	Árbol	1	
10	1000225477	Wellendichtring	Sealing ring	Bague de scellement	Anillo de sellado	1	
11	1000196973	Bremse	Brake	Frein	Freno	1	
12	1000196975	Hebel	Lever	Levier	Palanca	1	
13	1000196973	Bremsankerplatte	Brake anchoring plate	Chape de fixation du frein	Placa de anclaje del freno	1	
14	1000196978	Bolzen	Bolt	Boulon	Perno	1	
15	1000196977	Bremsbacken	Brake shoes	Sabots de frein	Pastillas de freno	1	
16	1000222939	Feder	Spring	Ressort	Resorte	1	
17	1000085411	Schraube	Bolt	Boulon	Perno	1	
18	1000193645	Bremstrommel	Brake drum	Tambour de frein	Tambor de freno	1	
19	1000015347	Schraube	Bolt	Boulon	Perno	1	

Hinterachse K90 bis 09.01 Fg.Nr.:10917446 Rear axle K90 up to 09-01 Veh.Nr.10917446 Essieu arrière K90 jusqu'à 09-01 Veh.Nr.10917446 Eje trasero K90 hasta 09-01 Veh.Nr.10917446

Pos.	Artikelnr.	Bezeichnung	Description	Pièce de rechange	Parte de repuesto	Menge	Ausführung:
20	1000223005	Scheibe	Washer	Rondelle	Disco	1	
21	1000022017	Federring	Spring washer	Rondelle de ressort	Arandela de resorte	1	
22	1000222717	Schraube	Bolt	Boulon	Perno	1	
23	1000085479	Schraube	Bolt	Boulon	Perno	1	
24	1000048191	Schraube	Bolt	Boulon	Perno	1	
25	1000223463	Ring	Ring	Anneau	Anillo	1	
26	1000198691	Ventil	Valve	Soupape	Válvula	1	
27	1000202104	Achsrohr	Axle pipe	Tuyau d'essieu	Caño del eje	1	i.
	1000202117	Achsrohr	Axle pipe	Tuyau d'essieu	Caño del eje	1	re.
28	1000196976	Sicherung	Retainer	Dispositif de retenue	Retén	1	
29	1000021348	Ring	Ring	Anneau	Anillo	1	
30	1000079454	Scheibe	Washer	Rondelle	Disco	1	
31	1000224987	Lager	Bearing	Palier	Cojinete	1	
32	1000192475	Deckel	Cover	Couvercle	Cubierta	1	
33	1000224899	Wellendichtring	Sealing ring	Bague de scellement	Anillo de sellado	1	
34	4008050446	Welle	Shaft	Arbre	Árbol	1	
35	1000015376	Schraube	Bolt	Boulon	Perno	1	
36	1000223837	Schraube	Bolt	Boulon	Perno	1	
37	1000085475	Schraube	Bolt	Boulon	Perno	1	
38	1000224265	Lager	Bearing	Palier	Cojinete	1	



**WEIDEMANN**

**Weidemann 1360**

**-215-**

Hinterachse K90 ab 09.01 Fg.Nr.:10917513 Rear axle K90 from 09-01 Veh.Nr.10917513 Essieu arrière K90 de 09-01 Veh.Nr.10917513 Eje trasero K90 desde 09-01 Veh.Nr.10917513

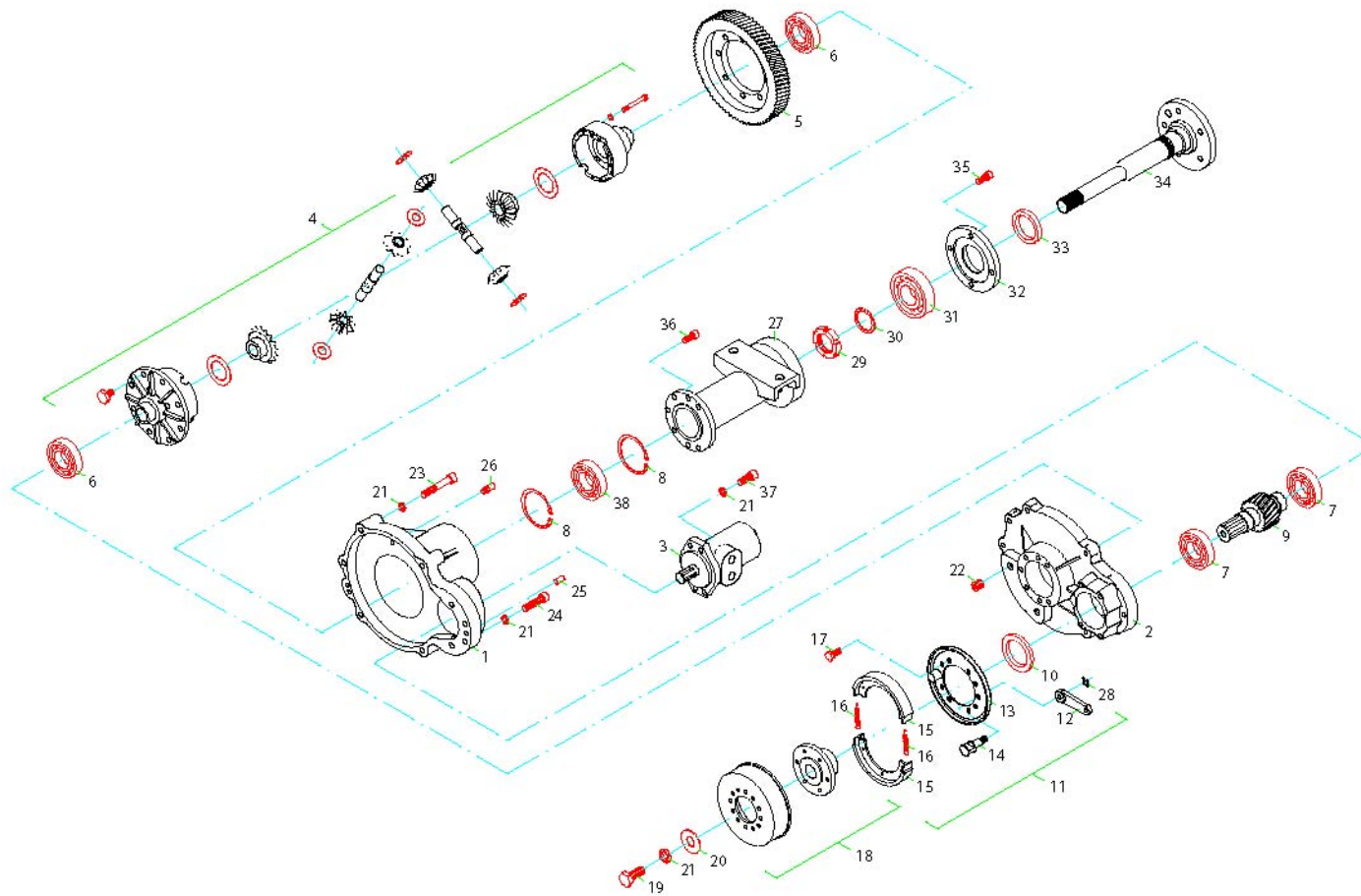



Hinterachse K90 ab 09.01 Fg.Nr.:10917513 Rear axle K90 from 09-01 Veh.Nr.10917513 Essieu arrière K90 de 09-01 Veh.Nr.10917513 Eje trasero K90 desde 09-01 Veh.Nr.10917513

Pos.	Artikelnr.	Bezeichnung	Description	Pièce de rechange	Parte de repuesto	Menge	Ausführung:
	1000203858	Achse	Axle	Essieu	Eje	1,00	
	1000203928	Achshälfte	Axle half	Demi essieu	Semieje	1,00	i.
	1000203929	Achshälfte	Axle half	Demi essieu	Semieje	1,00	re.
1	1000203856	Gehäuse	Housing	Enveloppe	Carcasa	1,00	
2	1000203857	Deckel	Cover	Couvercle	Cubierta	1,00	
3	1000200290	Ölmotor	Hydraulic motor	Moteur hydraulique	Motor hidráulico	1,00	
	1000201718	Ölmotor	Hydraulic motor	Moteur hydraulique	Motor hidráulico	1,00	WÜ
	1000225187	Dichtsatz	Service kit	Trousse de service	Kit de servicio	1,00	
4	1000199033	Differential	Differential gear	Engrenage différentiel	Engranaje del diferencial	1,00	
5	1000192472	Zahnrad	Gear wheel	Engrenage	Engranaje	1,00	
6	1000224264	Lager	Bearing	Palier	Cojinete	1,00	
7	1000003117	Lager	Bearing	Palier	Cojinete	1,00	
8	1000015474	Ring	Ring	Anneau	Anillo	2,00	
9	1000204025	Welle	Shaft	Arbre	Árbol	1,00	
10	1000224983	Dichtung	Gasket	Garniture	Junta de estanqueidad	1,00	
11	1000196973	Bremse	Brake	Frein	Freno	1,00	
12	1000196975	Hebel	Lever	Levier	Palanca	1,00	
13	1000196973	Bremse	Brake	Frein	Freno	1,00	
14	1000196978	Bolzen	Bolt	Boulon	Perno	1,00	
15	1000196977	Bremsbacken	Brake shoes	Sabots de frein	Pastillas de freno	1,00	
16	1000222939	Feder	Spring	Ressort	Resorte	1,00	
17	1000085411	Schraube	Bolt	Boulon	Perno	1,00	
18	1000193645	Bremstrommel	Brake drum	Tambour de frein	Tambor de freno	1,00	
19	1000015347	Schraube	Bolt	Boulon	Perno	1,00	

Hinterachse K90 ab 09.01 Fg.Nr.:10917513 Rear axle K90 from 09-01 Veh.Nr.10917513 Essieu arrière K90 de 09-01 Veh.Nr.10917513 Eje trasero K90 desde 09-01 Veh.Nr.10917513

Pos.	Artikelnr.	Bezeichnung	Description	Pièce de rechange	Parte de repuesto	Menge	Ausführung:
20	1000223005	Scheibe	Washer	Rondelle	Disco	1,00	
21	1000022017	Federring	Spring washer	Rondelle de ressort	Arandela de resorte	1,00	
22	1000222717	Schraube	Bolt	Boulon	Perno	1,00	
23	1000048193	Schraube	Bolt	Boulon	Perno	1,00	
24	1000048193	Schraube	Bolt	Boulon	Perno	1,00	
25	1000223463	Stift	Pin	Goupille	Clavija	1,00	
26	1000198691	Ventil	Valve	Soupape	Válvula	1,00	
27	1000202104	Achsrohr li.	Axle pipe	Tuyau d'essieu	Caño del eje	1,00	li.
	1000202117	Achsrohr re.	Axle pipe	Tuyau d'essieu	Caño del eje	1,00	re.
28	1000196976	Sicherung	Retainer	Dispositif de retenue	Retén	1,00	
29	1000222512	Mutter	Nut	Écrou	Tuerca	1,00	
30	1000222590	Scheibe	Washer	Rondelle	Disco	1,00	
31	1000224987	Lager	Bearing	Palier	Cojinete	1,00	
32	1000192475	Deckel	Cover	Couvercle	Cubierta	1,00	
33	1000224899	Wellendichtring	Sealing ring	Bague de scellement	Anillo de sellado	1,00	
34	1000203145	Welle	Shaft	Arbre	Árbol	1,00	
35	1000222555	Schraube	Bolt	Boulon	Perno	1,00	
36	1000222555	Schraube	Bolt	Boulon	Perno	1,00	
37	1000085475	Schraube	Bolt	Boulon	Perno	1,00	
38	1000224265	Lager	Bearing	Palier	Cojinete	1,00	



**WEIDEMANN**

**Weidemann 1360**

**-219-**

Hinterachse S90 Rear axle S90 Essieu arrière S90 Eje trasero S90

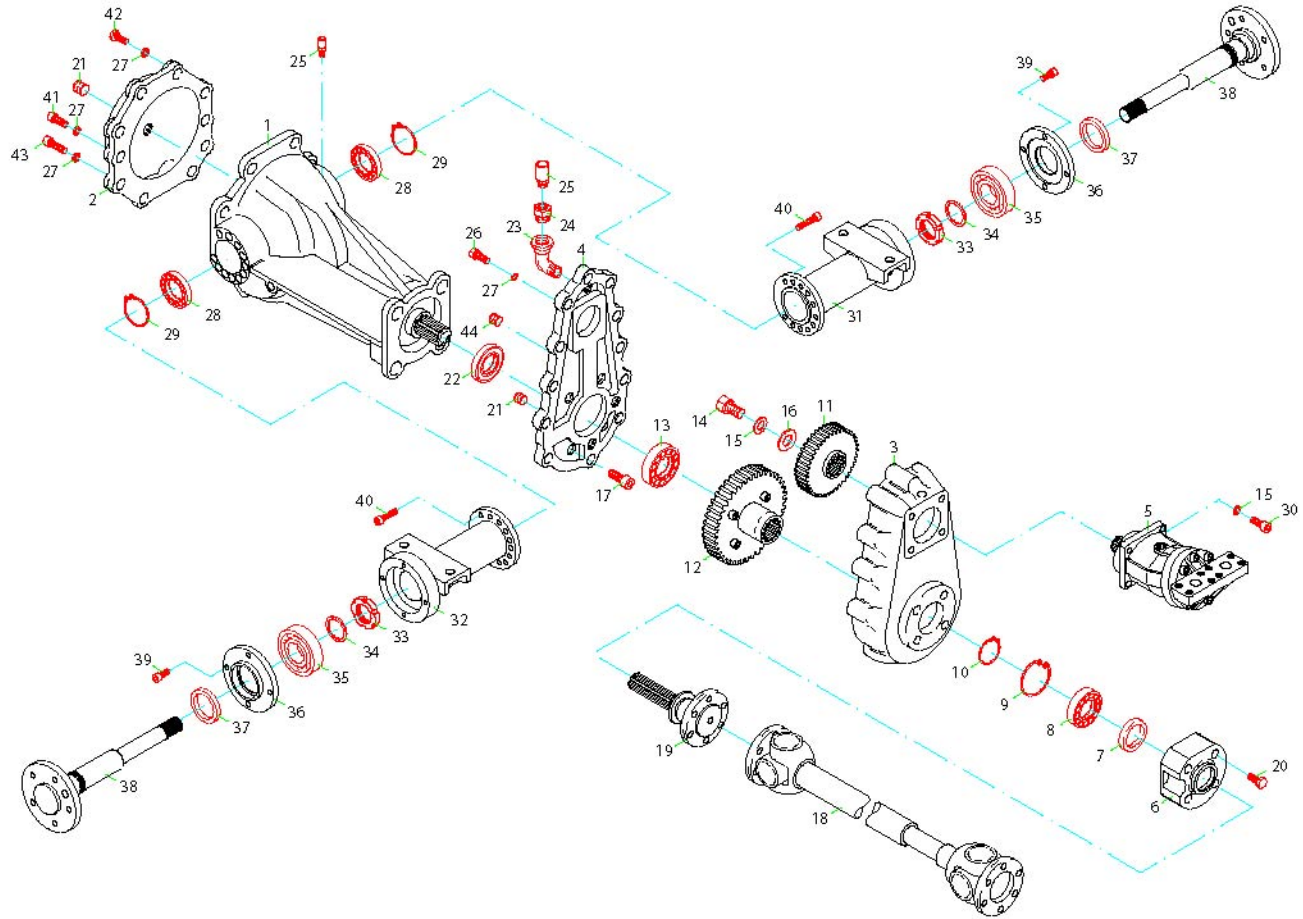

## Hinterachse S90 Rear axle S90 Essieu arrière S90 Eje trasero S90

Pos.	Artikelnr.	Bezeichnung	Description	Pièce de rechange	Parte de repuesto	Menge	Ausführung:
	1000212865	Achse	Axle	Essieu	Eje	1	
	1000203928	Achshälfte	Axle half	Demi essieu	Semieje	1	i.
	1000203929	Achshälfte	Axle half	Demi essieu	Semieje	1	re.
1	1000212863	Differential	Differential gear	Engrenage différentiel	Engranaje del diferencial	1	
2	1000192600	Deckel	Cover	Couvercle	Cubierta	1	
3	1000195176	Gehäuse	Housing	Enveloppe	Carcasa	1	
	1000195119	Getriebe	Gearbox	Boîte de vitesses	Caja de cambios	1	
4	1000195039	Deckel	Cover	Couvercle	Cubierta	1	
5	1000192698	Ölmotor	Hydraulic motor	Moteur hydraulique	Motor hidráulico	1	
6	1000194714	Gehäuse	Housing	Enveloppe	Carcasa	1	
7	1000225017	Wellendichtring	Sealing ring	Bague de scellement	Anillo de sellado	1	
8	1000079561	Lager	Bearing	Palier	Cojinete	1	
9	1000015470	Ring	Ring	Anneau	Anillo	1	
10	1000013030	Ring	Ring	Anneau	Anillo	1	
11	1000193625	Zahnrad	Gear wheel	Engrenage	Engranaje	1	
12	1000193615	Zahnrad	Gear wheel	Engrenage	Engranaje	1	
13	1000003117	Lager	Bearing	Palier	Cojinete	1	
14	1000222553	Schraube	Bolt	Boulon	Perno	1	
15	1000022017	Federring	Spring washer	Rondelle de ressort	Arandela de resorte	1	
16	1000223053	Scheibe	Washer	Rondelle	Disco	1	
17	1000082242	Schraube	Bolt	Boulon	Perno	1	
18	1000226860	Gelenkwelle	Cardan shaft	Arbre à cardan	Eje del cardán	1	
19	1000193702	Flansch	Flange	Bride	Brida	1	
20	1000047783	Schraube	Bolt	Boulon	Perno	1	
21	1000222717	Schraube	Bolt	Boulon	Perno	1	



## Hinterachse S90 Rear axle S90 Essieu arrière S90 Eje trasero S90

Pos.	Artikelnr.	Bezeichnung	Description	Pièce de rechange	Parte de repuesto	Menge	Ausführung:
22	1000225474	Wellendichtring	Sealing ring	Bague de scellement	Anillo de sellado	1	
23	1000225926	Verschraubung	Screw coupling	Couplage fileté	Acoplamiento roscado	1	
24	1000223206	Schraube	Bolt	Boulon	Perno	1	
25	1000198691	Ventil	Valve	Soupape	Válvula	1	
26	1000015346	Schraube	Bolt	Boulon	Perno	1	
27	1000022016	Federring	Spring washer	Rondelle de ressort	Arandela de resorte	1	
28	1000079561	Lager	Bearing	Palier	Cojinete	1	
29	1000015470	Ring	Ring	Anneau	Anillo	1	
30	1000085419	Schraube	Bolt	Boulon	Perno	1	
31	1000202117	Achsrohr	Axle pipe	Tuyau d'essieu	Caño del eje	1	re.
32	1000202104	Achsrohr	Axle pipe	Tuyau d'essieu	Caño del eje	1	li.
33	1000222512	Mutter	Nut	Écrou	Tuerca	1	
34	1000079454	Scheibe	Washer	Rondelle	Disco	1	
35	1000224987	Lager	Bearing	Palier	Cojinete	1	
36	1000192475	Deckel	Cover	Couvercle	Cubierta	1	
37	1000224899	Wellendichtring	Sealing ring	Bague de scellement	Anillo de sellado	1	
38	1000203145	Welle	Shaft	Arbre	Árbol	1	
39	1000222555	Schraube	Bolt	Boulon	Perno	1	
40	1000015376	Schraube	Bolt	Boulon	Perno	1	
41	1000015354	Schraube	Bolt	Boulon	Perno	1	
42	1000015364	Schraube	Bolt	Boulon	Perno	1	
43	1000015354	Schraube	Bolt	Boulon	Perno	1	
44	1000222717	Schraube	Bolt	Boulon	Perno	1	



**WEIDEMANN**

**Weidemann 1360**

**-223-**

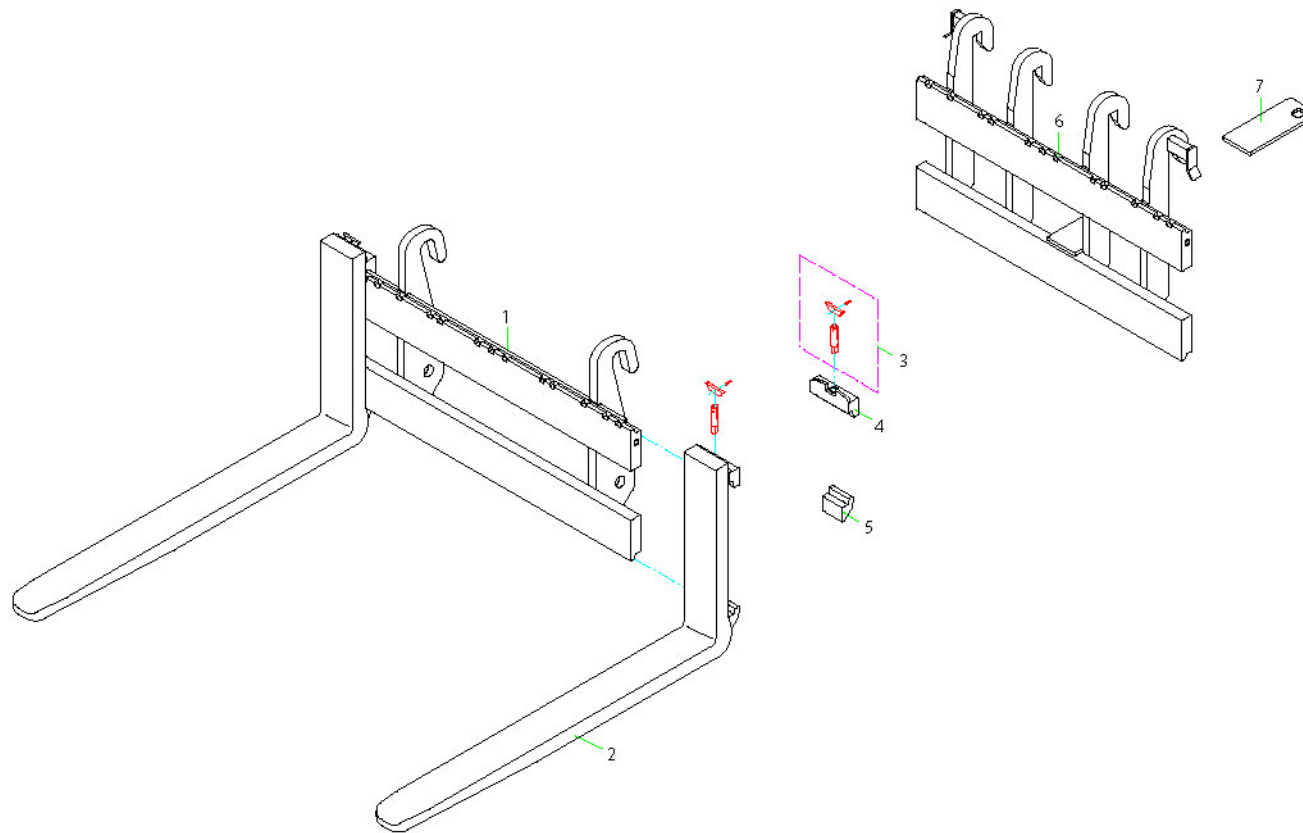



**Palettengabel Pallet fork Fourche à palette Horquilla para paletas**

Pos.	Artikelnr.	Bezeichnung	Description	Pièce de rechange	Parte de repuesto	Menge	Ausführung:
	1000228196	Palettengabeln 1000 HT/MV	Pallet forks 1000 HT/MV	Fourches à palette 1000 HT/MV	Horquilla para paletas 1000 HT/MV	1	HT/MV
	1000228151	Palettengabel 1000 HT/HV	Pallet fork 1000 HT/HV	Fourche à palette 1000 HT/HV	Horquilla para paletas 1000 HT/HV	1	HT/HV
1	1000228149	Aufnahmebock HV	Adapter plate HV	Plaque d'adaptateur HV	Placa del adaptador HV	1	
2	1000226876	Zinken	Tine	Dent	Diente	2	
3	1000030560	Arretierungsstift	Locking pin	Goupille de verrouillage	Clavija de bloqueo	1	
4	1000196745	Haken	Hook	Crochet	Gancho	1	
5	1000196747	Haken	Hook	Crochet	Gancho	1	
6	1000228172	Aufnahmebock MV	Adapter plate MV	Plaque d'adaptateur MV	Placa del adaptador MV	1	
7	1000200865	Lasche	Strap	Sangle	Banda	1	



Erdschaufel Earth shovel Pelle à terre Pala de tractor

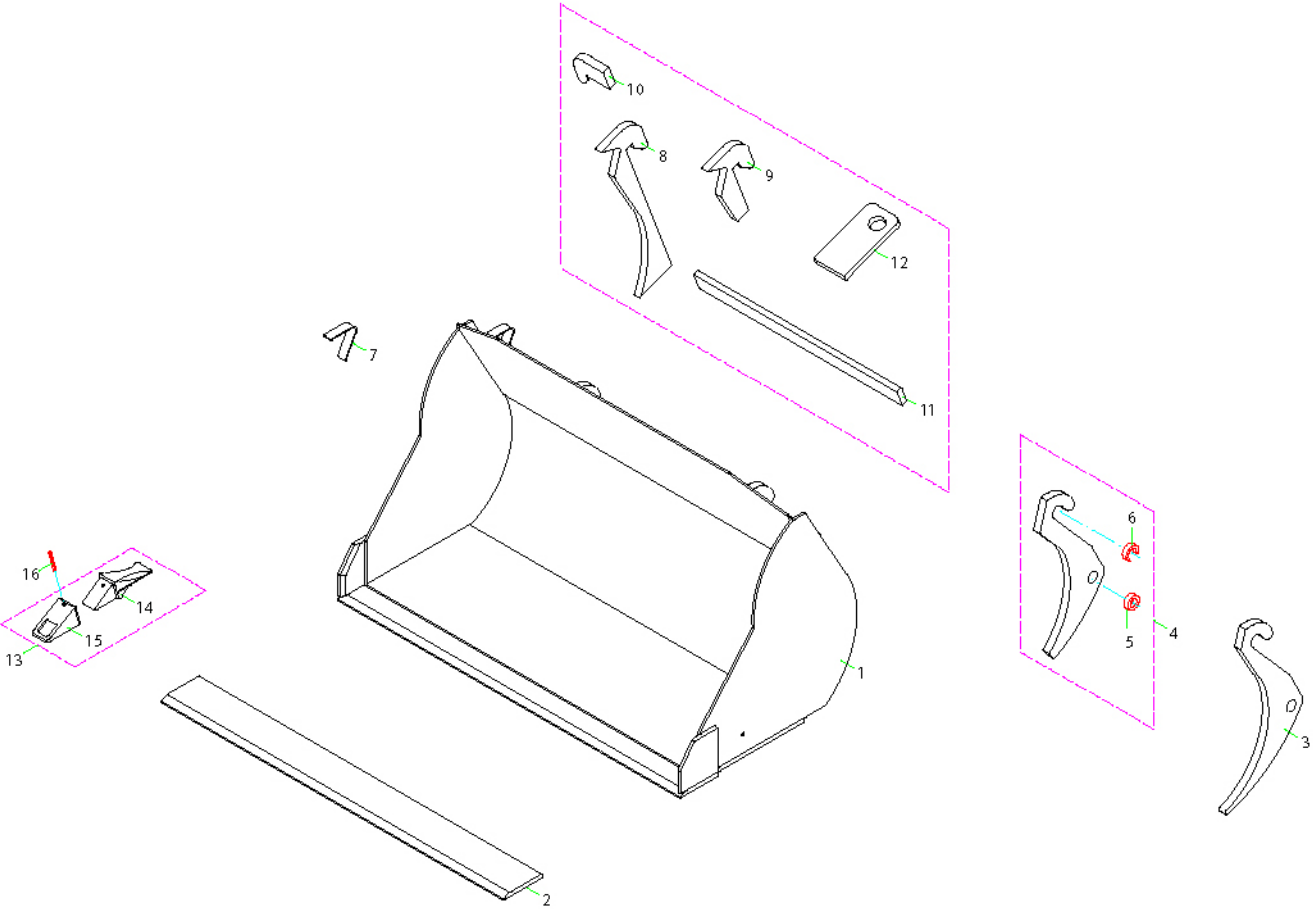

**Erdschaufel Earth shovel Pelle à terre Pala de tractor**

Pos.	Artikelnr.	Bezeichnung	Description	Pièce de rechange	Parte de repuesto	Menge	Ausführung:
1	1000226998	Erdschaufel 1150 RZ HT/MV	Earth shovel 1150 RZ HT/MV	Pelle à terre 1150 RZ HT/MV	Pala de tractor 1150 RZ HT/MV	1	HT/MV
	1000228126	Erdschaufel 980 RZ HT/MV	Earth shovel 980 RZ HT/MV	Pelle à terre 980 RZ HT/MV	Pala de tractor 980 RZ HT/MV	1	HT/MV
	1000228127	Erdschaufel 980 RZ HT/HV	Earth shovel 980 RZ HT/HV	Pelle à terre 980 RZ HT/HV	Pala de tractor 980 RZ HT/HV	1	HT/HV
	1000227014	Erdschaufel 1150 HT/HV	Earth shovel 1150 HT/HV	Pelle à terre 1150 HT/HV	Pala de tractor 1150 HT/HV	1	HT/HV
2	1000199274	Schürfkante	Scraper slab	Racloir de dalle	Superficie de raspadora	1	
	1000199280	Schürfkante	Scraper slab	Racloir de dalle	Superficie de raspadora	1	
3	1000200911	Haken	Hook	Crochet	Gancho	1	
4	1000200910	Haken	Hook	Crochet	Gancho	1	
5	1000224785	Buchse	Bushing	Garniture	Manguito	1	
6	1000224789	Buchse	Bushing	Garniture	Manguito	1	
7	1000195910	Stahl	Steel	Acier	Acero	1	
8	1000200895	Haken	Hook	Crochet	Gancho	1	
9	1000200896	Haken	Hook	Crochet	Gancho	1	
10	1000200897	Haken	Hook	Crochet	Gancho	1	
11	1000200909	Haken	Hook	Crochet	Gancho		
12	1000200865	Lasche	Strap	Sangle	Banda	1	
13	1000199309	Reißzahn	Ripping tooth	Dent couchée	Diente escarificador	1	
14	1000199310	Halter	Bracket	Équerre	Soporte	1	
15	1000199312	Spitze	Tip	Pointe	Punta	1	
16	1000085652	Hülse	Sleeve	Manchon	Manguito	1	
16	1000085646	Hülse	Sleeve	Manchon	Manguito	1	



## Krokodilgebiss Crocodile teeth Dents crocodile Pinzas de cocodrilo

Pos.	Artikelnr.	Bezeichnung	Description	Pièce de rechange	Parte de repuesto	Menge	Ausführung:
	1000228306	Krokodilgebiß 930 MV	Crocodile teeth 930 MV	Dents crocodile 930 MV	Pinzas de cocodrilo 930 MV	1	930 MV
	1000228304	Krokodilgebiß 930 HV	Crocodile teeth 930 HV	Dents crocodile 930 HV	Pinzas de cocodrilo 930 HV	1	930 HV
1	1000192392	Krokodilgebiß 930 MV	Crocodile teeth MV	Dents crocodile MV	Pinzas de cocodrilo MV	1	930 MV
	1000192400	Krokodilgebiß 930 HT/HV	Crocodile teeth 930 HT/HV	Dents crocodile 930 HT/HV	Pinzas de cocodrilo 930 HT/HV	1	930 HV
2	1000200833	Zinkenbalken	Tine beam	Poutre porte-dents	Travesaño dentado	1	
3	1000194570	Buchse	Bushing	Garniture	Manguito	1	
4	1000200817	Haken	Hook	Crochet	Gancho	1	
5	1000200823	Lasche	Strap	Sangle	Banda	1	
6	1000200827	Lasche	Strap	Sangle	Banda	1	
7	1000192434	Krokodilgebißoberteil	Crocodile teeth upper part	Dents crocodile partie supérieure	Pinzas de cocodrilo parte superior	1	
	1000192433	Krokodilgebißoberteil	Crocodile teeth upper part	Dents crocodile partie supérieure	Pinzas de cocodrilo parte superior	1	
8	1000200825	Lasche	Strap	Sangle	Banda	1	
9	1000200837	Zinken	Tine	Dent	Diente	5	
10	1000224771	Buchse	Bushing	Garniture	Manguito	1	
11	1000194572	Zinken	Tine	Dent	Diente	4	
12	1000222471	Mutter	Nut	Écrou	Tuerca	4	
13	1000223953	Schraube	Bolt	Boulon	Perno	1	
14	1000174642	Mutter	Nut	Écrou	Tuerca	1	
15	1000223919	Schraube	Bolt	Boulon	Perno	1	
16	1000015440	Scheibe	Washer	Rondelle	Disco	1	
17	1000018412	Mutter	Nut	Écrou	Tuerca	1	
18	1000223913	Schraube	Bolt	Boulon	Perno	1	

## Krokodilgebiss Crocodile teeth Dents crocodile Pinzas de cocodrilo

Pos.	Artikelnr.	Bezeichnung	Description	Pièce de rechange	Parte de repuesto	Menge	Ausführung:
19	100018412	Mutter	Nut	Écrou	Tuerca	1	
20	1000222726	Schmiernippel	Grease nipple	Raccord graisseur	Boquilla de engrasar	1	
21	1000230019	Zylinder	Cylinder	Cylindre	Cilindro	1	3483 934 M
	1000230249	Zylinder	Cylinder	Cylindre	Cilindro	1	3483 934 M WÜ
	1000225115	Dichtsatz	Service kit	Trousse de service	Kit de servicio	1	
	1000230019	Zylinder	Cylinder	Cylindre	Cilindro	1	3483 934 HP
	1000230293	Zylinder	Cylinder	Cylindre	Cilindro	1	3483 934 HP WÜ
	1000225114	Dichtsatz	Service kit	Trousse de service	Kit de servicio	1	
22	1000225909	Verschraubung	Screw coupling	Couplage fileté	Acoplamiento roscado	1	
23	1000019582	Platte	Plate	Plaque	Placa	1	
24	1000222581	Klemmbackenpaar	Clamping block	Cale	Bloque de sujeción	1	
25	1000085457	Schraube	Bolt	Boulon	Perno	1	
26	1000217483	Schlauch	Hose	Boyau	Manguera	1	
27	1000226204	Kupplung	Coupling	Couplage	Acoplamiento	1	
28	1000226073	Deckel	Cover	Couvercle	Cubierta	1	
29	1000195063	Lasche	Strap	Sangle	Banda	1	
30	1000195059	Lasche	Strap	Sangle	Banda	1	
31	1000203471	Verstärkung	Reinforcement	Renforcement	Refuerzo	1	
32	1000195061	Eisen	Steel	Acier	Acero	1	